



Steam Trap

UNA 23

UNA 25

UNA 26

UNA 27h

valvesgo.com

EN
English

Original Installation Instructions
810516-10

valvesgo.com

Important Notes

Usage for the intended purpose	4
Safety notes	4
Danger	4
Attention	4
Application of European Directives	5
Notes on the Declaration of Conformity/Manufacturer's Declaration	5

Explanatory Notes

Scope of supply	6
Description	6
Function	7
Design	7

Technical Data

UNA 23h/v, UNA 25h/v, UNA 26h/v, UNA 27h	8
Pressure/temperature ratings	9
Rating plate/markings	9

Components

Component parts of UNA 23h, UNA 25h, UNA 26h	10
Component parts of UNA 23v, UNA 25v, UNA 26v, UNA 23h/v (sightglass)	11
Component parts of UNA 23h max, UNA 25h max, UNA 26h max	12
Component parts of UNA 23v max, UNA 25v max, UNA 26v max	13
Component parts of UNA 27h	14
Key to component parts	15

Installation

UNA 23h/v, UNA 25h/v, UNA 26h/v, UNA 27h	16
Danger	16
Flanged version	16
Screwed end version	16
Socket-weld version	17
Butt-weld version	17
Attention	17
Heat treatment of welds	17
Manual vent valve	18
Tools	18
Float lifting lever (optional extra)	18

Bringing into Service

UNA 23h/v, UNA 25h/v, UNA 26h/v, UNA 27h.....	19
Danger	19

Operation

Manual vent valve	19
Float lifting lever	19

Maintenance

UNA 23h/v, UNA 25h/v, UNA 26h/v, UNA 27h.....	20
Danger	20
Checking the steam trap	20
Cleaning/replacing the control unit	20
Replacing the air venting unit (DUPLEX-MAX control unit)	21
Tools	21
Cleaning/replacing the sightglass.....	22
Attention	22
Torques	23

Spare Parts

Spare parts list for UNA 23h/v, UNA 25h/v, UNA 26h/v	24
Spare parts list for UNA 26h stainless steel	26
Spare parts list for UNA 27h	28

Taking out of Service

Danger	29
Attention	29
Disposal	29

Important Notes

Usage for the intended purpose

UNA 23, UNA 25

Use the steam traps only for discharging condensate from steam. Use in pipes for removing condensate from steam, paying attention to the admissible pressure and temperature ratings and the impact of chemicals and corrosion on the pressure equipment.

UNA 26, UNA 26h stainless steel, UNA 27h

Use the steam traps for discharging condensate and fluids only. Use in pipes for removing condensate from steam and other condensing gases, paying attention to the admissible pressure and temperature ratings and the impact of chemicals and corrosion on the pressure equipment.

Safety Note

The equipment may only be installed, brought into service, maintained and refitted by authorised staff who have the required knowledge and have undergone specific training.

Danger



The equipment is under pressure and hot during operation. Risk of injuries and severe burns to the entire body.

Only perform installation and maintenance work when the equipment is not under pressure (0 bar) and is cold (20 °C).

Before performing installation or maintenance work, vent the equipment and isolate it from both upstream and downstream pressure.

Sharp edges on inner parts present a danger of cuts to hands.

Always wear industrial gloves when working on the equipment.

Attention



The rating plate specifies the technical features of the equipment.

Do not bring into service or operate any equipment that does not bear its own specific rating plate. The pressure and temperature data on the trap's rating plate must conform to the requirements of the system.

Application of European Directives

Pressure Equipment Directive

The equipment conforms to this directive (see "Manufacturer's Declaration" section) and can be used for the following fluids:

UNA 23 and UNA 25

- Group 2 fluids

UNA26, UNA 26h stainless steel and UNA 27h

- Group 1 fluids
- Group 2 fluids

ATEX Directive

The equipment does not have a potential ignition source and as such is not subject to this directive (see "Manufacturer's Declaration" section).

Once installed, static electricity may arise between the equipment and the connected system. During use in potentially explosive atmospheres, the discharge or prevention of possible electrostatic charging is the responsibility of the manufacturer or owner of the system.

If there is a possibility of fluid escaping, e.g. via actuating devices or leaks in screwed couplings, the manufacturer or owner of the system must take this into consideration when dividing the area into zones.

Notes on the Declaration of Conformity/ Manufacturer's Declaration

You can find details on the conformity assessment in accordance with European Directives in our Declaration of Conformity or Manufacturer's Declaration.

You can request the valid Declaration of Conformity or Manufacturer's Declaration from the address below:

GESTRA AG

Münchener Strasse 77

28215 Bremen

Germany

Tel. +49 421 3503-0

Fax +49 421 3503-393

E-mail info@de.gestra.com

Web www.gestra.com

Modifications to the equipment not approved by us will cause this Declaration to lose its validity.

Scope of supply

UNA 2.. with SIMPLEX / SIMPLEX-MAX control unit

- 1 steam trap UNA 2..
- 1 manual vent valve with sealing ring (supplied but not fitted)
- 1 float lifting lever (optional extra)
- 1 Installation & Operating Manual

UNA 2.. with DUPLEX/DUPLEX-MAX control unit

- 1 steam trap UNA 2..
- 1 manual vent valve with sealing ring (optional extra)
- 1 float lifting lever (optional extra)
- 1 Installation & Operating Manual

Description

UNA 2... are ball float traps with a rolling ball regulator (SIMPLEX/DUPLEX control unit) or bellows regulator (SIMPLEX-/DUPLEX-MAX control unit). As their operation is not dependent on back pressure, these steam traps are suitable for universal use.

UNA 2... steam traps consist of a body with flange-mounted cover or lid, and a control unit. Functional parts can be replaced by taking off the cover, with no need to remove the trap body from the pipe. Different control units are available for the steam traps.

The SIMPLEX model is a float-actuated, level-based control unit that is especially suitable for cold condensate and superheated steam. The DUPLEX model is a float-actuated control unit with automatic, temperature-based venting for saturated steam systems.

The SIMPLEX-MAX model is a float-actuated, level-based control unit for large condensate flowrates, and is particularly suitable for cold condensate and superheated steam. The DUPLEX-MAX model is a float-actuated control unit for large condensate flowrates with automatic, temperature-based venting for saturated steam systems.

UNA 2...h for installation in horizontal pipes.

UNA 2...v for installation in vertical pipes.

The UNA 23h/v steam trap is also available with integrated glass water-level gauge (sightglass).

Function

The ball valve of the control unit is continuously opened by the float as a function of the condensate level in the trap. When the valve is fully open, the cross-sectional area (CSA) of the orifice dictates the maximum flowrate. The maximum admissible differential pressure of the control unit depends on the CSA of the orifice, the density of the fluid being discharged and the pressure/temperature ratings of the trap body. Different orifices are available, and they can also be exchanged subsequently.

Float traps equipped with DUPLEX or DUPLEX-MAX control units are capable of venting a saturated steam system during both start-up and operation.

Design

UNA 23h, UNA 25h, UNA 26h, UNA 26h stainless steel, UNA 27h:

Version for installation in horizontal pipes

UNA 23v, UNA 25v, UNA 26v:

Version for installation in vertical pipes

UNA 23h, UNA 23v:

Version with sightglass (integrated glass water-level gauge)

Technical Data

UNA 23h/v, UNA 25h/v, UNA 26h/v, UNA 27h

Orifices (seat design)	Maximum admissible differential pressure ΔPMX ¹⁾²⁾		UNA 23h/v	UNA 25h/v UNA 26h/v UNA 26h stainless steel	UNA 27h
	[bar]	[psi]			
Orifice 2	2	29.0	●	●	
Orifice 4	4	58.0	●	●	
Orifice 4 MAX	4	58.0	●	●	
Orifice 8	8	116.0	●	●	
Orifice 8 MAX	8	116.0	●	●	
Orifice 13	13	188.5	●	●	
Orifice 13 MAX	13	188.5	●	●	
Orifice 16	16	232.0			●
Orifice 22	22	319.1		●	
Orifice 22 MAX	22	319.1		●	
Orifice 28	28	406.1			●
Orifice 32	32	464.1		●	
Orifice 32 MAX	32	464.1		●	
Orifice 45	45	652.6			●

Pressure/temperature ratings

UNA 2... without sightglass:

For pressure/temperature ratings, see the marking on the body or the information on the rating plate: Pressure class PN/Class, material number, maximum temperature, maximum pressure, maximum differential pressure.

UNA 23h/v: Maximum admissible temperature: 300°C

UNA 25h/v: Maximum admissible temperature: 350°C

UNA 26h stainless steel: Maximum admissible temperature: 300°C

UNA 26h/v: Maximum admissible temperature: 400°C

UNA 23h/v with sightglass: Maximum admissible temperature: 240°C

Reduced temperature limits for sightglass with integrated glass water-level gauge. If the pH value is above 9.0 and the fluid temperature exceeds 200°C, the glass will get more wear.

Rating plate/markings

For pressure and temperature ratings and type of orifice, see the information on the rating plate or body.

The type and version are indicated on the rating plate or body:

- Manufacturer's name/logo
- Type designation
- Pressure class PN or Class
- Material number
- Stamp on trap body, e.g. $\frac{4}{08}$ indicates the quarter and year of manufacture (example: 4th quarter of 2008).

Components

Component parts of UNA 23h, UNA 25h, UNA 26h

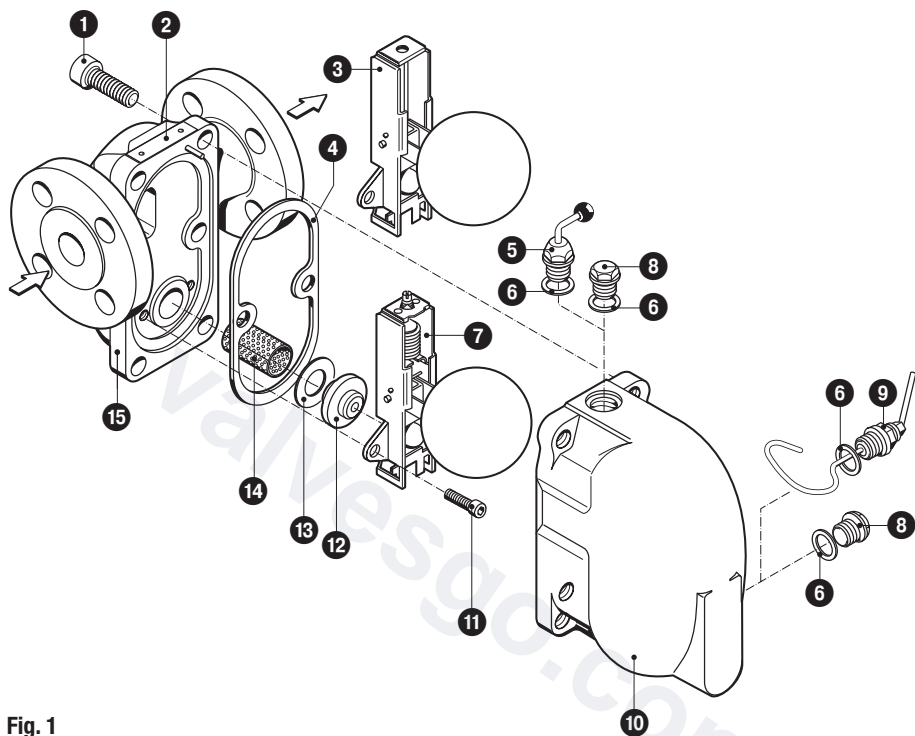

Fig. 1

Component parts of UNA 23v, UNA 25v, UNA 26v, UNA 23h/v (sightglass)

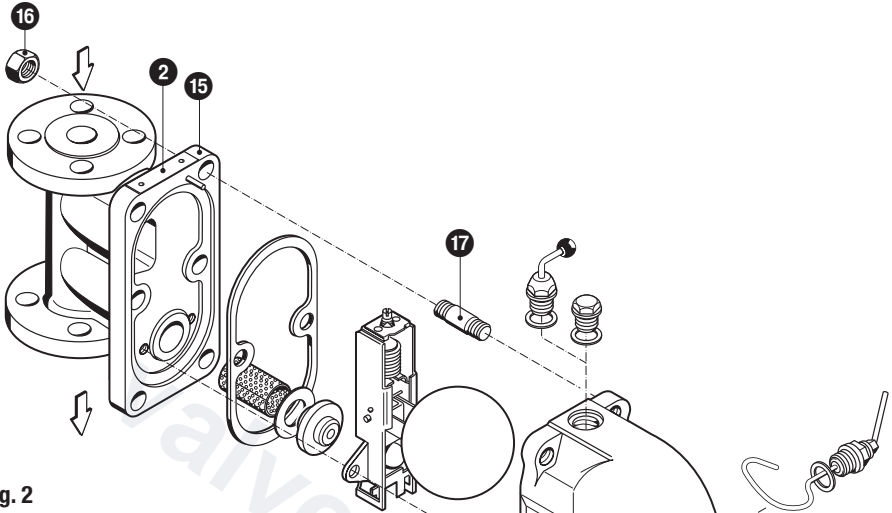

Fig. 2

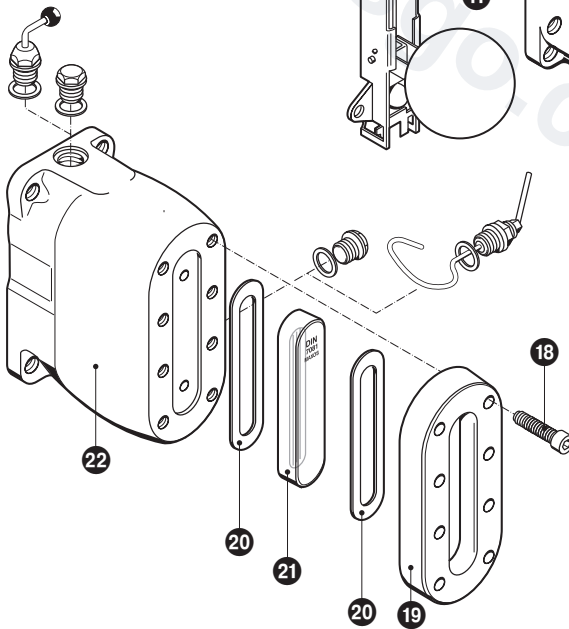

Fig. 3

Component parts of UNA 23h max, UNA 25h max, UNA 26h max

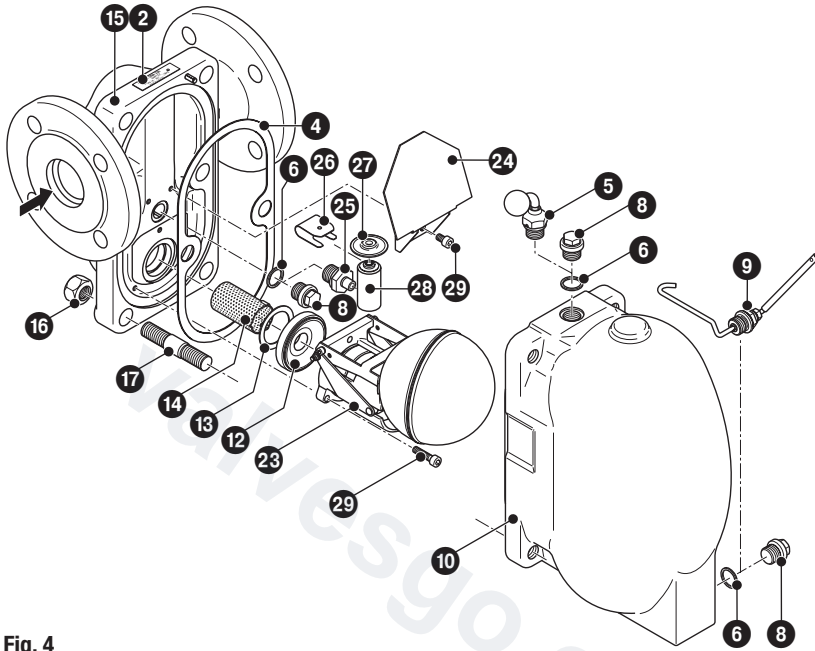

Fig. 4

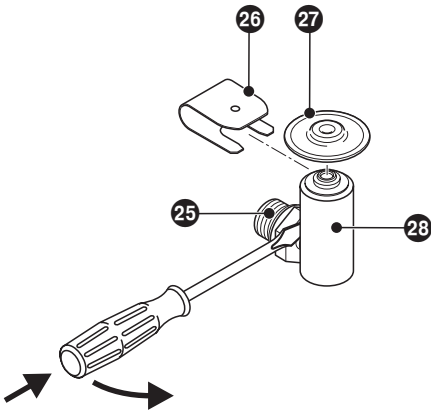

Fig. 5

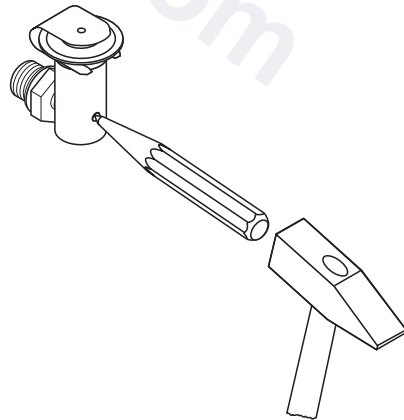

Fig. 6

Component parts of UNA 23v max, UNA 25v max, UNA 26v max

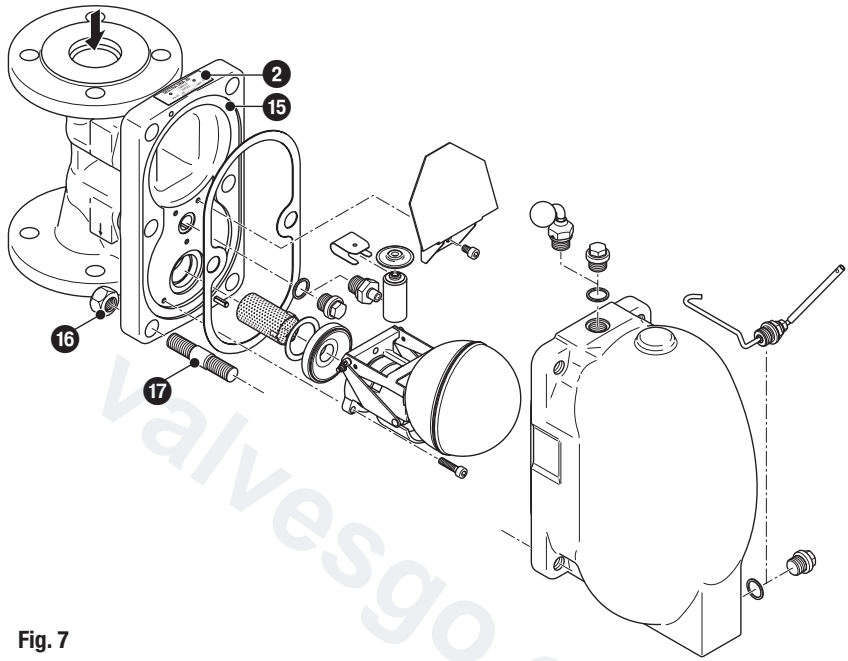

Fig. 7

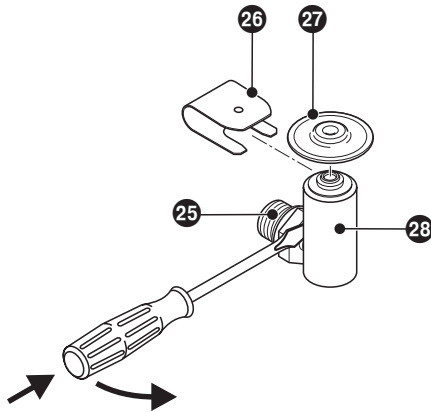

Fig. 5

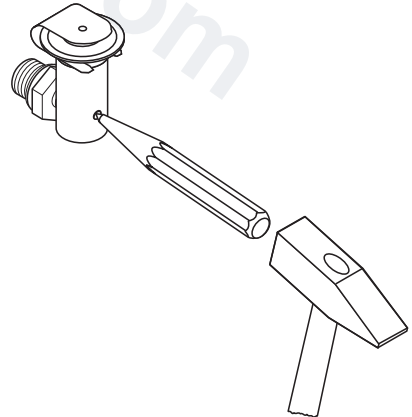

Fig. 6

Component parts of UNA 27h

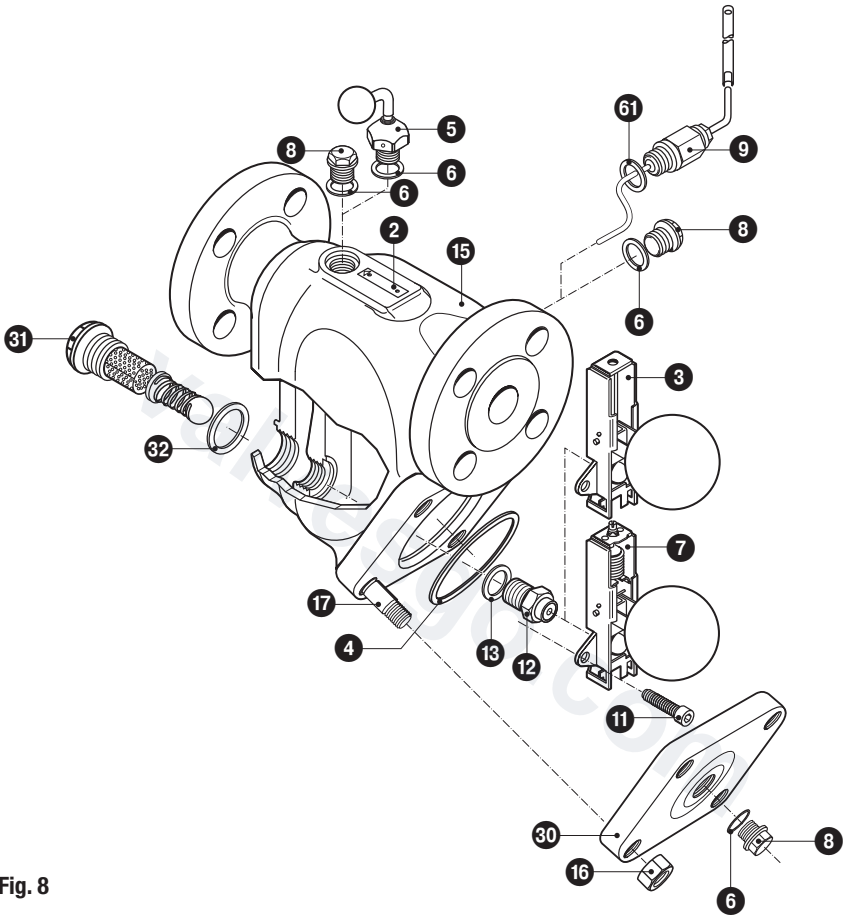

Fig. 8

Key to component parts

- 1 Hexagon-socket screw
- 2 Rating plate
- 3 SIMPLEX control unit
- 4 Body gasket (graphite/CrNi)
- 5 Manual vent valve
- 6 Sealing ring
- 7 DUPLEX control unit
- 8 Sealing plug
- 9 Float lifting lever with separate lever extension
- 10 Cover
- 11 Hexagon-socket screw
- 12 Seat (orifice)
- 13 Seat gasket for SIMPLEX/DUPLEX control unit
- 14 Protective sleeve against wear
- 15 Body
- 16 Hexagon nut
- 17 Fixing stud
- 18 Hexagon-socket screw
- 19 Sightglass flange
- 20 Gasket (graphite/CrNi)
- 21 Glass water-level gauge
- 22 Sightglass
- 23 SIMPLEX/DUPLEX-MAX control unit
- 24 Deflector
- 25 Support
- 26 Bracket
- 27 Thermostatic capsule 5N2 (venting)
- 28 Air venting pipe
- 29 Hexagon-socket screw
- 30 Body lid
- 31 Non-return valve unit, complete
- 32 Sealing ring
- 61 Sealing ring

UNA 23h/v, UNA 25h/v, UNA 26h/v, UNA 27h

Depending on their type of body, the float traps can be installed in horizontal or vertical pipes with downward flow.



Danger

The equipment is under pressure and hot during operation. Risk of injuries and severe burns to the entire body.

Only perform installation and maintenance work when the equipment is not under pressure (0 bar) and is cold (20 °C).

Before performing installation or maintenance work, isolate the equipment from upstream and downstream pressure, and vent it.

Sharp edges on inner parts present a danger of cuts to hands. Always wear industrial gloves when working on the equipment.

Flanged design

1. Ensure the correct installation position. Rating plate ② must always face upwards.
2. Ensure the correct direction of flow. The direction of flow arrow is on the trap body.
3. Leave sufficient space for servicing. When the steam trap is installed, a minimum space of 130 mm (DN 15-25) or 200 mm (DN 40, 50) is required for removing cover ⑩, ②② or body lid ③①
4. Remove the plastic plugs. They are used **only** as transit protection.
5. Clean the sealing surfaces of both flanges.
6. Install the steam trap.

Screwed end version

1. Ensure the correct installation position. Rating plate ② must always face upwards.
2. Ensure the correct direction of flow. The direction of flow arrow is on the trap body.
3. Leave sufficient space for servicing. When the steam trap is installed, a minimum space of 130 mm (DN 15-25) or 200 mm (DN 40, 50) is required for removing cover ⑩, ②② or body lid ③①
4. Remove the plastic plugs. They are used **only** as transit protection.
5. Clean the internal thread.
6. Install the steam trap.

Socket-weld version

1. Ensure the correct installation position. Rating plate ② must always face upwards.
 2. Ensure the correct direction of flow. The direction of flow arrow is on the trap body.
 3. Leave sufficient space for servicing. When the steam trap is installed, a minimum space of 130 mm (DN 15-25) or 200 mm (DN 40, 50) is required for removing cover ⑩, ②② or body lid ③①
 4. Remove the plastic plugs. They are used **only** as transit protection.
 5. Clean the socket weld end.
 6. Install **only** using arc welding (welding process 111 and 141 ISO 4063), or equivalent standard.
-

Butt-weld version

1. Ensure the correct installation position. Rating plate ② must always face upwards.
2. Ensure the correct direction of flow. The direction of flow arrow is on the trap body.
3. Leave sufficient space for servicing. When the steam trap is installed, a minimum space of 130 mm (DN 15-25) or 200 mm (DN 40, 50) is required for removing cover ⑩, ②② or body lid ③①
4. Remove the plastic plugs. They are used **only** as transit protection.
5. Clean the butt weld ends
6. Install using arc welding (welding process 111 and 141 to ISO 4063) or gas welding (welding process 3 to ISO 4063), or equivalent standard.

Attention

- ▶ Steam traps may only be welded in pipes by welders with test certification to DIN EN 287 or equivalent qualifications.
-



Heat treatment of welds

Subsequent heat treatment of welds is only necessary if stipulated for the material, e.g. for 1.7335 (13CrMo4-5) / A182-F12 (not a standard material).

Manual vent valve

1. Remove sealing plug **8**.
 2. Fit manual vent valve **5** with sealing ring **6**.
For torques, see the **Torques table**.
 3. Close the manual vent valve.
-

Tools

- Combination spanner 22 mm AF, DIN 3113, form B
 - Torque wrench 20–120 Nm, DIN ISO 6789
-

Float lifting lever (optional extra)

1. Pay attention to the Danger note on page 4.
 2. Remove sealing plug **8**.
 3. Fit float lifting lever **9** with sealing ring **6**. During installation, connect the lever extension and hold vertically. For torques, see the **Torques table**.
- valvesgo.com

Bringing into Service

UNA 23h/v, UNA 25h/v, UNA 26h/v, UNA 27h

The flanged connections, manual vent valve and float lifting lever are firmly secured to the trap, ensuring a tight, leakproof joint.

If the trap is to be used in a new system that has not yet been flushed, the equipment must be inspected and possibly cleaned after bringing into service for the first time.



Danger

The equipment is under pressure and hot during operation. Risk of injuries and severe burns to the entire body.

Only perform installation and maintenance work when the equipment is not under pressure (0 bar) and is cold (20 °C).

Before performing installation or maintenance work, isolate the equipment from upstream and downstream pressure, and vent it.

Sharp edges on inner parts present a danger of cuts to hands.

Always wear industrial gloves when working on the equipment.

Operation

Manual vent valve

1. Pay attention to the Danger note on page 4!
2. If necessary, open the manual vent valve.
3. After the venting process, firmly close the manual vent valve.

Float lifting lever

1. Pay attention to the Danger note on page 4!
2. Connect the lever extension to float lifting lever ⑨.
3. Move float lifting lever ⑨ as shown by the direction arrow on cover ⑩ / ⑫ or the arrow on the trap body (UNA27h).
4. Move the float lifting device in the opposite direction to the arrow (close), and remove the lever extension.

Maintenance

We recommend periodic tests and maintenance to ensure correct functioning of the equipment. For critical applications, we recommend continuous monitoring.



Danger

The equipment is under pressure and hot during operation. Risk of injuries and severe burns to the entire body.

Only perform installation and maintenance work when the equipment is not under pressure (0 bar) and is cold (20 °C).

Before performing installation or maintenance work, isolate the equipment from upstream and downstream pressure, and vent it.

Sharp edges on inner parts present a danger of cuts to hands. Always wear industrial gloves when working on the equipment.

Checking the steam trap

The BK 15 steam trap can be checked during operation using a GESTRA VAPOPHONE® ultrasonic measuring unit or TRAPtest®.

If live steam leakage is detected, clean the trap or replace the regulator.

Cleaning/replacing the control unit

1. Pay attention to the Danger note on page 4!
2. Undo and remove hexagon bolts **1** and hexagon nuts **16** and remove cover **10**, **22** or lid **30** from body **15**.
3. Undo hexagon-socket screws **11** / **29** and remove control unit **3**, **7** or **23** and orifice **12**.
4. Replace control unit **3**, **7** or **23** and orifice **12** if they show visible signs of wear or damage.
5. Clean the body and inner parts. Clean all sealing surfaces.
6. Coat all threads, the sealing surface that has contact with the orifice and the sealing surface of cover **10** / **22** with heat-resistant lubricant (e.g. OKS 217).
7. Insert orifice **12** and new seat gasket **13**, attach control unit **3**, **7** or **23** and tighten screws **11** / **29** alternately and evenly. For torques, see the **Torques table**
8. Insert new body gasket **4**.
9. Place the cover/lid on the body. Tighten hexagon-socket screws **1** or hexagon nuts **16** alternately and evenly. For torques, see the **Torques table**.

Replacing the air venting unit (DUPLEX-MAX control unit)

1. Pay attention to the Danger note on page 4!
2. Undo and remove hexagon-socket screws **1** or hexagon nuts **16** and remove cover **10** / **22** from body **15**.
3. Detach bracket **26** from air venting pipe **28** and remove thermostatic capsule **27**.
4. With a screwdriver, lever air venting pipe **28** off support **25**. **Fig. 5**
5. Undo and remove support **25**.
6. Clean the body and inner parts. Clean all sealing surfaces.
7. Coat the thread of new support **25** and the sealing surface of cover **10** / **22** with heat-resistant lubricant (e.g. OKS 217). Do **not** coat the cone of support **25** with lubricant!
8. Insert support **25** and new sealing ring **6** in body **15**. For torque, see the **Torques table**
9. Place new air venting pipe **28** on support **25**, align vertically and firmly knock the support twice to fix in position. **Fig. 6**
10. Put on a new thermostatic capsule **27** and push bracket **26** over the capsule.
11. Insert new body gasket **4**.
12. Place the cover on the body. Tighten hexagon-socket screws **1** or hexagon nuts **16** alternately and evenly. For torques, see the **Torques table**.

Tools

- Combination spanner 17, 19, 22, 24 mm AF, DIN 3113, form B
- Torque wrench 10–60 Nm, 60–120 Nm, 120 – 300 Nm, DIN ISO 6789
- Allen key 5, 6, 10 mm AF, DIN ISO 2936
- Screwdriver (5.5/125), DIN 5265
- Punch (120/10), DIN 7250
- Hammer (500 g), DIN 1041

Cleaning/replacing the sightglass

1. Pay attention to the Danger note on page 4!
2. Undo and remove hexagon-socket screws **18** and remove sightglass flange **19** from sightglass **22** .
3. Remove and clean glass water-level gauge **21** .
4. Replace glass water-level gauge **21** and gaskets **20** if they show visible signs of wear or damage.
5. Clean all sealing surfaces.
6. Coat all threads and the sealing surface of the flange with heat-resistant lubricant (e.g. OKS 217).
7. Insert glass water-level gauge **21** with new gaskets **20** , put on sightglass flange **19** and tighten hexagon-socket screws **18** alternately and evenly. For torques, see the **Torques table**



Attention

Do not change the factory setting of the thermostat.
 If it is changed inadvertently, the factory setting must be restored.
 When the ball float is pressed right down, dimension **X** should be as follows:

Type	Nominal size	Rolling ball regulator (DUPLEX control unit)	Dimension X
UNA 23h/v, UNA 25h/v, UNA 26h/v, UNA 26h stainless steel	DN 15 - 25	Control unit up to 13 bar (soft bellows)	34.5 mm
	DN 15 - 25	Control unit up to 32 bar (hard bellows)	32.0 mm
	DN 40, 50	Control unit 2 to 32 bar	46.5 mm
UNA 27h	DN 15 - 25	Control unit 16 to 45 bar	32.0 mm
	DN 40, 50	Control unit 16 to 45 bar	46.5 mm

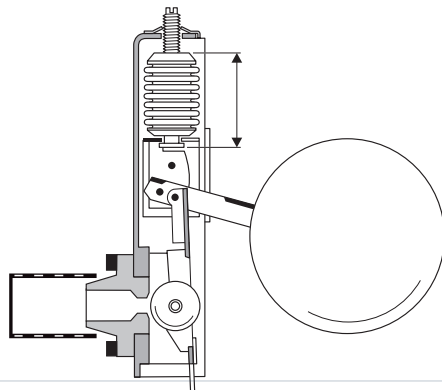

Fig. 9

Torques

Designation	Torques [Nm]							
	UNA 23h/v		UNA 25h/v UNA 26h/v		UNA 26h Stainless steel		UNA 27h	
	DN 15-25	DN 40, 50	DN 15-25	DN 40, 50	DN 15-25	DN 40, 50	DN 25	DN 40, 50
Hexagon-socket screw 1	40 ¹⁾		60 ¹⁾		60			
Manual vent valve 5	75	75	75	75	140	140	140	140
Sealing plug 8	75	75	75	75	140	140	140	140
Float lifting lever 9	75	75	75	75	140	140	170	170
Hexagon-socket screw 11	5	10	5	10	5	10	5	10
Seat (orifice) 12							180	240
Hexagon nut 16	40 ²⁾	75	60 ²⁾	115		180	115	115
Hexagon-socket screw 18	15	15						
Support 25		75		75		75		75
Hexagon-socket screw 29		7		7		7		7

1) UNA..h for installation in horizontal pipes 2) UNA..v for installation in vertical pipes

Spare parts list for UNA 23h/v, UNA 25h/v, UNA 26h/v

Item	Designation	Stock code	Stock code		
		DN 15 – 25	DN 40 + 50		
4	Body gasket ¹⁾ (graphite/CrNi)	560 491	560 492		
6	Sealing ring ¹⁾	560 486	560 486		
20	Sightglass gasket ²⁾ (graphite/CrNi)	560 487	560 488		
20 21	Glass water-level gauge with gasket	560 481	560 480		
13	Seat gasket ¹⁾ (graphite/CrNi)	560 489	560 490		
	Seat gasket ²⁾ (graphite/CrNi), MAX control unit		560 547		
4 7 11 12 13	DUPLEX control unit, complete	ORIFICE 2	560 073	560 088	
		ORIFICE 4	560 074	560 089	
		ORIFICE 4 MAX		560 575	
		ORIFICE 8	560 075	560 090	
	4 6 12 13 23 25 26 27 28 29	DUPLEX-MAX control unit, complete	ORIFICE 8 MAX		560 576
			ORIFICE 13	560 076	560 091
			ORIFICE 13 MAX		560 577
			ORIFICE 22	560 077	560 092
			ORIFICE 22 MAX		560 578
			ORIFICE 32	560 078	560 093
	ORIFICE 32 MAX		560 579		
3 4 11 12 13	SIMPLEX control unit, complete	ORIFICE 2	560 067	560 082	
		ORIFICE 4	560 068	560 083	
		ORIFICE 4 MAX		560 580	
		ORIFICE 8	560 069	560 084	
	4 12 13 23 29	SIMPLEX-MAX control unit, complete	ORIFICE 8 MAX		560 581
			ORIFICE 13	560 070	560 085
			ORIFICE 13 MAX		560 582
			ORIFICE 22	560 071	560 086
			ORIFICE 22 MAX		560 583
			ORIFICE 32	560 072	560 087
	ORIFICE 32 MAX		560 584		

¹⁾ Min. order quantity 20 items.

²⁾ Min. order quantity 10 items. For smaller quantities, please contact your specialist retailer.

Spare parts list for UNA 23h/v, UNA 25h/v, UNA 26h/v continued

Item	Designation	Stock code	Stock code	
		DN 15 – 25	DN 40 + 50	
3 4 11 13	SIMPLEX control unit, complete, but without orifice	560 079	560 094	
4 7 11 13	DUPLEX control unit up to 13 bar, complete, but without orifice	560 080	560 095	
4 7 11 13	DUPLEX control unit above 13 bar, complete, but without orifice	560 081	560 096	
11 12 13	Orifice, complete but without control unit	ORIFICE 2	560 040	560 046
		ORIFICE 4	560 041	560 047
		ORIFICE 4 MAX		560 570
		ORIFICE 8	560 042	560 048
		ORIFICE 8 MAX		560 571
		ORIFICE 13	560 043	560 049
		ORIFICE 13 MAX		560 572
		ORIFICE 22	560 044	560 050
		ORIFICE 22 MAX		560 573
		ORIFICE 32	560 045	560 051
ORIFICE 32 MAX		560 574		
5 6	Manual vent valve with sealing ring	560 676		
6 25 26 27 28	Air venting unit, complete, for DUPLEX-MAX control unit		560 548	

Spare parts list for UNA 26h stainless steel

Item	Designation	Stock code	Stock code		
		DN 15 – 25	DN 40 + 50		
4	Body gasket ¹⁾ (graphite/CrNi)	560 491	560 492		
5	Sealing ring ²⁾	560 514	560 514		
13	Seat gasket ¹⁾ (graphite/CrNi)	560 489	560 490		
	Seat gasket ²⁾ (graphite/CrNi), MAX control unit		560 547		
4 7 11 12 13 4 6 12 13 23 25 26 27 28 29	DUPLEX control unit, complete	ORIFICE 2	560 394	560 388	
		ORIFICE 4	560 395	560 389	
		ORIFICE 4 MAX		560 575	
		ORIFICE 8	560 396	560 390	
	DUPLEX-MAX control unit, complete	ORIFICE 8 MAX		560 576	
		ORIFICE 13	560 397	560 391	
		ORIFICE 13 MAX		560 577	
		ORIFICE 22	560 398	560 392	
		ORIFICE 22 MAX		560 578	
		ORIFICE 32	560 399	560 393	
		ORIFICE 32 MAX		560 579	
		3 4 11 12 13 4 12 13 23 29	SIMPLEX control unit, complete	ORIFICE 2	560 097
	ORIFICE 4			560 098	560 105
	ORIFICE 4 MAX				560 580
ORIFICE 8	560 099			560 106	
SIMPLEX-MAX control unit, complete	ORIFICE 8 MAX			560 581	
	ORIFICE 13		560 100	560 107	
	ORIFICE 13 MAX			560 582	
	ORIFICE 22		560 101	560 108	
	ORIFICE 22 MAX			560 583	
	ORIFICE 32		560 102	560 109	
ORIFICE 32 MAX		560 584			

1) Min. order quantity 20 items.

2) Min. order quantity 10 items. For smaller quantities, please contact your specialist retailer.

Spare parts list for UNA 26h stainless steel continued

Item	Designation	Stock code	Stock code	
		DN 15 – 25	DN 40 + 50	
3 4 11 13	SIMPLEX control unit, complete, but without orifice	560 103	560 110	
4 7 11 13	DUPLEX control unit up to 13 bar, complete, but without orifice	560 401	560 403	
4 7 11 13	DUPLEX control unit above 13 bar, complete, but without orifice	560 400	560 402	
11 12 13	Orifice, complete but without control unit	ORIFICE 2	560 111	560 117
		ORIFICE 4	560 112	560 118
		ORIFICE 4 MAX		560 570
		ORIFICE 8	560 113	560 119
		ORIFICE 8 MAX		560 571
		ORIFICE 13	560 114	560 120
		ORIFICE 13 MAX		560 572
		ORIFICE 22	560 115	560 121
		ORIFICE 22 MAX		560 573
		ORIFICE 32	560 116	560 122
ORIFICE 32 MAX		560 574		
5 6	Manual vent valve with sealing ring	560 676		
6 25 26 27 28	Air venting unit, complete, for DUPLEX-MAX control unit		560 548	

Spare parts list for UNA 27h

Item	Designation	Stock code	
		DN 25	DN 40 + 50
4	Body gasket (graphite/CrNi) 1)	560 621	560 622
6	Sealing ring 1)	560 514	560 514
4 7 11 12 13	DUPLEX control unit, complete ORIFICE 16 ORIFICE 28 ORIFICE 45	560 376	560 379
		560 377	560 380
		560 378	560 381
3 4 11 12 13	SIMPLEX control unit, complete ORIFICE 16 ORIFICE 28 AO = Abschlussorgan ORIFICE 45	560 370	560 373
		560 371	560 374
		560 372	560 375
3 4 11	SIMPLEX control unit, complete, but without orifice	560 366	560 368
4 7 11	DUPLEX control unit, complete, but without orifice	560 367	560 369
11 12 13	Orifice, complete but without control unit ORIFICE 16 ORIFICE 28 ORIFICE 45	560 384	560 387
		560 383	560 386
		560 382	560 385
31 32	Non-return valve unit, complete	560 406	560 407
5 6	Manual vent valve with sealing ring	560 076	
9 61	Manual vent valve with sealing ring	560 063	560 064

Taking out of Service



Danger

The equipment is under pressure and hot during operation. Risk of injuries and severe burns to the entire body.

Only perform installation and maintenance work when the equipment is not under pressure (0 bar) and is cold (20 °C).

Before performing installation or maintenance work, isolate the equipment from upstream and downstream pressure, and vent it.

Sharp edges on inner parts present a danger of cuts to hands.

Always wear industrial gloves when working on the equipment.



Attention

- ▶ If there is a risk of frost, drain the trap.

Disposal

Dismantle the equipment and separate waste materials, using the materials specification as a reference (see **Technical Data**).

The equipment must be disposed of in accordance with statutory waste disposal regulations.

valvesgo.com

valvesgo.com



Agencies all over the world: www.gestra.de

valvesgo.com

GESTRA AG

Münchener Strasse 77

28215 Bremen

Germany

Tel. +49 421 3503-0

Fax +49 421 3503-393

E-mail info@de.gestra.com

Web www.gestra.com