

AE14

Automatic Air Vents for Liquid Systems

Installation and Maintenance Instructions

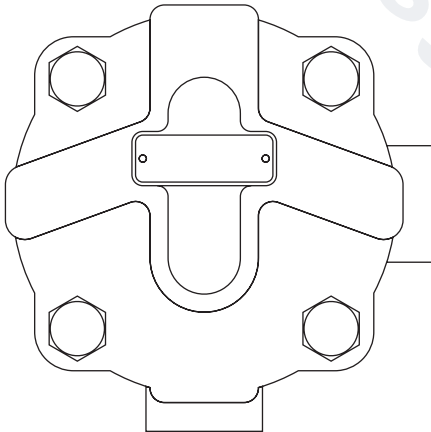



1. Safety information
2. General product information
3. Installation
4. Commissioning
5. Operation
6. Maintenance
7. Spare parts

1. Safety information

Safe operation of these products can only be guaranteed if they are properly installed, commissioned, used and maintained by qualified personnel (see Section 1.11 on this document) in compliance with the operating instructions. General installation and safety instructions for pipeline and plant construction, as well as the proper use of tools and safety equipment must also be complied with.

1.1 Intended use

Referring to the Installation and Maintenance Instructions, name-plate and Technical Information Sheet, check that the product is suitable for the intended use/application. The products listed below comply with the requirements of the EU Pressure Equipment Directive / UK Pressure Equipment (Safety) Regulations and carry the  mark when so required. It should be noted that products rated as 'SEP' are required by the Directive not to carry the  mark.

The products fall within the following Pressure Equipment Directive categories:

Product	Group 1 Gases	Group 2 Gases	Group 1 Liquids	Group 2 Liquids
AE14	-	SEP	-	SEP

- i) The product has been specifically designed for use on water/condensate which are in Group 2 of the above mentioned Pressure Equipment Directive.
- ii) Check material suitability, pressure and temperature and their maximum and minimum values. If the maximum operating limits of the product are lower than those of the system in which it is being fitted, or if malfunction of the product could result in a dangerous overpressure or overtemperature occurrence, ensure a safety device is included in the system to prevent such over-limit situations.
- iii) Determine the correct installation situation and direction of fluid flow.
- iv) Spirax Sarco products are not intended to withstand external stresses that may be induced by any system to which they are fitted. It is the responsibility of the installer to consider these stresses and take adequate precautions to minimise them.
- v) Remove protection covers from all connections before installation.

1.2. Access

Ensure safe access and if necessary a safe working platform (suitably guarded) before attempting to work on the product. Arrange suitable lifting gear if required.

1.3. Lighting

Ensure adequate lighting, particularly where detailed or intricate work is required.

1.4. Hazardous liquids or gases in the pipeline

Consider what is in the pipeline or what may have been in the pipeline at some previous time. Consider: flammable materials, substances hazardous to health, extremes of temperature.

1.5. Hazardous environment around the product

Consider: explosion risk areas, lack of oxygen (e.g. tanks, pits), dangerous gases, extremes of temperature, hot surfaces, fire hazard (e.g. during welding), excessive noise, moving machinery.

1.6. The system

Consider the effect on the complete system of the work proposed. Will any proposed action (e.g. closing isolation valves, electrical isolation) put any other part of the system or any personnel at risk?

Dangers might include isolation of vents or protective devices or the rendering ineffective of controls or alarms. Ensure isolation valves are turned on and off in a gradual way to avoid system shocks.

1.7. Pressure systems

Ensure that any pressure is isolated and safely vented to atmospheric pressure. Consider double isolation (double block and bleed) and the locking or labelling of closed valves. Do not assume that the system has depressurised even when the pressure gauge indicates zero.

1.8. Temperature

Allow time for temperature to normalise after isolation to avoid danger of burns. If parts made from Viton have been subjected to a temperature approaching 315 °C (599 °F) or higher, it may have decomposed and formed hydrofluoric acid. Avoid skin contact and inhalation of any fumes as the acid will cause deep skin burns and damage the respiratory system.

1.9. Tools and consumables

Before starting work ensure that you have suitable tools and/or consumables available. Use only genuine Spirax Sarco replacement parts.

1.10. Protective clothing

Consider whether you and/or others in the vicinity require any protective clothing to protect against the hazards of, for example, chemicals, high/low temperature, radiation, noise, falling objects, and dangers to eyes and face.

1.11. Permits to work

All work must be carried out or be supervised by a suitably competent person. Installation and operating personnel should be trained in the correct use of the product according to the Installation and Maintenance Instructions.

Where a formal 'permit to work' system is in force it must be complied with. Where there is no such system, it is recommended that a responsible person should know what work is going on and, where necessary, arrange to have an assistant whose primary responsibility is safety.

Post 'warning notices' if necessary.

1.12. Handling

Manual handling of large and/or heavy products may present a risk of injury. Lifting, pushing, pulling, carrying or supporting a load by bodily force can cause injury particularly to the back. You are advised to assess the risks taking into account the task, the individual, the load and the working environment and use the appropriate handling method depending on the circumstances of the work being done.

1.13. Residual hazards

In normal use the external surface of the product may be very hot. If used at the maximum permitted operating conditions the surface temperature of some products may reach temperatures of 100 °C (212 °F).

Many products are not self-draining. Take due care when dismantling or removing the product from an installation (refer to 'Maintenance instructions').

1.14. Freezing

Provision must be made to protect products which are not self-draining against frost damage in environments where they may be exposed to temperatures below freezing point.

1.15. Safety information - Product specific

See the relevant Sections of the attached Installation and Maintenance Instructions for specific details relating to these products.

1.16. Disposal

Unless otherwise stated in the Installation and Maintenance Instructions, this product is recyclable and no ecological hazard is anticipated with its disposal providing due care is taken, except:

Viton:

- Can be landfilled, when in compliance with National and Local regulations.
- Can be incinerated, but a scrubber must be used to remove Hydrogen Fluoride, which is evolved from the product and with compliance to National and Local regulations.
- Is insoluble in aquatic media.

1.17. Returning products

Customers and stockists are reminded that under EC Health, Safety and Environment Law, when returning products to Spirax Sarco they must provide information on any hazards and the precautions to be taken due to contamination residues or mechanical damage which may present a health, safety or environmental risk. This information must be provided in writing including Health and Safety data sheets relating to any substances identified as hazardous or potentially hazardous.

2. General product information

2.1 Description

AE14 The AE14 is a range of float type air vents for liquid systems. The body and cover are manufactured in SG iron and the complete unit is readily maintainable. The standard version with a viton valve cone is designated AE14. This model is also available with an inbuilt stop valve fitted to the inlet port designated AE14SV and AE14ESV.

AE14E The AE14E version has an EPDM valve cone. This model is also available with an inbuilt stop valve fitted to the inlet port designated the AE14ESV.

AE14S The AE14S is a stainless steel valve cone version.

Available types

AE14 Fitted with a viton valve head (standard version)

AE14E Fitted with an EPDM valve head

AE14S Fitted with a stainless steel valve head

AE14SV Fitted with a viton valve head and stop valve

AE14ESV Fitted with an EPDM valve head and stop valve

Standards

These products fully comply with the requirements of the EU Pressure Equipment Directive / UK Pressure Equipment (Safety) Regulations and carry the  mark when so required.

Certification

The product is available with material certification to EN 10204 2.2.

Note: All certification/inspection requirements must be stated at the time of order placement.

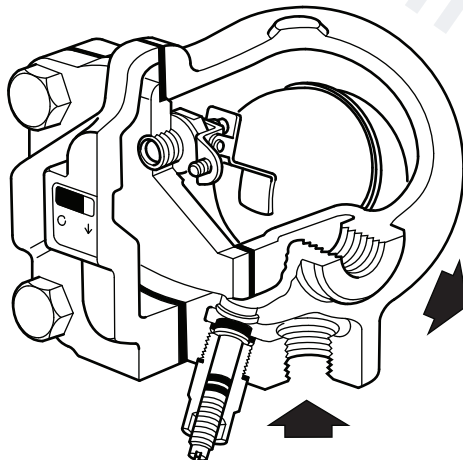

Fig. 1 AE14SV and AE14ESV

3. Installation

Note: Before actioning any installation observe the 'Safety information' in Section 1.

Warning

The cover gasket and the main valve assembly gasket contains a thin stainless steel support ring which may cause physical injury if not handled and disposed of carefully.

Referring to the Installation and Maintenance Instructions, name-plate and Technical Information Sheet, check that the product is suitable for the intended installation:

- 3.1** Check materials, pressure and temperature and their maximum values. If the maximum operating limit of the product is lower than that of the system in which it is being fitted, ensure that a safety device is included in the system to prevent overpressurisation.
- 3.2** Determine the correct installation situation and the direction of fluid flow.
- 3.3** Remove protective covers from all connections.
- 3.4** The automatic air vent must be fitted into a vertical plane above the point being vented with the direction of flow as indicated so that the float arm falls and rises vertically. Point the arrow on the name-plate downwards.
We recommend piping the discharge from the air vent to a suitable safe point.

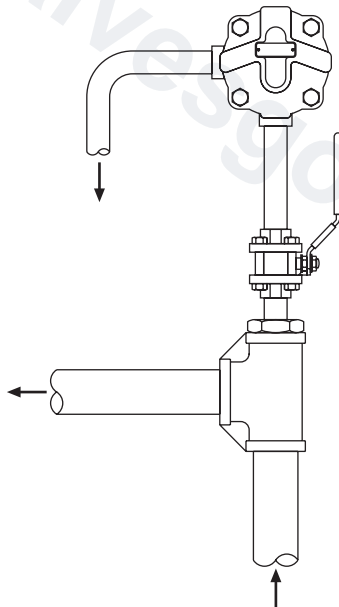

AE14E at high point of a medium temperature hot water (MTHW) system.

*** Note:**
All Spirax Sarco air vents should be installed vertically with the inlet at the bottom.

Note:

If the trap is to discharge to atmosphere ensure it is to a safe place, the discharging air or gas may be at a temperature of 100 °C (212 °F).

Fig. 2

4. Commissioning

After installation or maintenance ensure that the system is fully functional. Carry out tests on any alarms or protective devices.

5. Operation

The AE14 automatic air vent utilises a simple but well proven, float lever valve assembly which opens to air and gases and closes tightly to water.

Once fitted they require no adjustment, either on start-up or subsequent running. Their operation is totally automatic over a variety of light or heavy duty applications.

Float type traps are renowned for their instantaneous load handling capability, clean tight shut-off and resistance to waterhammer and vibration.

6. Maintenance

Note: Before actioning any maintenance programme observe the 'Safety information' in Section 1.

Warning

The cover gasket and the main valve assembly gasket contains a thin stainless steel support ring which may cause physical injury if not handled and disposed of carefully.

6.1 General Information

All work must be carried out by a suitably competent person. Before starting work ensure that suitable tools are available. Use only Spirax Sarco replacement parts. Before attempting work on the trap, ensure that the trap is isolated from the rest of the pressurised system. With the AE14SV and AE14ESV this is simply carried out by using the inbuilt stop valve.

Ensure that any pressure within the isolated section is safely vented to atmosphere. Allow time for the temperature of the trap to normalise after isolation to avoid the danger of burns. When reassembling make sure that all joint faces are clean. After maintenance ensure that the system is fully functioning.

6.2 How to fit the main valve:

- Undo the cover bolts (2) and lift of the cover (4).
- Withdraw the pivot pin (11) to release the float and lever (8) from the pivot frame (10).
- Push out the main valve head (9) and replace with a new one. Reassemble the float and lever (8).
- Check operation by raising and lowering the float several times making sure that the valve head is centring properly on the seat.
- Refit the cover (4) using a new cover gasket (3).
- Tighten cover bolts (2) uniformly to the recommended tightening torque (see Table 1).
- Open up the isolating valves slowly until full system pressure is achieved.
- Check for leaks.

6.3 How to replace the main valve assembly:

- Undo the cover bolts (2) and lift of the cover (4).
- Withdraw pivot pin (11) and release the float and lever (8) from the pivot frame (10).
- Undo main valve assembly screws (7) and remove pivot frame (10).
- Unscrew main valve seat (5) and gasket (6).
- Replace with new and tighten main valve seat (5) to recommended torque (see Table 1).
- Re-assemble the float and lever (8).
- Check operation by raising and lowering the float several times making sure that the valve head is centring properly on the seat.
- Refit the cover (4) using a new cover gasket (3).
- Tighten cover bolts (2) uniformly to the recommended tightening torque (see Table 1).
- Open up the isolating valves slowly until full system pressure is achieved.
- Check for leaks.

6.4 How to fit the stop valve assembly (AE14SV and AE14ESV):

Warning: Before attempting this operation it is essential to isolate the automatic air vent other than by its inbuilt stop valve and to lower the water level.

- Remove the complete stop valve assembly by unscrewing the housing (12).
- Replace with a new stop valve assembly (12, 13, 14), fitting new seals (15) and gaskets (16) tighten to the recommended tightening torques (see Table 1).
- After re-commissioning ensure that the new inbuilt stop valve is in the open position.

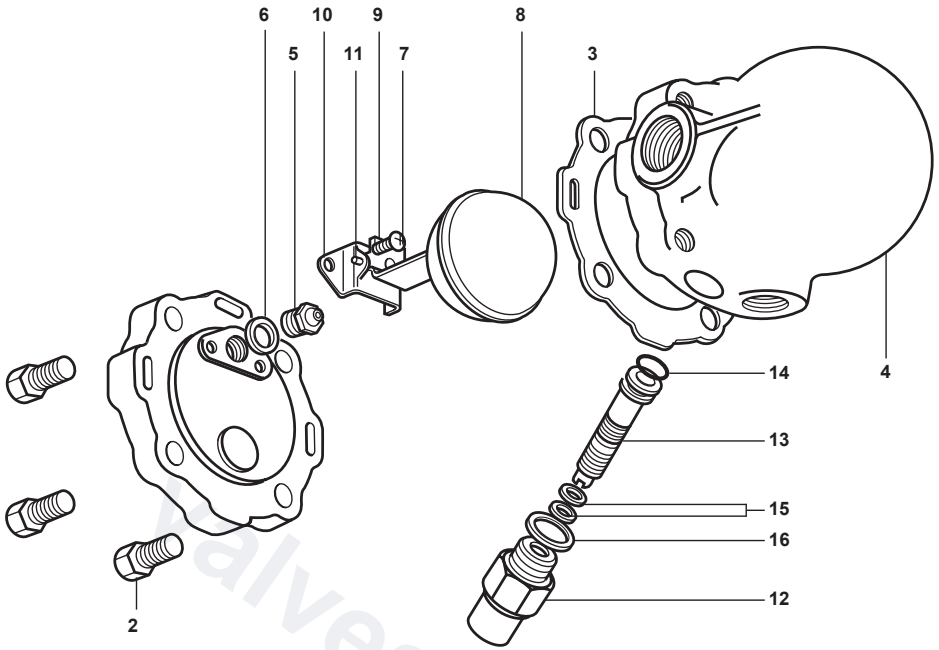



Fig. 3

Table 1 Recommended tightening torques

Item	Part		or mm		N m	(lbf ft)
2	Cover bolts	17 A/F		M10 x 30	47 - 50	35 - 37
5	Main valve seat	17 A/F			50 - 55	33 - 40
7	Main valve assembly screws	Pozidrive		M4 x 6	2.5 - 3.0	1.8 - 2.2
12	Stop valve housing	21 A/F			30 - 35	22 - 26

7. Spare parts

The spare parts available are shown in solid outline. Parts drawn in a grey line are not supplied as spares.

Available spares

Maintenance kit **3, 5, 6, 7 (2 off), 8, 9, 10, 11, 14, 15 (2 off), 16**

Note: Item 9 is attached to item 8 when supplied for the AE14S.

Seal kit **3, 5 (EPDM), 14, 15 (2 off), 16**

Valve head (not available for the AE14S) packet of 3 **9**

Note: 1 off EPDM and Viton valve head is supplied to fit as required.

How to order spares

Always order spares by using the description given in the column headed 'Available spares' and state the size and type of automatic air vent.

Example: 1 - Maintenance kit for a Spirax Sarco ½" AE14ESV automatic air vent.

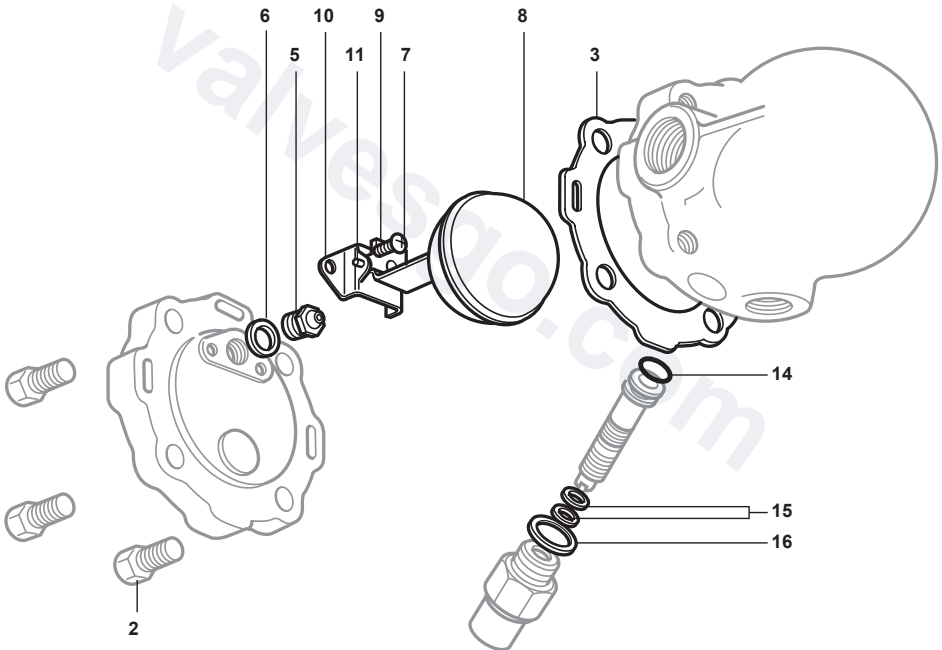

Fig. 4

valvesgo.com

valvesgo.com