



Cert. No. LRQ 0963008

ISO 9001

spirax sarco

TI-P402-91
AB Issue 11

LP10-4 Level Probe

Description

The Spirax Sarco LP10-4 level probe is used with the Spirax Sarco LC1300 level controller to provide on / off level control and alarm functions in steam boilers, tanks or other vessels.

The four tip probe is particularly suitable where 3-lamp 'electric gauge glass' alarm / level indicators are fitted. The probe body is earthed through its screwed connection and the boiler or tank normally forms the earth return path. The probe may also be used in concrete or plastic tanks by using one of the tips as an earth return, or by providing a separate earth rod or plate. The LP10-4 probe has four detachable level sensing tips which are cut to length on installation to give the required switching levels. Note: Tips are ordered separately. When a tip is immersed in conductive liquid it completes an electrical circuit to earth. When the level drops below the tip, the resistance to earth becomes high, indicating to the controller that the tip is out of the liquid.

Approvals:

The LP10-4 is also available with a 1" NPT screwed connection, approved to UL61010. **Please note that this version will not be CE marked and is not suitable for Europe.**

Caution:

The probe is not suitable for outside installation without additional environmental protection.

Available tip lengths mm (inches)

Tips are 1 000 mm (39.4") long. Two sets of tips may be connected for a maximum probe length of 2 095 mm (82.5")

Pressure/temperature limits

Nominal pressure rating	PN40	
Maximum pressure	32 bar g	(464 psi g)
Maximum temperature	239°C	(462°F)
Maximum ambient temperature	70°C	(158°F)
Minimum ambient temperature	-20°C	(-4°F)

Technical data

Protection rating	IP54	
Maximum cable length (probe to controller)	30 m	(98 ft)
Maximum sensing depth	2 095 mm	(82.5")
Minimum sensing depth	75 mm	(3")
Minimum conductivity (when used with an LC1300 level controller) 1 µS/cm @ 25°C (77°F).		

Materials

No.	Description	Material	
1	Probe body	Austenitic stainless steel	BS EN 10088-3 (1.4306)
2	Probe tips	Austenitic stainless steel	Type 316/316L
3	Tip insulation sleeving	PFA (Per Fluor Alkoxy)	
4	Lower housing	PPS (Polyphenylene sulphide)	
5	Upper housing	PPS (Polyphenylene sulphide)	
6	Gland support pad	Thermoplastic elastomer	
7	Cable gland	PA (Polyamide)	
8	Tip steady	PEEK (Polyaryletherketone)	Grade 450G

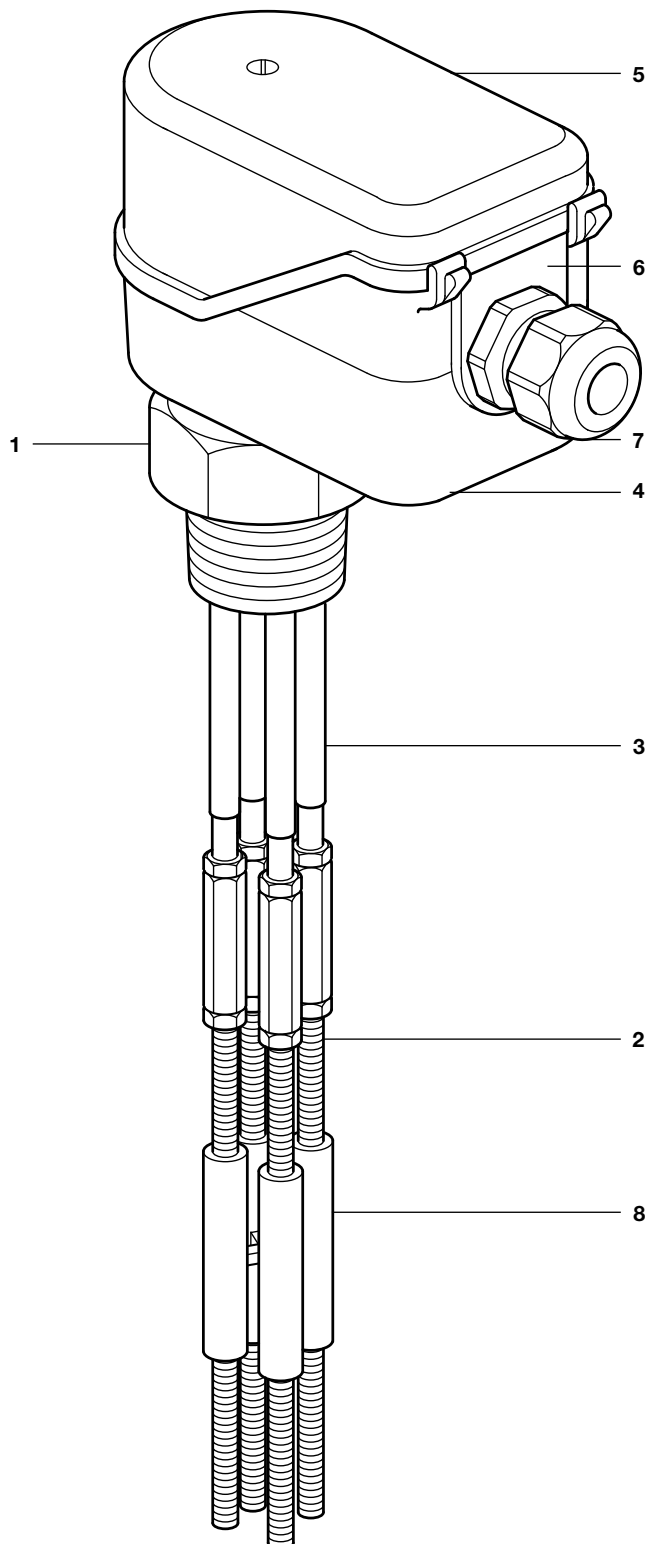

Safety information, installation and maintenance
 This document does not contain sufficient information to install the product safely. See the Installation and Maintenance Instructions supplied with the unit for full details.

Warning: This product contains materials including plastics which can give off toxic fumes if exposed to excessive heat.

Installation note:

The LP10-4 is designed for installation in a BSP Rp1 (1" BSP tapered) or 1" NPT threaded flange or cover. **Note: Always specify one of these threads for new installations.**
 A minimum 80 mm (3") nominal bore protection tube is recommended if installing the probe in a boiler, or in a tank which is subject to very turbulent conditions.
 Additional environmental protection is needed for installation outdoors.

Wiring note:

Wiring is straightforward on the LP10-4, as crimp connectors are used. Extra connectors are available as a spares kit. Terminal posts are colour coded for easy identification.
 The wiring loom may be disconnected and removed without disturbing the cable gland by lifting the gland carrier out of the lower housing.

Maintenance note:

No special maintenance is required, though boiler water level controls do require periodic testing and inspection which is described in separate literature.

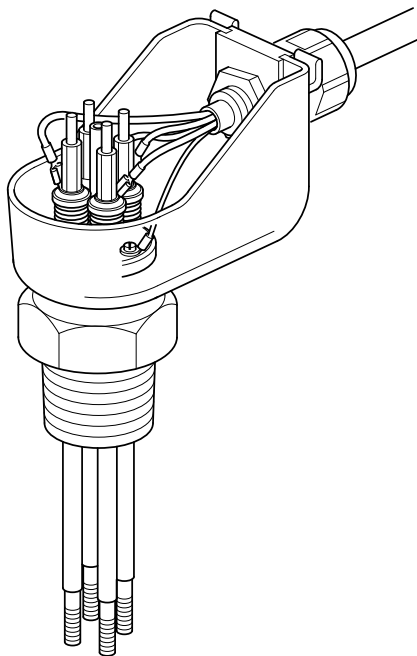

Dimensions/weight (approximate) in mm (in) and kg (lb)

A	B	C	D	Weight
60	25	75	50	1.15
(2.4)	(1.0)	(3.0)	(2.0)	(2.5)

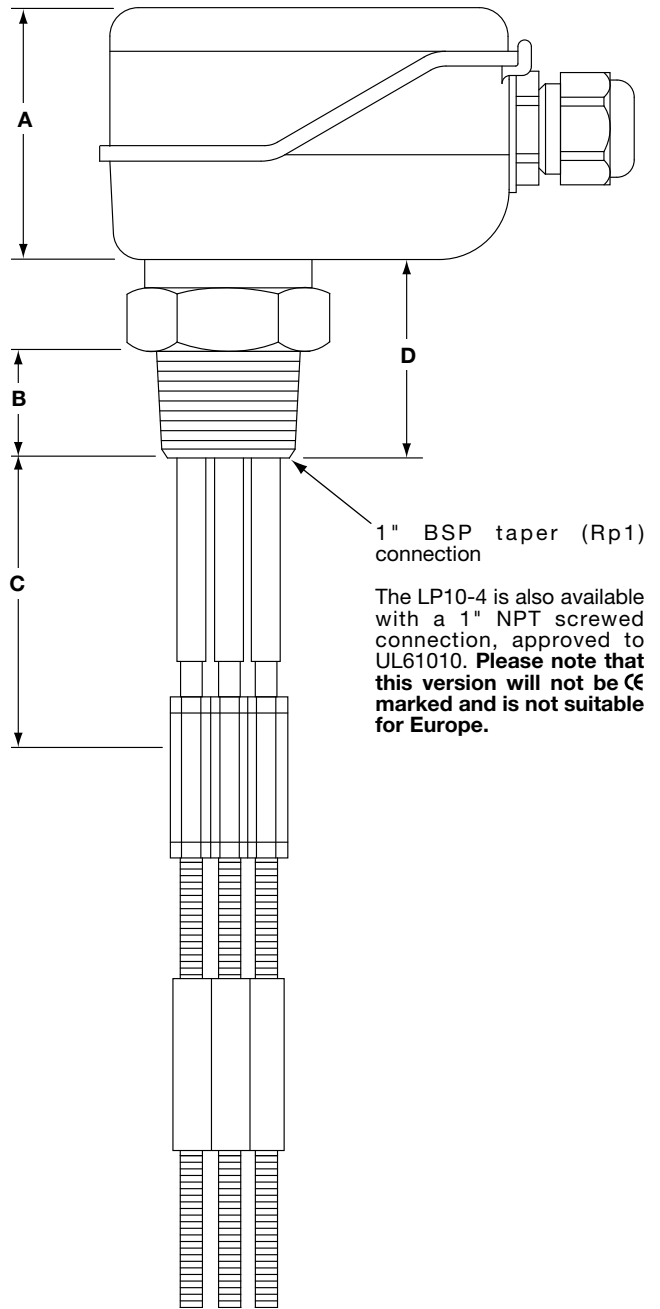

How to specify

Conductivity probe with austenitic stainless steel body and probe tips, PFA tip insulation, suitable for steam boiler operation up to 32 bar g @ 239°C.

How to order

Example: 1 off Spirax Sarco LP10-4 probe (BSP) with 1000 mm tip assembly.

Available spares

LP10-4 connector set (electrical)

Comprising: 6 flat crimp connectors and 2 ring crimps.

LP10-4 tip mounting kit

Comprising: 1 set of 4 tip connectors, 8 lock-nuts and 2 tip supports.