

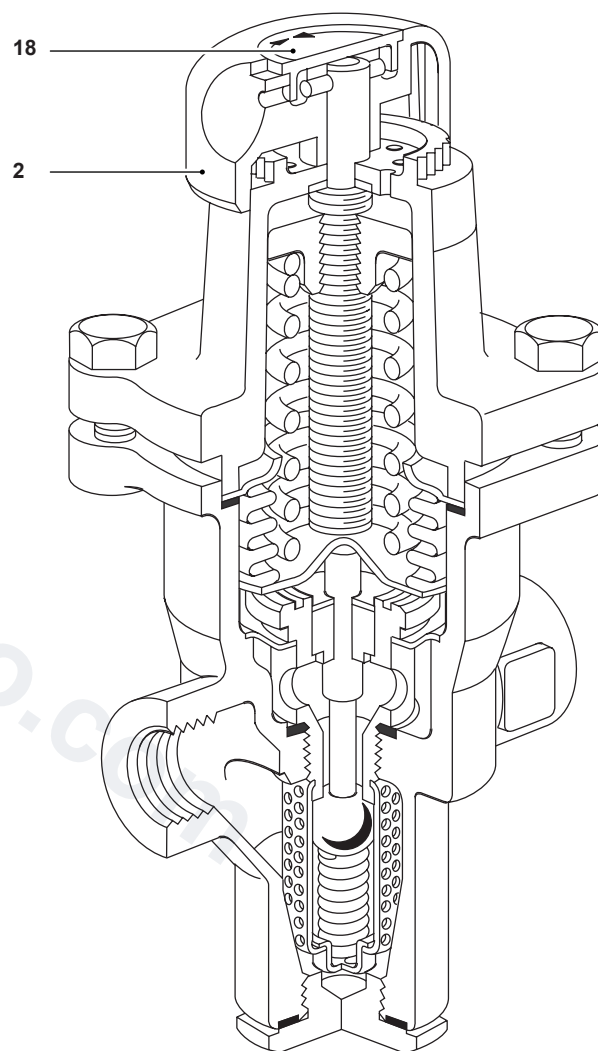

SRV2S

Stainless Steel Pressure Reducing Valve



Description

The SRV2S is a compact, stainless steel, direct acting pressure reducing valve designed for applications using steam or gases such as compressed air. All wetted parts are constructed in 316L stainless steel. SRV2S pressure reducing valves are supplied with one of three colour coded springs which are identified by the disc (18) located on the adjustment handwheel (2):

Grey	For downstream pressure control:	0.14 to 1.7 bar g (2.03 to 24.7 psi g)
Green	For downstream pressure control:	1.40 to 4.0 bar g (20.3 to 58.0 psi g)
Orange	For downstream pressure control:	3.50 to 8.6 bar g (50.8 to 125 psi g)

Note: Where control spring ranges overlap always use the lower range to give better control.

Standards

This product fully complies with the requirements of the Pressure Equipment Directive (PED).

Certification

This product is available with certification to EN 10204 3.1.

Note: All certification/inspection requirements must be stated at the time of order placement.

Sizes and pipe connections

½", ¾" and 1" screwed BSP (BS 21 Rp) or NPT.

DN15, DN20 and DN25 Flanged EN 1092 PN25 and ANSI 150.

Pressure/temperature limits

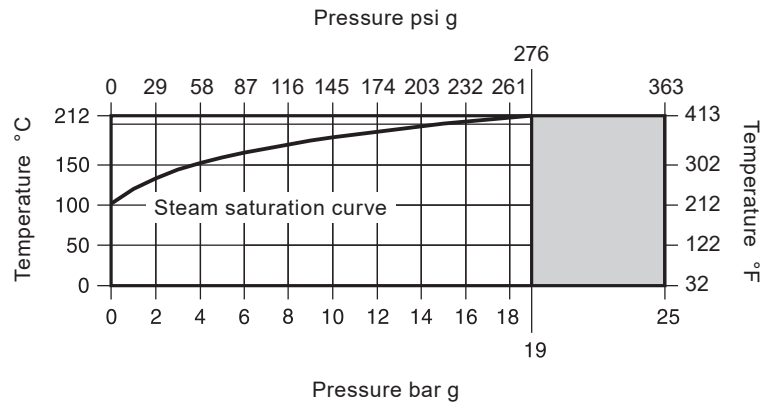

The product **must not** be used in this region.

Body design conditions	PN25	
Maximum design pressure	25 bar g @ 120 °C	363 psi g @ 248 °F
Maximum design temperature	212 °C @ 19 bar g	414 °F @ 276 psi g
Minimum allowable temperature	0 °C	32 °F
Maximum operating pressure for saturated steam service	19 bar g	276 psi g
Maximum operating temperature	212 °C @ 19 bar g	414 °F @ 276 psi g
Minimum operating temperature	0 °C	32 °F
Note: For lower operating temperatures consult Spirax Sarco		
Maximum downstream reduced pressure	8.6 bar g	125 psi g
Maximum differential pressure	19 bar	276 psi
Maximum recommended turndown ratio 10:1 at maximum flow		
Designed for a maximum cold hydraulic test pressure of:	38 bar g	551 psi g
Note: With internals fitted, test pressure must not exceed:	19 bar g	276 psi g

Materials

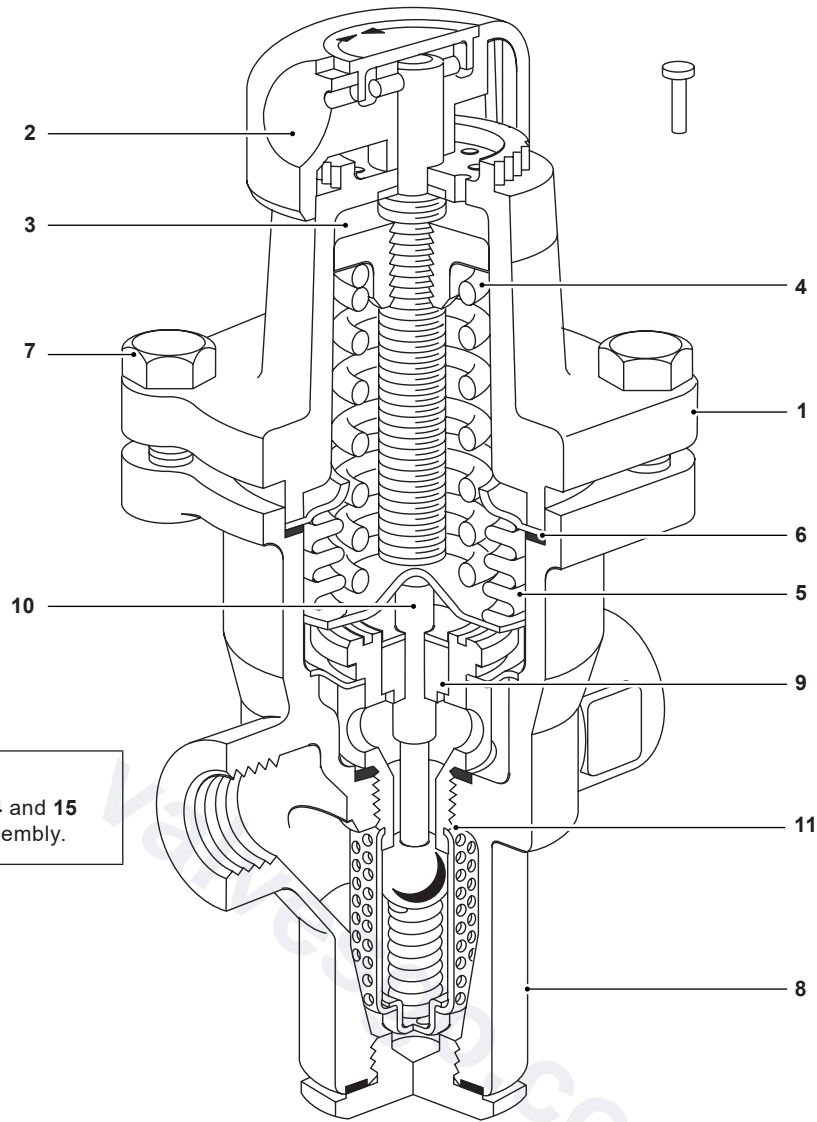

Note:
Items 9, 10, 11, 13, 14 and 15
are all part of one assembly.

No.	Part	Material	
1	Spring housing	Aluminium	LM6 Electroless nickel finish
2	Adjustment handwheel	Plastic	Polypropylene
3	Top spring plate	Cast iron	DIN 1691 GG 20 Electroless nickel finish
4	Pressure adjustment spring	Silicon chrome spring steel	BS 2803 685 A55 Range 2 Electroless nickel finish
5	Bellows assembly	Stainless steel	316Ti/316L
6	Bellows assembly gasket	Reinforced exfoliated graphite	
7	Hex. bolt (M8 x 25 mm)	Stainless steel	BS 6105 A 270
8	Body	Stainless steel	DIN 1.4404 BS 3100 316 C12 ASTM A351 CF 3M External electropolish finish
9	Guide bush	Graphite filled PTFE	
10	Pushrod	Stainless steel	ASTM A276 316L BS 3100 316 C 12
11	Valve seat	Stainless steel	ASTM A351 CF 3M DIN 1.4404

Materials continued on next page

Materials (continued)

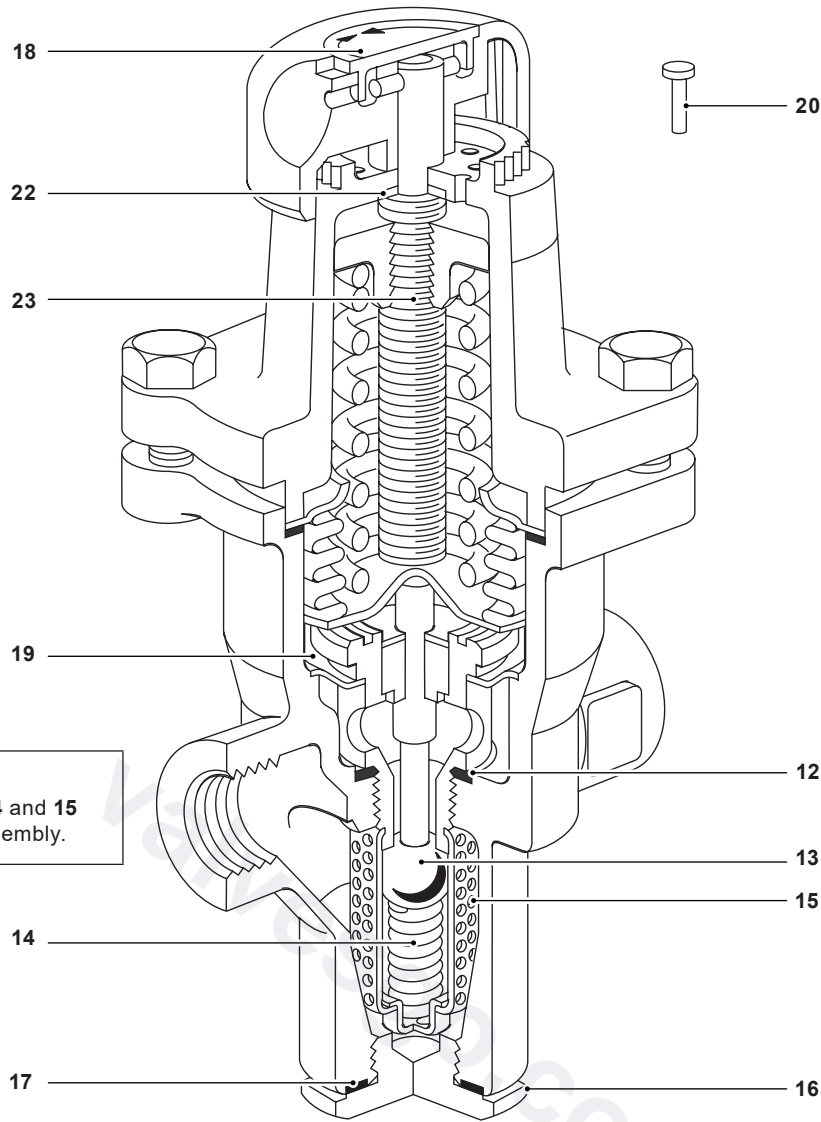

No.	Part	Material	
12	Valve seat gasket	Stainless steel	BS 1449 316 S11
13	Valve	Stainless steel	316L
14	Valve return spring	Stainless steel	BS 2056 316 S42
15	Strainer screen	Stainless steel	BS 1449 316 SH
16	Bottom cap	Stainless steel	ASTM A276 316L
17	Bottom 'O' ring	PTFE	
18	Spring range identity disc	Plastic	Polypropylene
19	Bulkhead plate	Stainless steel	BS 1449 316 S13 AISI 316L
20	Tamper-proof pin	Mild steel copper plated	
21	Flanges (not shown)	Stainless steel	DIN 1.4404 BS 3100 316 C12 ASTM A351 CF 3M Electropolish finish
22	Washer	Stainless steel	316L
23	Drive spindle	Carbon steel	BS 970 230 M07 Electroless nickel finish

Capacities for safety valve sizing

Full lift capacities for safety valve sizing purposes :	Size	DN15 (½")	DN20 (¾")	DN25 (1")	For conversions: Cv (UK) = Kv x 0.963 Cv (US) = Kv x 1.156
	Kv	1.5	2.5	3.0	

Steam and compressed air capacities

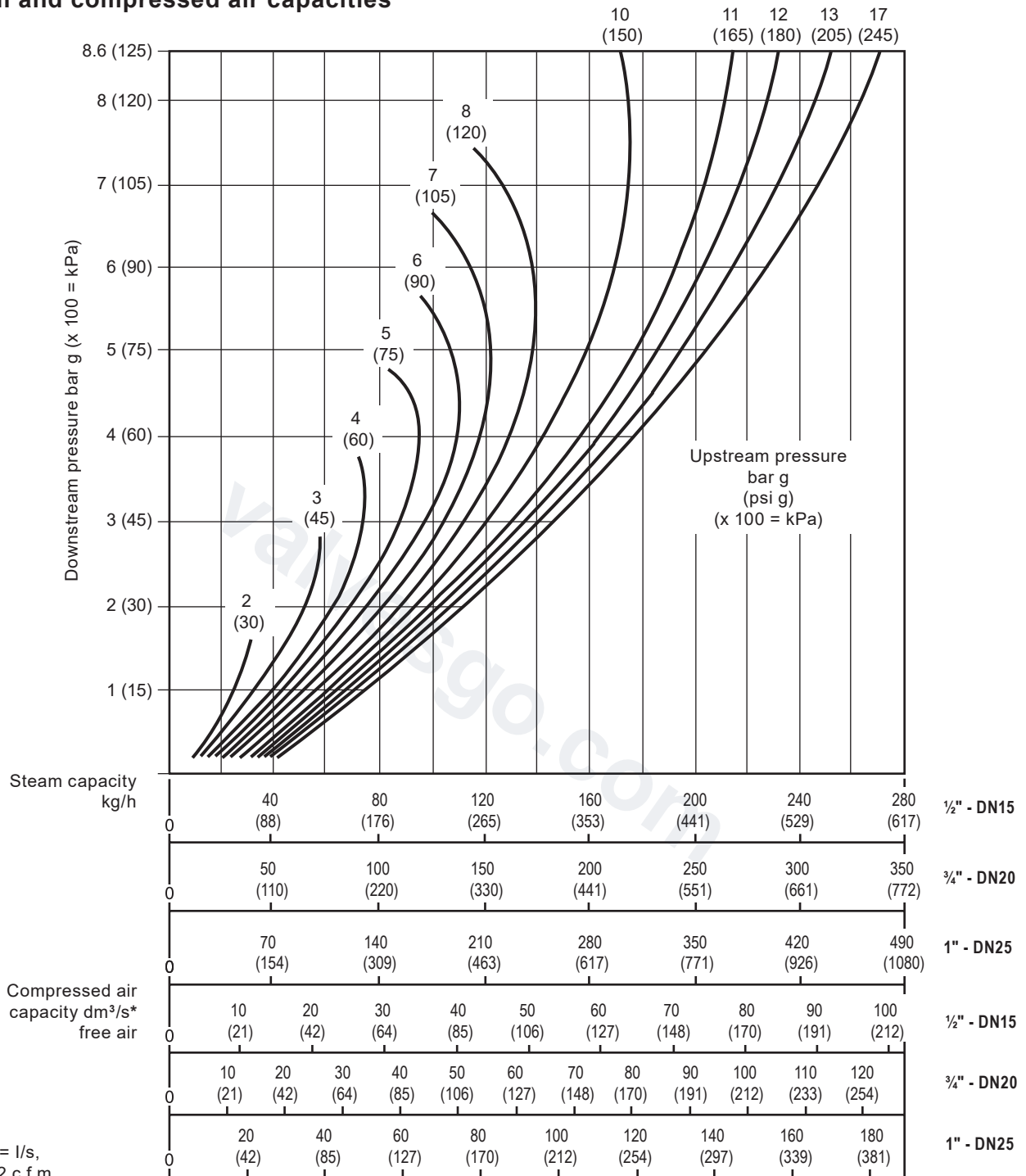

* dm³/s = l/s,
1 l/s ≈ 2 c.f.m.

How to use the chart

The curved lines labelled 2, 3, 4, 5 etc., represent upstream pressures. Downstream pressures are read along the vertical line on the left hand side of the chart.

How to use the chart is best described by an example:-

Required, a pressure reducing valve to pass 120 kg/h reducing from 8 to 6 bar. From the downstream pressure of 6 bar on the left hand side of the chart extend out horizontally until the line meets the curved 8 bar upstream line. At this point read vertically downwards where it will be seen that a ½" SRV2S will be required.

Dimensions/weights (approximate) in mm (in) and kg (lb)

Size		A	B		C	D	* E1	* E2	Weight		
									Screwed	Flanged	
½"	BSP/NPT	83 (3.3)			62 (2.4)	130 (5.1)	25 (0.98)	15 (0.59)		1.48 (3.26)	
	PN25		150 (5.91)						97 (3.82)		3.1 (6.83)
	ANSI 150			140 (5.51)					91 (3.58)		2.4 (5.29)
¾"	BSP/NPT	96 (3.8)			62 (2.4)	130 (5.1)	25 (0.98)	15 (0.59)		1.58 (3.48)	
	PN25		150 (5.91)						107 (4.21)		3.8 (8.38)
	ANSI 150			140 (5.51)					100 (3.94)		2.8 (6.17)
1"	BSP/NPT	108 (4.3)			62 (2.4)	130 (5.1)	25 (0.98)	15 (0.59)		1.70 (3.75)	
	PN25		160 (6.3)						117 (4.61)		4.4 (9.7)
	ANSI 150			153 (6.02)					110 (4.33)		3.6 (7.94)

* Note: E1 and E2 are withdrawal distances for maintenance.

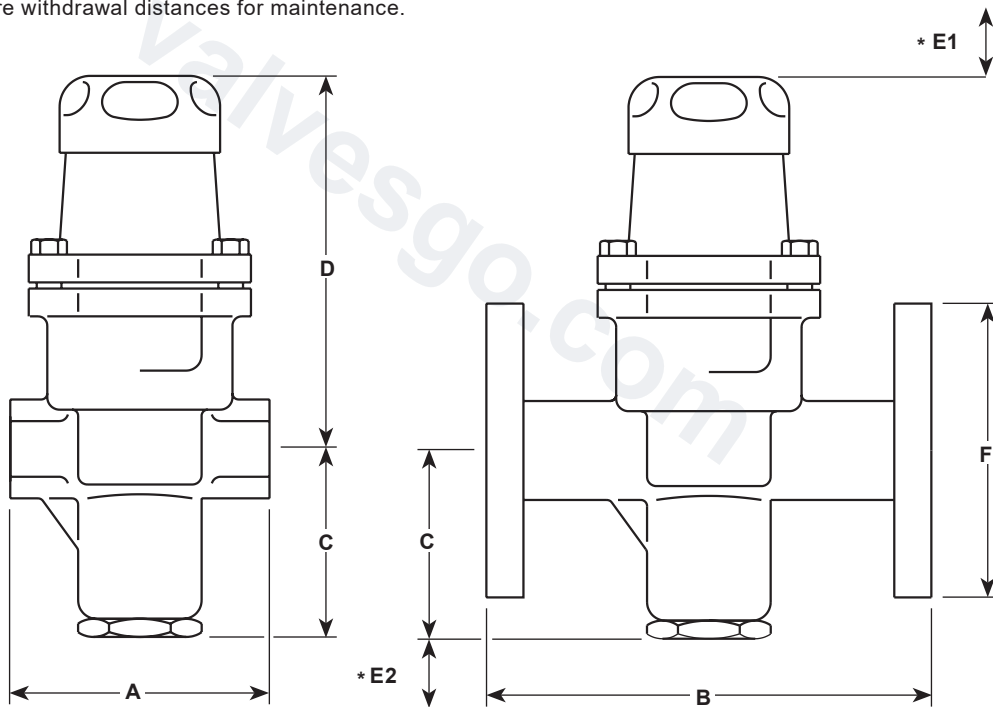

Safety information, installation and maintenance

For full details see the Installation and Maintenance Instructions (IM-P186-03) supplied with the product.

Installation note:

The valve should be installed in a horizontal pipeline with the direction of flow as indicated by the arrow on the valve body.

How to order

Example: 1 off Spirax Sarco ½" screwed BSP SRV2S pressure reducing valve with stainless steel body and bellows, fitted with an orange spring for a downstream pressure control of 3.5 to 8.6 bar g (50.8 to 125 psi g).

Spare parts

The spare parts available are shown in heavy outline. Parts drawn in a grey line are not supplied as spares.

Available spares

	Grey	0.14 to 1.7 bar g (2.03 to 24.7 psi g)	4, 18
* Pressure adjustment spring	Green	1.40 to 4.0 bar g (20.3 to 58.0 psi g)	4, 18
	Orange	3.50 to 8.6 bar g (50.8 to 125 psi g)	4, 18
* Bellows (Stainless steel)			5, 6
* Spring housing hex. bolts (set of 4)			7
Valve and seat assembly			6, 11, 12, 15, 19
* Set of gaskets/'O' rings			6, 12, 17

* Common to all sizes.

How to order spares

Always order spares by using the description given in the column headed 'Available spares' and state the size, type and pressure range of the reducing valve.

Example: 1 off Pressure adjustment spring (orange), having a downstream pressure range of 3.5 to 8.6 bar g (50.8 to 125 psi g) for a Spirax Sarco DN15 (½") SRV2S pressure reducing valve.

