

TD42

Thermodynamic Steam Trap

Installation and Maintenance Instructions

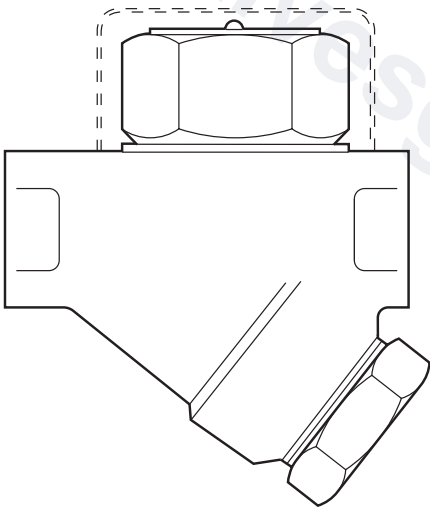

1. Safety information
2. General product information
3. Installation
4. Commissioning
5. Operation
6. Maintenance
7. Spare parts

valvesgo.com

1. Safety information

Safe operation of this product can only be guaranteed if it is properly installed, commissioned, used and maintained by qualified personnel (see Section 1.11) in compliance with the operating instructions. General installation and safety instructions for pipeline and plant construction, as well as the proper use of tools and safety equipment must also be complied with.

1.1 Intended use

Referring to the Installation and Maintenance Instructions, name-plate and Technical Information Sheet, check that the product is suitable for the intended use / application. This product complies with the requirements of the European Pressure Equipment Directive 2014/68/EU and falls within category 'SEP'.

It should be noted that products within this category are required by the Directive not to carry the  mark.

- i) This product has been specifically designed for use on steam, air or condensate / water, which is in Group 2 of the above mentioned Pressure Equipment Directive. The products' use on other fluids may be possible but, if this is contemplated, Spirax Sarco should be contacted to confirm the suitability of the product for the application being considered.
- ii) Check material suitability, pressure and temperature and their maximum and minimum values. If the maximum operating limits of the product are lower than those of the system in which it is being fitted, or if malfunction of the product could result in a dangerous overpressure or overtemperature occurrence, ensure a safety device is included in the system to prevent such over-limit situations.
- iii) Determine the correct installation situation and direction of fluid flow.
- iv) Spirax Sarco products are not intended to withstand external stresses that may be induced by any system to which they are fitted. It is the responsibility of the installer to consider these stresses and take adequate precautions to minimise them.
- v) Remove protection covers from all connections and protective film from all name-plates, where appropriate, before installation on steam or other high temperature applications.

1.2 Access

Ensure safe access and if necessary a safe working platform (suitably guarded) before attempting to work on the product. Arrange suitable lifting gear if required.

1.3 Lighting

Ensure adequate lighting, particularly where detailed or intricate work is required.

1.4 Hazardous liquids or gases in the pipeline

Consider what is in the pipeline or what may have been in the pipeline at some previous time. Consider: flammable materials, substances hazardous to health, extremes of temperature.

1.5 Hazardous environment around the product

Consider: explosion risk areas, lack of oxygen (e.g. tanks, pits), dangerous gases, extremes of temperature, hot surfaces, fire hazard (e.g. during welding), excessive noise, moving machinery.

1.6 The system

Consider the effect on the complete system of the work proposed. Will any proposed action (e.g. closing isolation valves, electrical isolation) put any other part of the system or any personnel at risk? Dangers might include isolation of vents or protective devices or the rendering ineffective of controls or alarms. Ensure isolation valves are turned on and off in a gradual way to avoid system shocks.

1.7 Pressure systems

Ensure that any pressure is isolated and safely vented to atmospheric pressure. Consider double isolation (double block and bleed) and the locking or labelling of closed valves. Do not assume that the system has depressurised even when the pressure gauge indicates zero.

1.8 Temperature

Allow time for temperature to normalise after isolation to avoid danger of burns.

1.9 Tools and consumables

Before starting work ensure that you have suitable tools and/or consumables available. Use only genuine Spirax Sarco replacement parts.

1.10 Protective clothing

Consider whether you and/or others in the vicinity require any protective clothing to protect against the hazards of, for example, chemicals, high/low temperature, radiation, noise, falling objects, and dangers to eyes and face.

1.11 Permits to work

All work must be carried out or be supervised by a suitably competent person.

Installation and operating personnel should be trained in the correct use of the product according to the Installation and Maintenance Instructions.

Where a formal 'permit to work' system is in force it must be complied with. Where there is no such system, it is recommended that a responsible person should know what work is going on and, where necessary, arrange to have an assistant whose primary responsibility is safety.

Post 'warning notices' if necessary.

1.12 Handling

Manual handling of large and/or heavy products may present a risk of injury. Lifting, pushing, pulling, carrying or supporting a load by bodily force can cause injury particularly to the back. You are advised to assess the risks taking into account the task, the individual, the load and the working environment and use the appropriate handling method depending on the circumstances of the work being done.

1.13 Residual hazards

In normal use the external surface of the product may be very hot. If used at the maximum permitted operating conditions the surface temperature of some products may reach temperatures of 500 °C (932 °F).

Many products are not self-draining. Take due care when dismantling or removing the product from an installation (refer to 'Maintenance instructions').

1.14 Freezing

Provision must be made to protect products which are not self-draining against frost damage in environments where they may be exposed to temperatures below freezing point.

1.15 Disposal

Unless otherwise stated in the Installation and Maintenance Instructions, this product is recyclable and no ecological hazard is anticipated with its disposal providing due care is taken.

Please visit the Spirax Sarco product compliance web pages

<https://www.spiraxsarco.com/product-compliance>

for up to date information on any substances of concern that may be contained within this product. Where no additional information is provided on the Spirax Sarco product compliance web page, this product may be safely recycled and/or disposed providing due care is taken. Always check your local recycling and disposal regulations.

1.16 Returning products

Customers and stockists are reminded that under EC Health, Safety and Environment Law, when returning products to Spirax Sarco they must provide information on any hazards and the precautions to be taken due to contamination residues or mechanical damage which may present a health, safety or environmental risk. This information must be provided in writing including Health and Safety data sheets relating to any substances identified as hazardous or potentially hazardous.

2. General product information

2.1 General description

The TD42 range are maintainable thermodynamic steam traps which are suitable for pressures up to 42 bar g, complete with integral strainer and screwed body connections.

The **TD42L** and **TD42LC** are specifically designed for lower capacity applications and therefore, ideal for tracing and mains drainage applications. Note: 'L' and 'LC' denotes lower capacity.

The **TD42** and **TD42H** are specifically designed for higher load applications.

The **TD42A**, **TD42HA**, **TD42LA** and **TD42LCA** are designed for applications where the release of air is a concern. It is supplied with an anti-air-binding disc.

Note: the letter 'A' in the nomenclature denotes that an anti-air-binding disc is used in this product.

The **TD42L**, **TD42LA**, **TD42H** and **TD42HA** have electroless nickel preparation (ENP) body surfaces which is both energy saving and oxidation resistant.

The **TD42**, **TD42A**, **TD42LC** and **TD42LCA** have black body surfaces.

Please note that both the **TD42S2**, and **TD42S3** are socket weld traps and are covered by separate IMI's. See IM-P068-37 for the **TD42S2**, and IM-P068-38 for the **TD42S3**.

Optional extras

Insulating cover: to prevent the trap being unduly influenced by excessive heat loss such as when subjected to low outside temperatures, wind, rain etc.

Integral blowdown valve: A BDV1 or BDV2 can be fitted to the strainer cap, alternatively the strainer cap can be drilled, tapped and plugged $\frac{3}{8}$ " BSP or NPT.

Standards

These products fully comply with the requirements of the European Pressure Equipment Directive 2014/68/EU.

Certification

This product is available with a manufactures Typical Test Report.

Note: All certification/inspection requirements must be stated at the time of order placement.

Note: For additional information see the following Technical Information Sheets: TI-P068-22, TI-P151-04 and TI-S01-03.

2.2 Sizes and pipe connections

TD42	$\frac{3}{8}$ ", $\frac{1}{2}$ "LC, $\frac{1}{2}$ " and $\frac{3}{4}$ " screwed BSP T Rp (ISO 7-1) or API
TD42A	$\frac{3}{8}$ ", $\frac{1}{2}$ "LC, and $\frac{1}{2}$ " screwed BSP T Rp (ISO 7-1) or API
TD42H	$\frac{1}{2}$ ", $\frac{3}{4}$ " and 1" screwed BSP T Rp (ISO 7-1) or NPT
TD42L	$\frac{3}{8}$ ", $\frac{1}{2}$ ", $\frac{3}{4}$ " and 1" screwed BSP T Rp (ISO 7-1) or NPT
TD42HA	$\frac{1}{2}$ " screwed BSP T Rp (ISO 7-1) or NPT
TD42LA	$\frac{3}{8}$ ", $\frac{1}{2}$ ", $\frac{3}{4}$ " and 1" screwed BSP T Rp (ISO 7-1) or NPT
TD42LCA	$\frac{1}{2}$ " screwed BSP T Rp (ISO 7-1)

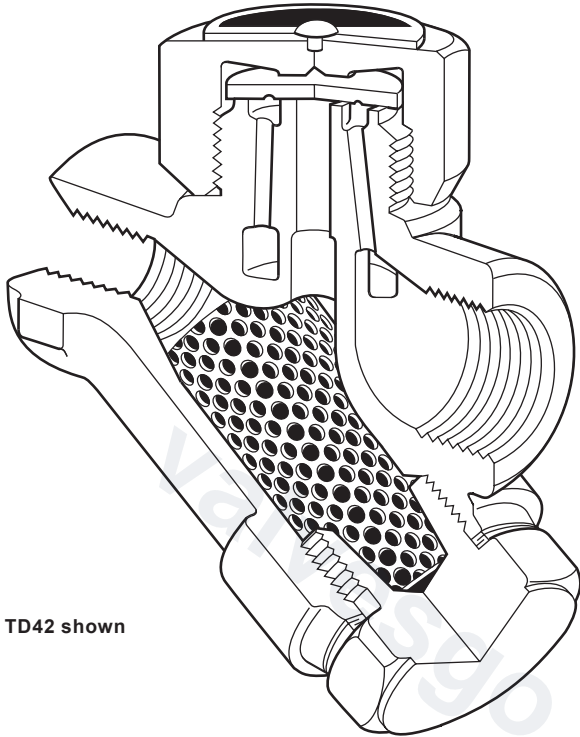

TD42 shown

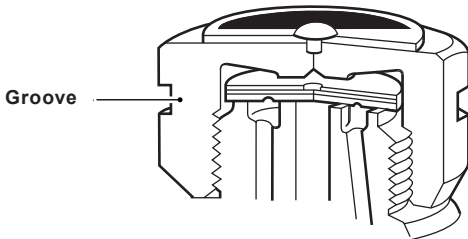

Groove

Groove identifies
 TD42A, TD42LA, TD42LCA and TD42HA versions
 which have an anti-air-binding disc

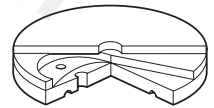

anti-air-binding disc

Fig. 1 TD42 and variants

2.3 Pressure / temperature limits (ISO 6552)

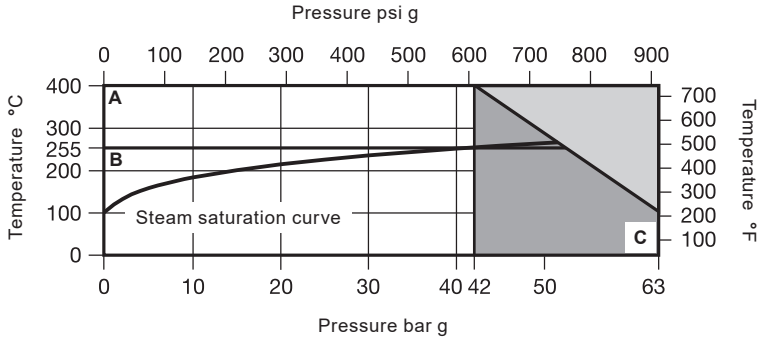

The product **must not** be used in this region.

For optimum product performance the PMO should not exceed 42 bar g.

A - C TD42L and TD42H

B - C TD42LA and TD42HA

Body design conditions		PN63	
PMA	Maximum allowable pressure	63 bar g @ 100 °C	(914 psi g @ 212 °F)
TMA	Maximum allowable temperature	400 °C @ 42 bar g	(752 °F @ 609 psi g)
	Minimum allowable temperature	0 °C	(32 °F)
PMO	Maximum operating pressure	42 bar g	(609 psi g)
		TD42L and TD42H	400 °C @ 42 bar g (752 °F @ 609 psi g)
TMO	Maximum operating temperature	TD42LA and TD42HA	255 °C @ 42 bar g (491 °F @ 609 psi g)
	Minimum operating temperature		0 °C (32 °F)
		TD42L and TD42H	0.25 bar g (4 psi g)
	Minimum inlet pressure for satisfactory operation	TD42LA and TD42HA	0.80 bar g (12 psi g)
PMOB	Maximum operating backpressure should not exceed 80% of the upstream pressure		
	Designed for a maximum cold hydraulic test pressure of:	95 bar g	(1378 psi g)

TD42 Thermodynamic Steam Trap

3. Installation

Note: Before actioning any installation observe the 'Safety information' in Section 1.

Referring to the Installation and Maintenance Instructions, name-plate and Technical Information Sheet, check that the product is suitable for the intended installation:

- 3.1** Check materials, pressure and temperature and their maximum values. If the maximum operating limit of the product is lower than that of the system in which it is being fitted, ensure that a safety device is included in the system to prevent overpressurisation.
- 3.2** Determine the correct installation situation and the direction of fluid flow.
- 3.3** Remove protective covers from all connections and protective film from all name-plates, where appropriate, before installation on steam or other high temperature applications.
- 3.4** The trap should preferably be installed in the horizontal plane, with a small drop leg preceding it. Suitable isolation valves must be installed to allow for safe maintenance and trap replacement. Consideration should be given to a suitable method for testing the correct operation of the trap. This may be a sight glass or a Spiratec system. Sight glasses must be positioned a minimum of 1 m (3 ft) downstream of any blast-action traps. Where the trap discharges into a closed return system, a non-return valve should be fitted downstream to prevent return flow.
- 3.5** Isolation valves must be installed to allow for safe maintenance and trap replacement.
- 3.6** Always open isolation valves slowly until normal operating conditions are achieved - this will avoid system shocks.
- 3.7** Check for leaks and correct operation.

Note: If the trap is to discharge to atmosphere ensure it is to a safe place, the discharging fluid may be at a temperature of 100 °C (212 °F).

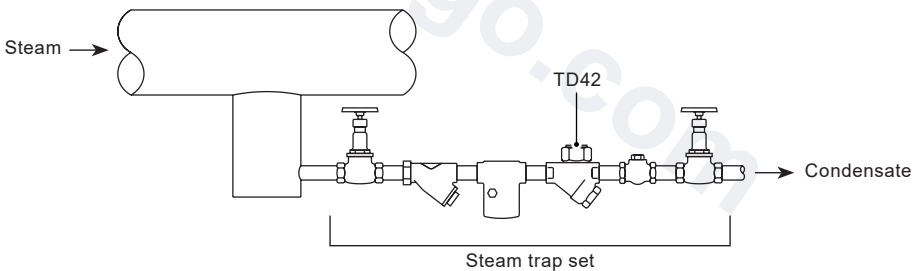

4. Commissioning

After installation or maintenance ensure that the system is fully functional. Carry out tests on any alarms or protective devices.

Fig. 2 Typical application TD42 Thermodynamic Steam Trap

5. Operation

The thermodynamic steam trap will discharge condensate with a blast type action at a few degrees below steam saturation temperature, due care must be given to the site of the discharge.



6. Maintenance

Note: Before actioning any maintenance programme observe the 'Safety information' in Section 1.

6.1 General information:

- Before undertaking any maintenance on the trap it must be isolated from both the supply line and return line and any pressure allowed to safely normalise to atmosphere. The trap should then be allowed to cool.
- When reassembling make sure that the joint faces are clean.
- Maintenance can be completed with the trap in the pipeline, once the safety procedures have been observed.
- It is recommended that new gaskets and spares are used whenever maintenance is undertaken.
- Ensure that the correct tools and necessary protective equipment are used at all times.
- When maintenance is complete open isolation valves slowly and check for leaks.

Table 1 Recommended tightening torques

Item	Part	Size	 or mm		N m	(lbf ft)
2	TD42	($\frac{3}{8}$ "	36 A/F		135 - 150	100 - 110
	TD42	($\frac{1}{2}$ "LC)	36 A/F		135 - 150	100 - 110
	TD42/TD42H	($\frac{1}{2}$ ", $\frac{3}{4}$ "	41 A/F		180 - 200	132 - 147
	TD42L	($\frac{1}{2}$ ", $\frac{3}{4}$ " 1")	36 A/F		135 - 150	100 - 110
	TD42H	(1")	55 A/F		250 - 275	184 - 202
5	(All)		32 A/F	M28	170 - 190	125 - 140

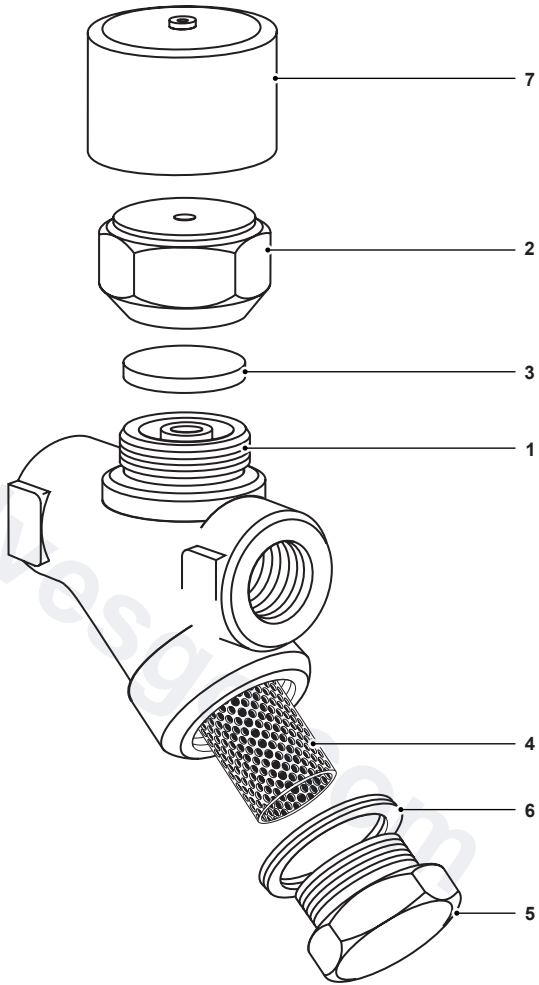

Fig. 3

6.2 How to service

- Remove the insulating cover (7), if fitted, and unscrew the cap (2) using a suitable spanner or socket. **Do not** use stillsons or a wrench of similar type which may cause distortion of the cap.
- If the seating faces on the body are only slightly worn, they can be refaced by lapping on a flat surface, such as a surface plate. A figure-of-eight motion and a little grinding compound, such as 'Carborundum Co's Compound I.F.' gives the best results.

If the wear is too great to be rectified by simple lapping, the seating faces on the body must be ground flat and then lapped.



Note: the disc (3) should always be replaced with a new one. The total amount of metal removed in this way should not exceed 0.25 mm (0.010").

- When reassembling, the disc (3) is normally placed in position with the grooved side in contact with the body seating face (1).
- Screw on the cap (2) to the recommended tightening torque (see Table 1); no gasket is required but a suitable high temperature anti-seize grease should be applied to the threads.

6.3 How to clean or replace the strainer:

- Unscrew the strainer cap (5) using a suitable spanner.
- Withdraw the screen (4) and clean or, if damaged, replace with a new one.
- To reassemble, insert the screen (4) into the strainer cap (5), then screw the strainer cap into place. A fine smear of 'Molybdenum Disulphide' grease should be applied to the first few threads. Care should be taken to ensure that the gasket and gasket faces are clean.
- Tighten to the recommended torque (see Table 1).
- When maintenance is complete open isolation valves slowly and check for leaks.

Table 1 Recommended tightening torques

Item	Part	Size	 or 	N m	(lbf ft)
2	TD42	(3/8")	36 A/F	135 - 150	100 - 110
	TD42	(1/2"LC)	36 A/F	135 - 150	100 - 110
	TD42/TD42H	(1/2", 3/4")	41 A/F	180 - 200	132 - 147
	TD42L	(1/2", 3/4" 1")	36 A/F	135 - 150	100 - 110
	TD42H	(1")	55 A/F	250 - 275	184 - 202
5	(All)		32 A/F M28	170 - 190	125 - 140

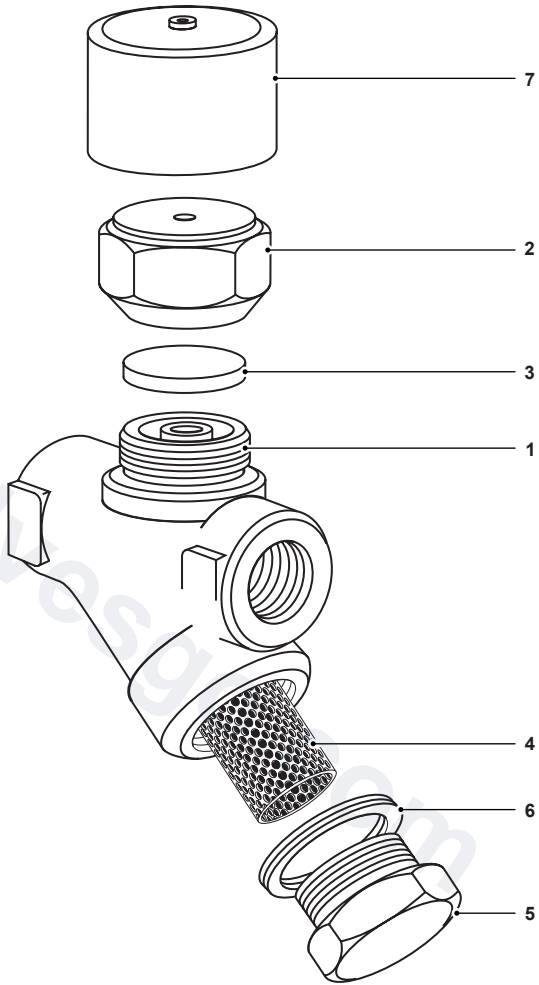

Fig. 3

7. Spare parts

The spare parts available are shown in solid outline. Parts drawn in a grey line are not supplied as spares.

Available spares

Disc (packet of 3)	3
Disc and strainer screen (TD42LA, TD42HA, TD42A or TD42LCA)	3, 4, 6
Strainer screen and gasket	4, 6
Strainer cap gasket (packet of 3)	6
Insulating cover	7

How to order spares

Always order spares by using the description given in the column headed 'Available spares' and state the size and type of trap.

Example:

1 - Strainer screen and gasket for a Spirax Sarco ½" TD42L thermodynamic steam trap.

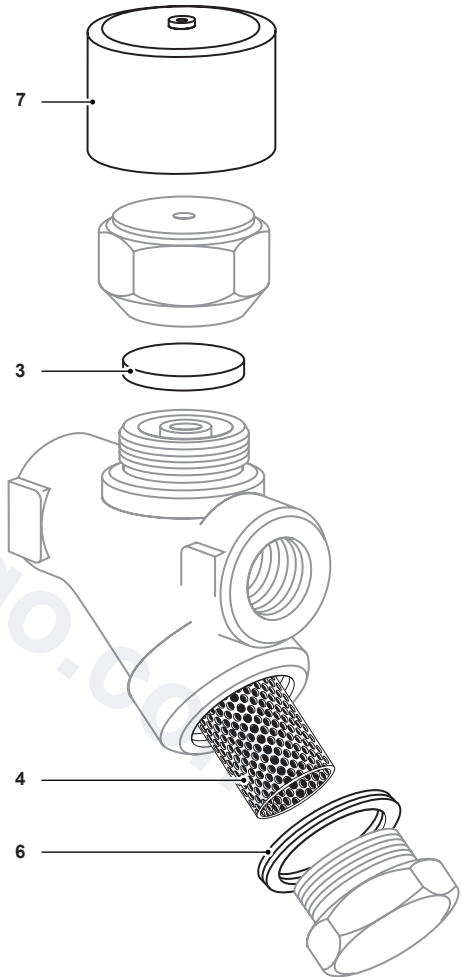

Fig. 4

valvesgo.com

valvesgo.com