

# COSPECT® STEAM PRESSURE REDUCING VALVE

MODEL **COS-21** DUCTILE CAST IRON  
STAINLESS STEEL

## SELF-ACTUATED PRESSURE REDUCING VALVE WITH SHOCK-ABSORBING PISTON

### Features

Technologically advanced pressure reducing valve combined with condensate separator and steam trap provides accurate control and steam conditioning to maximize process system performance.

1. Space-saving unit simplifies system layout, piping and maintenance.
2. Self-aligning shock-absorbing spherical piston and advanced pilot regulator designs maintain secondary steam pressure accuracy, even during adverse process conditions.
3. Built-in cyclone separator, with condensate separation efficiency as high as 98%, and self-modulating free float steam trap provide dry, high-quality steam supply.
4. Major internal components made of stainless steel for long service life.
5. Large surface area integral screens for pilot valve and main valve extend trouble-free service.
6. Internal secondary pressure-sensing channel makes external sensing line unnecessary.
7. Sizes DN 65 and larger have a silencer for noise reduction.



### Pressure Equipment Directive (PED)

Classification according to PED 2014/68/EU, fluid group 2

Size	Category	CE marking
DN 15 to DN 25	—*	Art. 4, Sec. 3 (sound engineering practice), CE marking not allowed
DN 40, DN 50	I	With CE marking and Declaration of Conformity
DN 65 to DN 100	II	With CE marking and Declaration of Conformity

\* Manufactured in accordance with sound engineering practice

### Specifications

Model	COS-21		
Body Material	Ductile Cast Iron (JIS FCD450) (equivalent to GGG40/EN 5.3106)	Ductile Cast Iron (GGG40.3/EN 5.3103)	Cast Stainless Steel (A351/A351M Gr.CF8 or CF8M) (equivalent to 1.4312 or 1.4410)
Connection	Flanged	Flanged	Flanged
	ASME	ASME	DIN
Size	DN 15, 20, 25, 40, 50, 65, 80, 100		DIN
Maximum Operating Pressure (barg)	PMO	21	
Maximum Operating Temperature (°C)	TMO	220	
Primary Pressure Range (barg)	13.5 – 21		
Adjustable Pressure Range (all conditions must be met)	From 5.5 barg to 84% of primary pressure		
	Maximum differential pressure 8.5 bar		
Minimum Adjustable Flow Rate	5% of rated flow rate (For DN 65 – DN 100: 10% of rated flow rate)		

PRESSURE SHELL DESIGN CONDITIONS (NOT OPERATING CONDITIONS): 1 bar = 0.1 MPa

Maximum Allowable Pressure (barg) PMA: 21

Maximum Allowable Temperature (°C) TMA: 220

Minimum Allowable Temperature (°C): 0 (FCD450, GGG40.3/EN 5.3103), -40 (CF8/CF8M)



To avoid abnormal operation, accidents or serious injury, DO NOT use this product outside of the specification range. Local regulations may restrict the use of this product to below the conditions quoted.

## Configuration

No.	Description	Material	DIN*	ASTM/AISI*	
①	Main Body	Ductile Cast Iron GGG40.3/EN 5.3103 (EN-GJS-400-18-LT)	0.7043	A395 Gr.60-40-18	
		Cast Stainless Steel A351/A351M Gr.CF8 or CF8M	1.4312 or 1.4410	—	
		Ductile Cast Iron FCD450	0.7040	A536	
②	Trap Body	Same material as main body			
③	Trap Cover	Same material as main body			
④	Separator	Stainless Steel	—	—	
⑤	Float	Stainless Steel	—	—	
⑥	Float Cover	Ductile Cast Iron	—	—	
⑦	Trap Valve Seat	Stainless Steel	—	—	
⑧	Separator Screen	Stainless Steel	—	—	
⑨	Main Valve Seat	Stainless Steel	—	—	
⑩	Main Valve	Stainless Steel	—	—	
⑪	Main Valve Holder	Stainless Steel	—	—	
⑫	Piston	Stainless Steel	—	—	
⑬	Cylinder	Stainless Steel	—	—	
⑭	Pilot Screen	Stainless Steel	—	—	
⑮	Pilot Screen Holder	Cast Iron and Ductile Cast Iron Models	Carbon Steel S25C	1.1158	AISI1025
		Cast Stainless Steel Models	Stainless Steel SUS303 or A351/A351M Gr.CF8M	1.4305 or 1.4410	AISI303 or —
⑯	Pilot Body	Same material as main body			
⑰	Pilot Valve	Stainless Steel	—	—	
⑱	Pilot Valve Seat	Stainless Steel	—	—	
⑲	Diaphragm	Stainless Steel	—	—	
⑳	Diaphragm Support	Brass	—	—	
㉑	Spring Housing	Same material as main body			
㉒	Coil Spring	Carbon Steel	—	—	
㉓	Adjustment Screw	Cr-Mo Steel	—	—	
㉔	Spanner Cap	Cast Iron and Ductile Cast Iron Models	Die Cast Aluminium	—	—
		Cast Stainless Steel Models	Stainless Steel	—	—
㉕	Plug – Sensing Line Port	Cast Iron and Ductile Cast Iron Models	Carbon Steel SS400	1.0037	A6
		Cast Stainless Steel Models	Stainless Steel SUS304 or A193/A193M Gr.B8M	1.4301 or 1.4401	AISI304 or —
㉖	Pilot Cover	Ductile Cast Iron	0.7040	A536	
㉗	Nameplate	Stainless Steel	—	—	
㉘	Silencer	Stainless Steel	—	—	

\* Equivalent materials

Contact TLV for available replacement parts. All gaskets are PTFE.

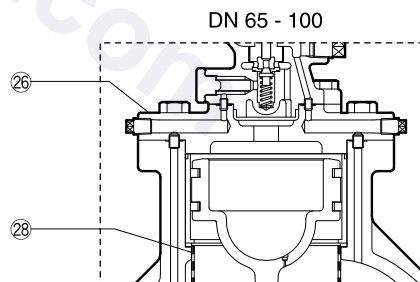
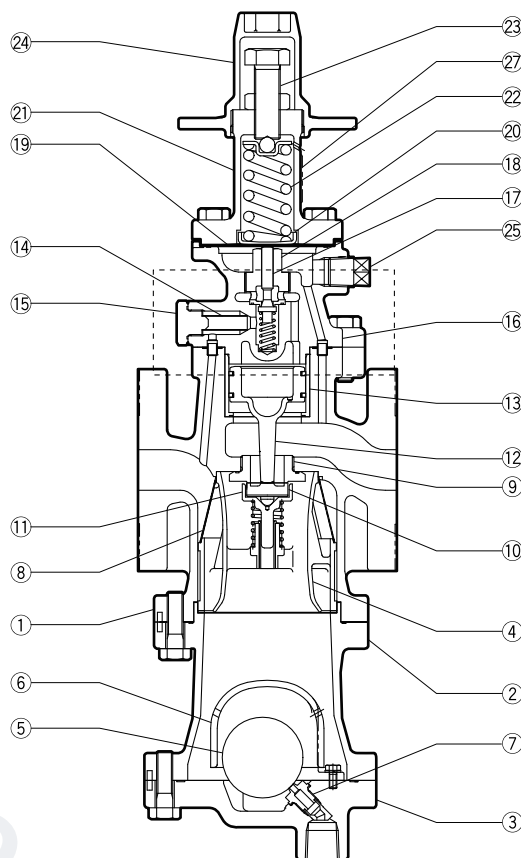

DN 65 - 100  
The parts configuration of sizes DN 65 – 100 differs slightly from that of sizes DN 15 – 50.

## Cv & Kvs Values

	Nominal Valve Size (DN)							
	15	20	25	40	50	65	80	100
Kvs (DIN)	3.3	5.9	9.5	20.6	31.9	50.8	72.9	110
Cv (UK)	3.2	5.7	9.2	20	31	49.4	70.8	107
Cv (US)	3.8	6.9	11.1	24	37.2	59.3	85	128



The Cv & Kvs values shown are for the valve in the full fail open position. These values are not to be used for COS sizing, and instead may be used as one of the factors in calculations for safety valve selection.

### Sizing Chart

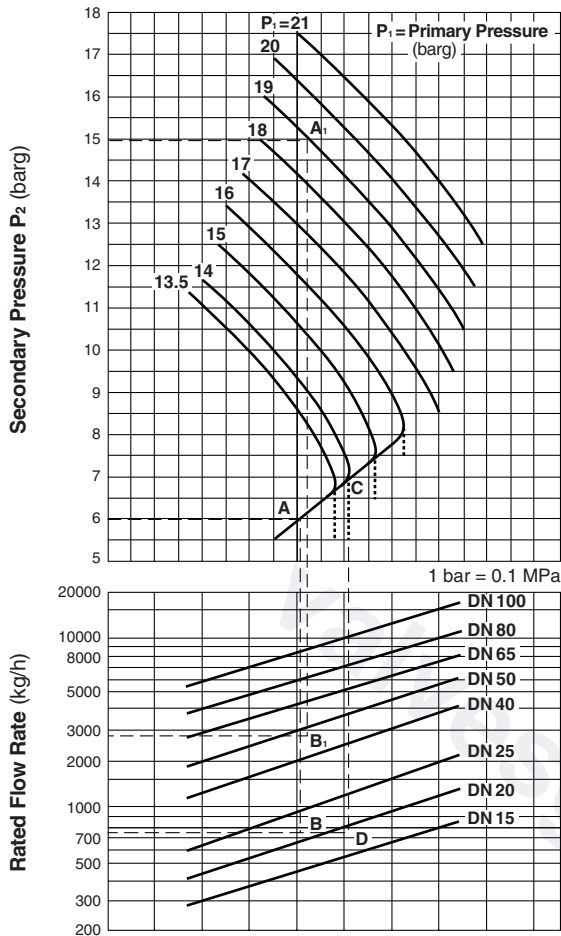

### Sizing Examples

#### For $P_1$ over 16 barg

For primary pressure of 19 barg, set pressure 15 barg, and saturated steam flow rate 2800 kg/h, select an appropriate size.

1. Locate intersecting point A<sub>1</sub> of 19 barg primary pressure and 15 barg set pressure. Go to point A<sub>1</sub> and down until 2800 kg/h, point B<sub>1</sub> is reached.
2. Since point B is located between DN 40 and DN 50, the larger size, DN 50, should be chosen.

#### Special Instructions for $P_1$ under 16 barg

The vertical dotted lines in the graph represent the increased capacity often achievable when the internal sensing features of COS-21 are enhanced by the installation of a 3/8 inch external secondary pressure-sensing line (condition:  $P_2 < \frac{1}{2} P_1$ ).

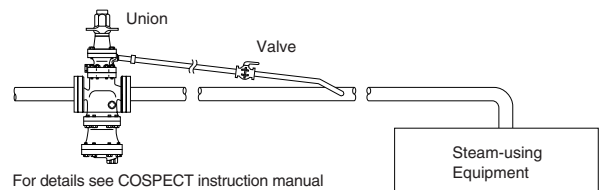

For details see COSPECT instruction manual

For primary pressure of 14 barg, set pressure 6 barg, and saturated steam flow rate 750 kg/h, select an appropriate size.

#### With internal secondary pressure-sensing channel

1. Locate intersecting point A of 14 barg primary pressure and 6 barg set pressure. Go to point A and down until 750 kg/h, point B, is reached.
2. Since point B is located between DN 20 and DN 25, the larger size, DN 25, should be chosen.

#### With external secondary pressure-sensing line

1. Obtain intersecting point C of 14 barg primary pressure. Go straight down from point C until 750 kg/h, point D, is reached.
2. Since point D is located between DN 15 and DN 20, the larger size, DN 20, should be chosen.

### Dimensions

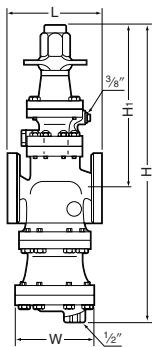

DN 15 - 50 shown. Configuration of larger sizes differs slightly.

#### COS-21 Flanged\* (mm)

DN	L			H	H <sub>1</sub>	W	Weight** (kg)
	DIN 2501	ASME Class					
	PN25/40	150RF	300RF				
(15)	150	161	167	515	305	105	15
(20)		172	178				
25	160	181	187	542	302	150	20
40	200	215	222	592	322	165	27
50	230	254	260	655	335	195	45
65	370	371	377	890	430	280	96
80	374	374	384				97
100	434	434	450	1048	468	350	159

( ) No ASME standard for ductile cast iron; machined to fit steel flanges

\* Flange to flange dimension of DN 15 and DN 65-100 not according to DIN standard, due to size of separator and steam trap.

\*\* Height and weight are for DIN PN 25/40. Other standards available, but length and weight may vary

### Trap Discharge Capacity

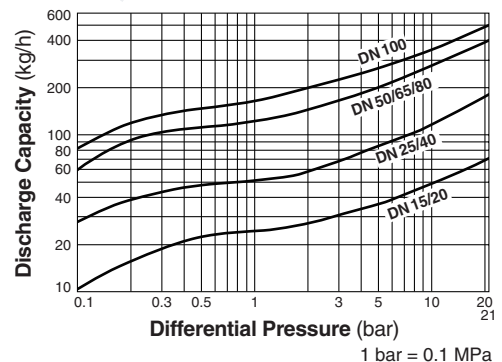

- Note:
1. The discharge capacity is the maximum continuous condensate discharge 6 °C below saturated steam temperature.
  2. The differential pressure is the difference between the COS-21 inlet and its trap outlet pressure.



DO NOT use this product under conditions that exceed maximum differential pressure, as condensate backup will occur!

**Option**

<p>Pressure Gauge Unit</p>	<p>Replaces the standard screen holder plug to enable installation of a pressure gauge of the user's choice.                  Primary side: M16 holder plug (male/female), BSP/Rc(PT)/NPT 3/8. An elbow is required for pressure gauge installation.                  Secondary side: Rc(PT) 3/8 mounting port for elbow and pressure gauge installation.</p> <p>Elbows, pressure gauge and connecting parts must be purchased separately.</p>
----------------------------	--

● **Configuration**

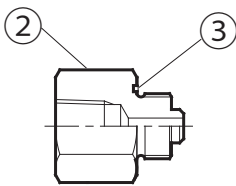

● **Installation Example**

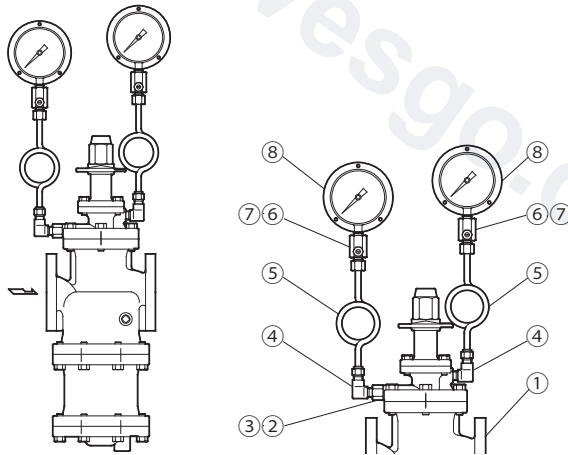

NOTE: For explanation purposes, a siphon tube style pressure gauge will be used. However, the instructions also apply to cooling tower-style pressure gauges.

No.	Part Name	No.	Part Name
1	Valve Body	5	Siphon Tube*
2	Holder Plug	6	Dampener*
3	Holder Plug Gasket	7	Dampener Gasket*
4	Elbow (male/female)*	8	Pressure Gauge*

\* Purchase separately

Manufacturer  
**TLV** CO., LTD.  
 Kakogawa, Japan  
is approved by LRQA Ltd. to ISO 9001/14001

