

MODEL 150L • 150F SIGHT GLASS

PRODUCT MANUAL

Thank you very much for choosing the Yoshitake's product. To ensure the correct and safe use of the product, please read this manual before use. This manual shall be kept with care for future references. The symbols used in this manual have the following meanings.



 Warning	This symbol indicates a potentially hazardous situation that, if not avoided, could result in death or serious injury.
 Caution	This symbol indicates a hazardous situation that, if not avoided, may result in minor or moderate injury or may result in only property damage.

Table of Contents

1. Overview	1
2. Features	1
3. Specifications	1
4. Dimensions and Weights	2
4.1 Screwed type	2
4.2 Flanged type	3
5. Scale Reading/Flow Rate Chart	4
6. Installation and Operation	5
6.1 Precaution for installation	5
6.2 Precaution for operation	5
7. Troubleshooting	6
8. Disassembly, Cleaning and Reassembly	6
8.1 Precaution for disassembly	6
8.2 Disassembly	7
8.3 Precaution for reassembly	7
8.4 Reassembly	7
9. Exploded Drawing	10
Warranty Information	

1. Overview

A sight glass is a device which permits the fluid flow inside the pipe to be checked visually, and can be widely used for equipment protection or process control in manufacturing facilities.

2. Features

1. Two component fluid can be checked by its color or mixed state. (150L)
2. Intermittent fluid flow can be checked. (150L)
3. Variation in flow rate can be checked easily by flap and scale plates. (150F)
4. Pressure loss caused by the fluid flow is as low as 0.01 MPa even when the flap shows the maximum flow rate, thus the product does not affect the fluid pressure. (150F)
5. The product can be connected to either horizontal or vertical piping.
6. The product can be used to steam condensate by being equipped with mica plates. (150□M-□□□)
7. The product comes in two different body materials, that is, ductile cast iron and cast stainless steel, meeting wider applications.

3. Specifications

Model	150L-F	150L-13S	150L-13F	150F-F	150F-13S	150F-13F
Type	Plain			Flap		
Application	Cold and hot water, Oil, Other non-dangerous fluids					
Nominal size	65A-150A	15A-50A	15A-100A	65A-150A	15A-50A	15A-100A
Max. working pressure	1.0 MPa					
Temperature range	5-150 °C					
Max. thermal shock	100 °C					
Material	Body	Ductile cast iron	Cast stainless steel (SCS13)	Ductile cast iron	Cast stainless steel (SCS13)	
	Glass	Hardened glass				
	Flap	-			Stainless steel	
Connection	JIS 10K FF flanged	JIS Rc screwed	JIS 10K FF flanged	JIS 10K FF flanged	JIS Rc screwed	JIS 10K FF flanged

- Available with the product with wetted parts made of SCS14 (as the 150□-14□).
- Available with the product with protective wire mesh (as the 150□P-□□□).
- When a flap type (15-50A) or a plain type is applied to steam condensate, use the product with mica plates (model number: 150□M-□□□), within max. working pressure of 0.6 MPa and max. temperature of 150 °C. Do not use a flap type of 65-150A for steam condensate application.



Caution

Please read this manual and confirm that the product specifications are sufficient for the service condition.

* If they are insufficient, please contact us without using the product.

4. Dimensions and Weights

4.1 Screwed type

[Example: 150F]

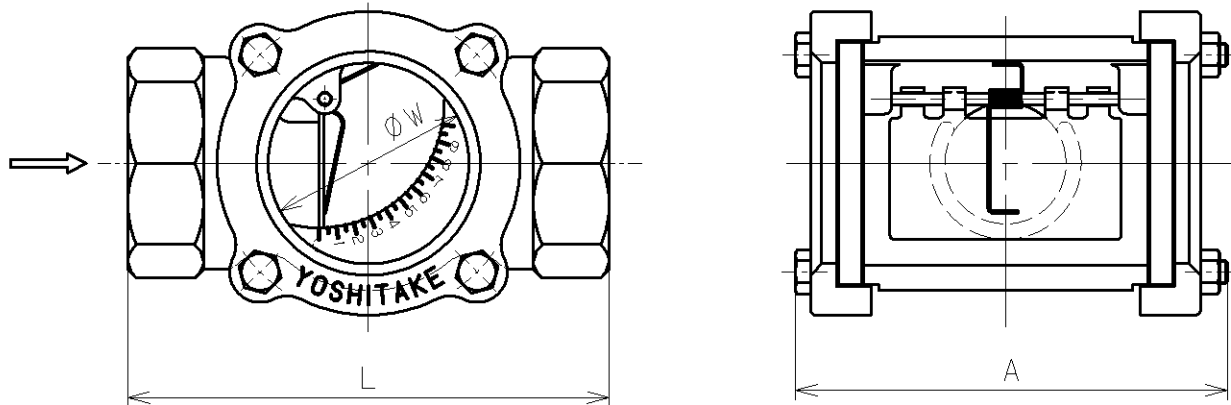

(mm)

Nominal size	L	A	W	Weight (kg)	
				150L-13S	150F-13S
15A	76	73.5	35	0.73	0.75
20A	89	73.5	35	0.82	0.84
25A	114	89	44	1.5	1.6
32A	127	114	53	2.3	2.4
40A	140	115.5	57	2.9	3.0
50A	162	147	73	5.8	5.9

- The products with protective wire mesh have dimensions A and weights different from the above.

4.2 Flanged type

[Example: 150F]

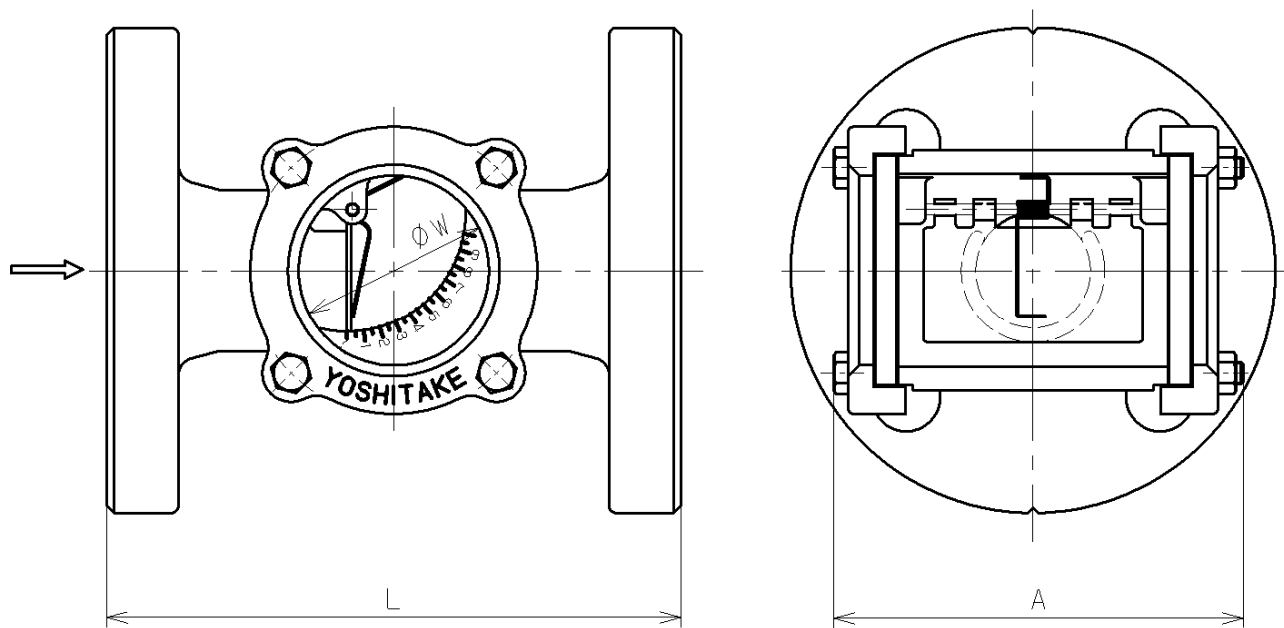

(mm)

Nominal size	L	A	W	Weight (kg)			
				150L-F	150L-13F	150F-F	150F-13F
15A	130	73.5	35	–	2.12	–	2.14
20A	130	73.5	35	–	2.47	–	2.49
25A	150	89	44	–	4.1	–	4.2
32A	160	114	53	–	5.4	–	5.5
40A	170	115.5	57	–	5.6	–	5.7
50A	200	147	73	–	9.7	–	9.8
65A	235	178	97	14.7	16.0	15.1	16.4
80A	235	188	97	15.1	16.5	15.5	16.9
100A	277	244	130	26.5	29.2	27.0	29.7
125A	336	248	155	36.8	–	37.3	–
150A	380	304	165	60.5	–	62.0	–

- The products with protective wire mesh have dimensions A and weights different from the above.

5. Scale Reading/Flow Rate Chart

Model: 150F
Fluid: Water

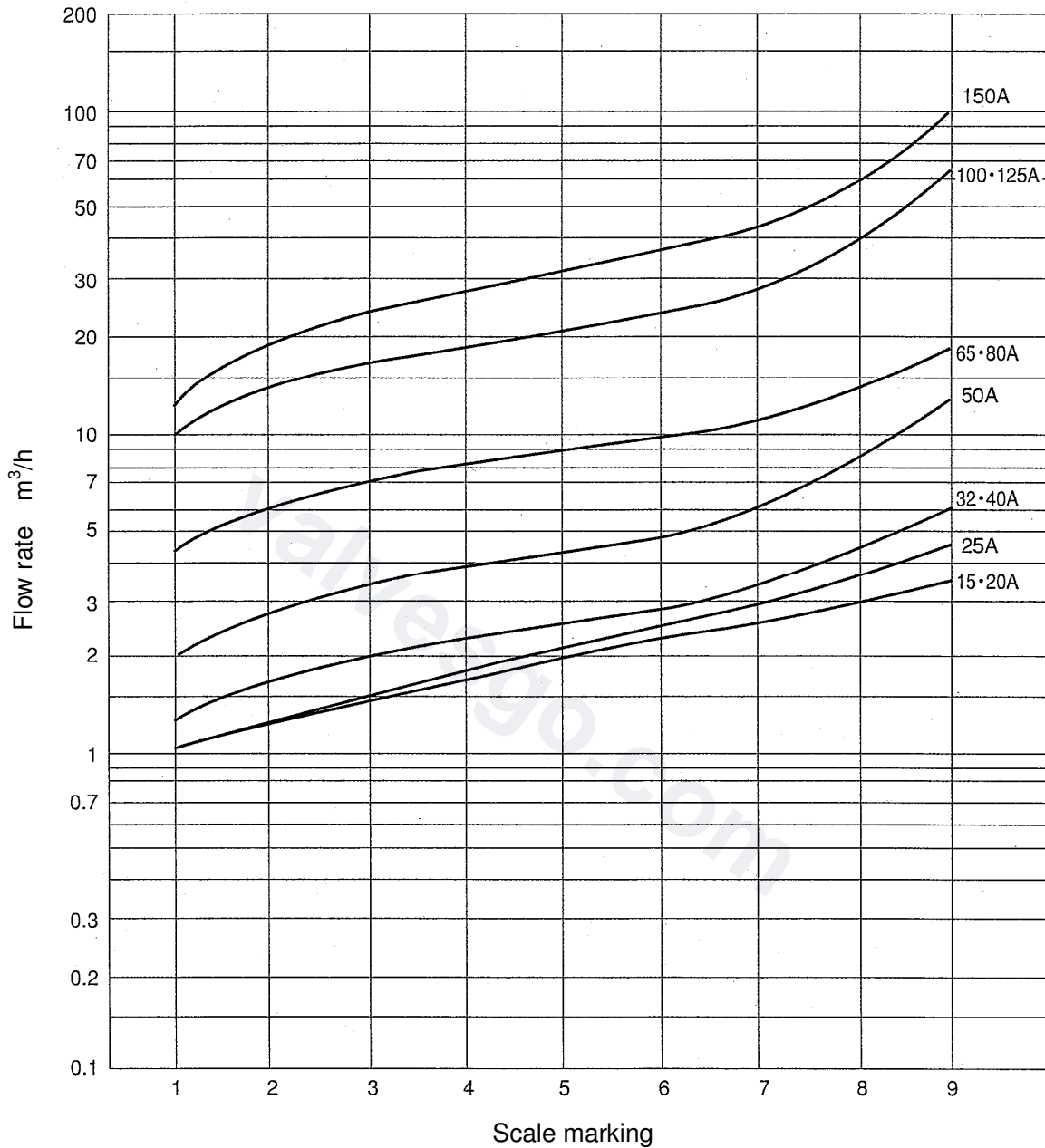

- The flow rates shown in the chart above are for reference only and cannot be used for actual measurement.

6. Installation and Operation

6.1 Precaution for installation



Caution

1. Before connecting the product to piping, confirm that the product specifications are sufficient for the service condition.
* Failure to follow this notice may prevent the product from functioning properly.
2. Before connecting the product to piping, remove foreign substances and dirt inside the piping.
* Failure to follow this notice may make the glass damaged due to scratches by foreign substances or may make the fluid cannot be seen through the glass due to glass opacity caused by scale/oil stains.
3. When installing, check the direction of the product so that the fluid flowing and the arrow marked on the product are in the same direction.
* Setting the product in wrong directions prevents the product from functioning properly.
4. For steam condensate application, make sure to use the product with mica plates to protect the glasses.
* Failure to follow this notice may result in erosion on the glass.
5. Do not apply excessive load, torque or vibration to the product.
* Failure to follow this notice may result in leakage.
6. Do not excessively screw in the product to the piping.
* Sealing material may reduce friction between the product and the piping. Screwing in the product excessively may damage the product.

6.2 Precaution for operation



Warning

1. Do not apply a rapid temperature change to the product during both initial and usual operations.
* A rapid temperature change may damage the glass resulting in a blowout of the fluid.
2. When the product is used for hot fluid, do not touch the product with bare hands.
* The product having hot fluid may scald your skin.
3. Do not retighten the cover of the product.
* Failure to follow this notice may damage the glass resulting in fluid blowout.



Caution

1. The glasses are consumable parts. Replace the glass if it is eroded by more than 10% of its thickness or if it has scratches or flaws.
* Failure to follow this notice may damage the glass.
2. The glasses may become opaque after contacting a certain type of fluid. If the glasses become opaque, replace them.

7. Troubleshooting

(See 8. Exploded Drawing on page 10 for each part)

Trouble	Cause	Remedy
Flap does not move. (For 150F)	1. The flap is caught by foreign substances sticking to the inner surface of the glass.	1. Disassemble and clean the product to remove the foreign substances. (See 8. Disassembly, Cleaning and Reassembly on pages 6 to 9.)
	2. The flap is caught by scratches on the inner surface of the glass.	2. Disassemble the product and replace the damaged parts. (See 8. Disassembly, Cleaning and Reassembly on pages 6 to 9.)
	3. Flow rate does not reach the min. limit.	3. Replace the product with the one of a nominal size that ensures a flow rate of the min. limit. (See 5. Scale Reading/Flow Rate Chart on page 4.)
	4. Fluid does not flow.	4. Check the piping.
	5. The product is installed in the opposite direction of the fluid flow.	5. Reinstall the product correctly. (Match the arrow mark on the body with the flow direction.)
Fluid flow cannot be observed.	1. Foreign substances stick to the inner surface of the glass, or the glass is stained.	1. Disassemble and clean the product to remove the foreign substances. (See 8. Disassembly, Cleaning and Reassembly on pages 6 to 9.)
	2. The inner surface of the glass has erosion or scratches.	2. Disassemble the product and replace the glass. (See 8. Disassembly, Cleaning and Reassembly on pages 6 to 9.)
Outside leakage	1. The gasket leaks.	1. Disassemble the product and replace the gasket. (See 8. Disassembly, Cleaning and Reassembly on pages 6 to 9.)
	2. The glass is damaged.	2. Disassemble the product and replace the glass. (See 8. Disassembly, Cleaning and Reassembly on pages 6 to 9.)

8. Disassembly, Cleaning and Reassembly

8.1 Precaution for disassembly

	<p>Warning</p> <p>Completely discharge the pressure inside of the product, piping and equipment prior to disassembly and inspection. When fluid is hot, cool down the product to the condition that it can be touched with bare hands. * Failure to follow this notice may result in injury due to the residual pressure, and may result in scalds due to high temperature in the case of hot fluid.</p>
---	---

8.2 Disassembly

- 150L, 150LM
 1. Completely discharge the pressure inside of the product.
Remove the bolts and nuts.
Take out the covers and glasses.
If the glass sticks to the body and hardly comes off, put the cover on the glass in a way that the outer circumference of the glass fits the inner circumference of the cover, and then tap the cover on its outer side.
* For 150LM, mica plates are included.
- 150F, 150FM
 1. Completely discharge the pressure inside of the product.
Remove the bolts and nuts.
Take out the covers and glasses.
If the glass sticks to the body and hardly comes off, put the cover on the glass in a way that the outer circumference of the glass fits the inner circumference of the cover, and then tap the cover on its outer side.
* For 150FM, mica plates are included.

8.3 Precaution for reassembly



Caution

1. Clean the gasket spaces of the body, covers and glasses.
* Failure to follow this notice may cause outside leakage at the gasket resulting in scalds or injury.
2. The glasses are consumable parts. Replace the glass if it is eroded by more than 10% of its thickness or if it has scratches or flaws.
* Failure to follow this notice may cause outside leakage resulting in scalds or injury.
3. The gaskets are consumable parts. Replace them with new ones at the time of reassembly of the product.
* Failure to follow this notice may cause outside leakage resulting in scalds or injury.

8.4 Reassembly

- 150L
 1. Attach the gaskets, glasses, and gaskets in this order to the covers and assemble them to the body.
 2. To fix the covers to the body, firstly tighten them temporarily with bolts and nuts, and then tighten them evenly at the torque specified in Table 1 by using a torque wrench.
* Overtightening damages the glass.
- 150F
 1. Attach the scale plates, glasses, and gaskets in this order to the covers and assemble them to the body.
* Attach the scale plates in positions where they can be read from outside of the product. In addition, make the flap point at the minimum scale value. (See picture 1.)



Picture 1

2. To fix the covers to the body, firstly tighten them temporarily with bolts and nuts, and then tighten them evenly at the torque specified in Table 1 by using a torque wrench.
- * Overtightening damages the glass.

Table 1 Tightening torque

Nominal size	Tightening torque
15A, 20A	7 N·m
25A, 32A	10 N·m
40A	15 N·m
50A	25 N·m
65A-125A	29.4 N·m
150A	68.6 N·m

- 150LM, 150FM

Glasses and mica plates are not bonded. Please be careful when handling.

[150LM]

1. Attach the gaskets, glasses, mica plates, and gaskets in this order to the covers.

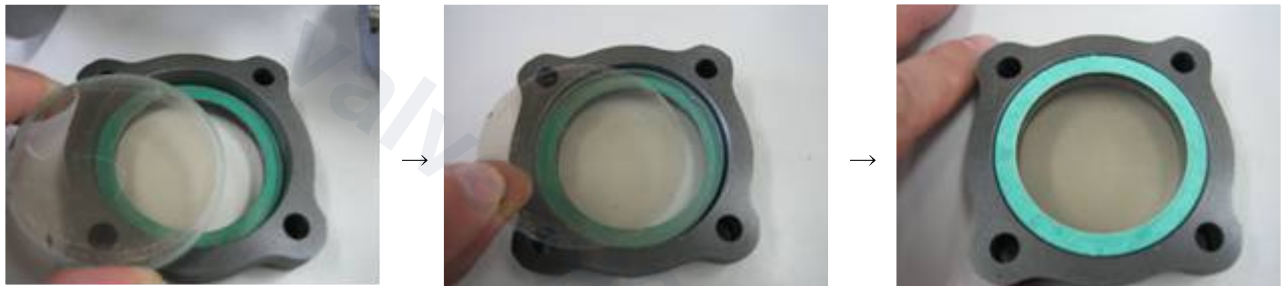

[150FM]

2. Attach the gaskets to the body. (See Picture 2.)
- * Attach the gasket in a manner that the end of spindle is covered by the triangular part of the gasket. (See Pictures 4 and 5.)



Picture 2

- Attach the scale plates, glasses, and mica plates in this order to the covers. (See Picture 3.)



Picture 3

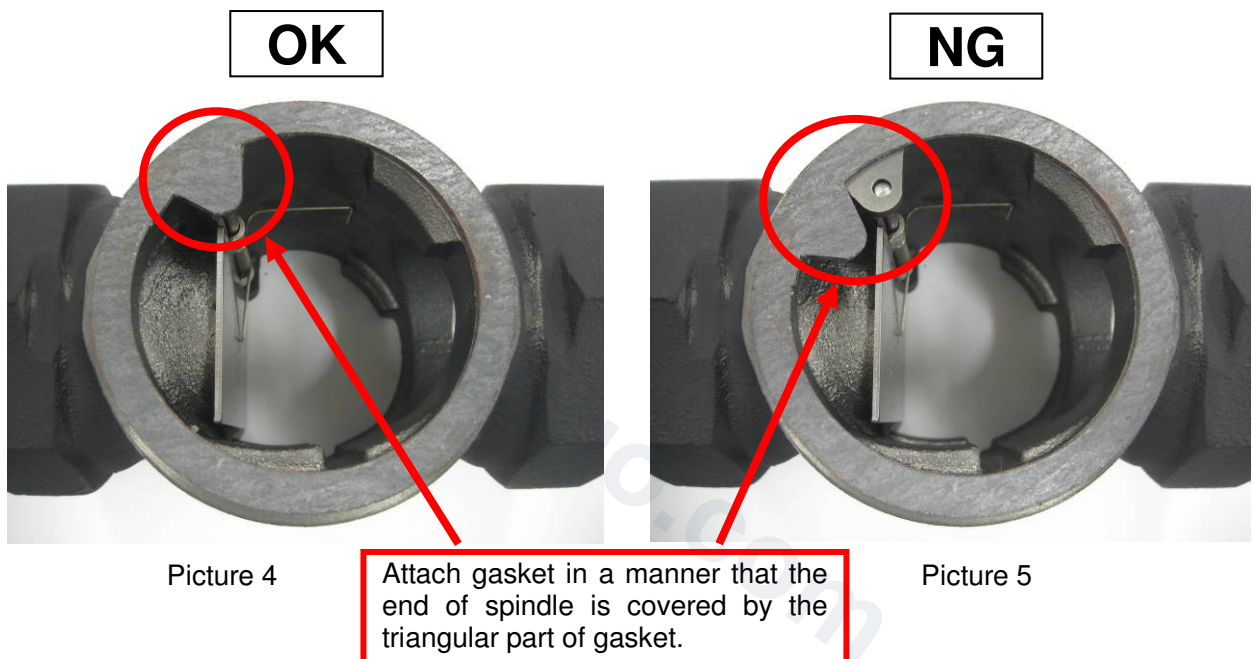

Picture 4

Picture 5

3. To fix the covers to the body, firstly tighten them temporarily with the bolts and nuts, and then tighten them evenly at the torque specified in Table 1 by using a torque wrench. (See picture 6.)
 - * Overtightening damages the mica plate and the glass.
 - * Attach the scale plates in positions where they can be read from outside of the product. In addition, make the flap point at the minimum scale value. (See picture 7.)



Picture 6



Picture 7

9. Exploded Drawing

Model: 150F

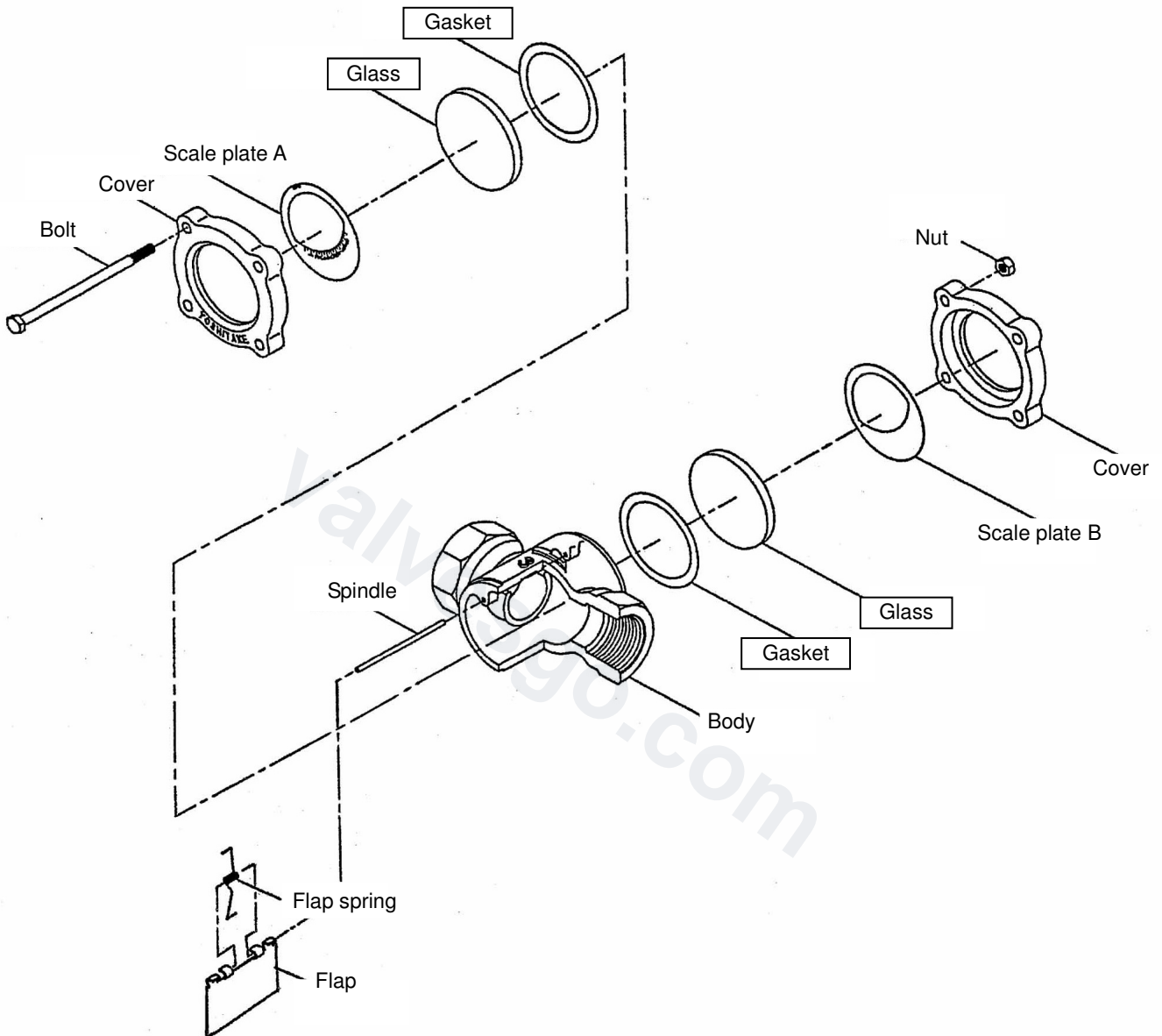

The parts shown in the rectangle boxes are available as consumables.

- 150L (plain type) has no flap assembly (flap, flap spring, and spindle) and it has two more gaskets instead of scale plates (A and B).
- Optional mica plates are attached to body sides of the glasses. (150□M-□□□)
- The product with protective wire mesh has covers of different structure. (150LP and 150FP)