

MODEL AL-150 series and AL-140 series SAFETY RELIEF VALVE

PRODUCT MANUAL

Thank you very much for choosing the Yoshitake's product. To ensure the correct and safe use of the product, please read this manual before use. This manual shall be kept with care for future references.

The symbols used in this manual have the following meanings.



 Warning	This symbol indicates a potentially hazardous situation that, if not avoided, could result in death or serious injury.
 Caution	This symbol indicates a hazardous situation that, if not avoided, may result in minor or moderate injury or may result in only property damage.

Table of Contents

1. Usage of the Product	1
2. Specifications	1
3. Dimensions and Weight	2
4. Structure	3
5. Operation	4
6. Nominal Size Selection Table	4
6.1 For steam (at saturated temperature)	4
6.2 For air (at 20°C)	5
6.3 For water (accumulation: 25%)	6
7. Installation	7
7.1 Piping example	8
8. Maintenance	8
8.1 Daily inspection	9
8.2 Monthly inspection	9
8.3 Troubleshooting	9
Warranty Information	

YOSHITAKE

1. Usage of the Product

The AL-150 series and the AL-140 series safety relief valves are used mainly in various pressure vessels, instrumentation devices and at outlet of pressure reducing valves to prevent accidents caused by abnormal pressure rise.

2. Specifications

Model	AL-150	AL-150H	AL-140	AL-140H	AL-150L	AL-140ML
Structure	Closed type *1				Open type with lever *2	Closed type with lever *1
Application	Steam, Air, Cold and hot water, Oil, Other non-dangerous fluids				Steam, Air	Air, Cold and hot water, Oil, Other non-dangerous fluids
Working pressure	0.05-1.0 MPa	1.0-1.6 MPa	0.05-1.0 MPa	1.0-2.0 MPa	0.05-1.0 MPa	
Working temperature	5-220°C *3					5-120°C
Connection	JIS Rc screwed					
Nominal size	15-50A					
Material	Spring case	Cast bronze		Cast stainless steel	Cast bronze	Cast stainless steel
	Valve, valve seat	Stainless steel				
	Spring	Stainless steel	Alloy steel	Stainless steel		

*1: The structure in which the fluid is discharged only from the outlet.

*2: The structure in which the fluid is discharged from the outlet and other parts.

*3: The maximum temperature is 150°C when the fluid is liquid.

Warning

1. Do not apply the product to devices which do not allow any valve seat leakage.
* The product has allowable valve seat leakage and does not close completely (valve seat leakage cannot be zero).
2. Do not use the product for equipment or device which vibrates excessively.
* Failure to follow this notice may result in malfunction.
3. Do not adjust or change the set pressure.
* Failure to follow this notice may result in damage to the equipment.



Caution

Please confirm that the indications on the product correspond with the specifications of the ordered product model before use.

* If they are different, do not use the product and contact us.

3. Dimensions and Weight

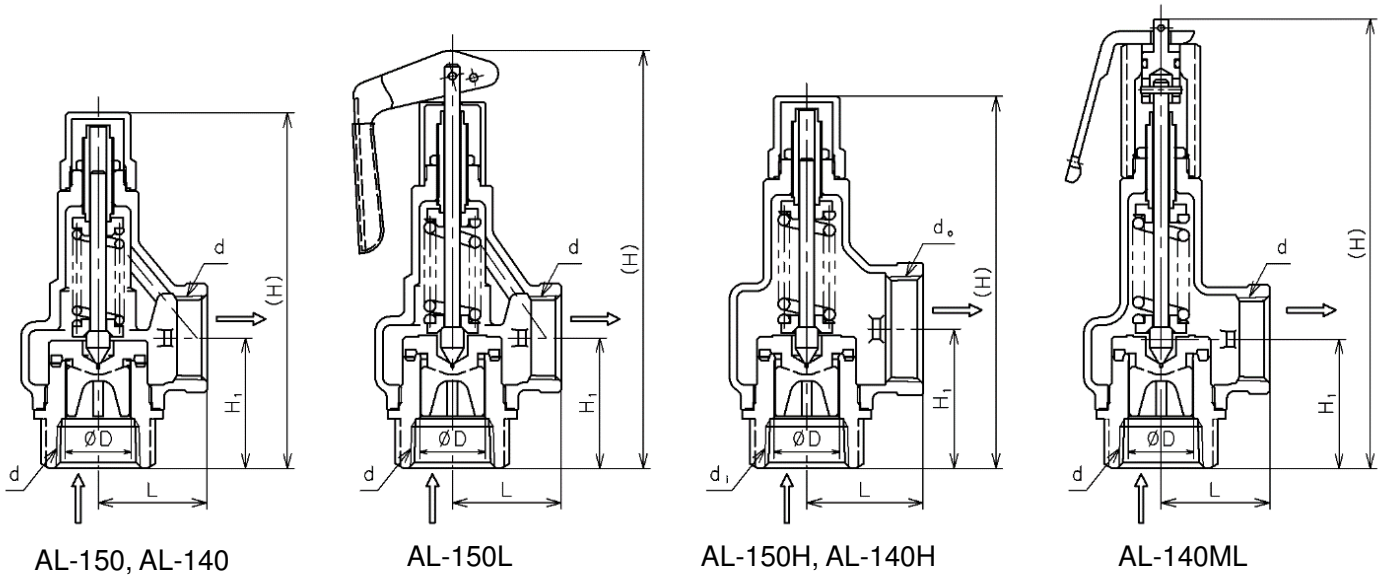

Fig.1 Dimensions

■ AL-150, 150L

Nominal size	Blowout area [mm ²]	Dimensions [mm]						Weight [kg]	
		d	D	L	H ₁	H		AL-150	AL-150L
						AL-150	AL-150L		
15A	20.1	Rc 1/2	16	34	40	128	148	0.7	0.8
20A	34.6	Rc 3/4	21	38	43	128.5	148	0.8	0.9
25A	53.0	Rc 1	26	43	51.5	144.5	165	1.1	1.2
32A	93.3	Rc 1 1/4	33	50	61.5	181.5	201	1.8	1.9
40A	135.2	Rc 1 1/2	41	60	60	205	226	2.8	2.9
50A	208.2	Rc 2	51	75	76	245.5	266	4.7	4.8

■ AL-140, 140ML

Nominal size	Blowout area [mm ²]	Dimensions [mm]						Weight [kg]	
		d	D	L	H ₁	H		AL-140	AL-140ML
						AL-140	AL-140ML		
15A	20.1	Rc 1/2	16	34	40	128	157	0.7	0.8
20A	34.6	Rc 3/4	21	38	42	129	158	0.8	0.9
25A	53.0	Rc 1	26	43	51	148	174	1.1	1.3
32A	93.3	Rc 1 1/4	33	50	61.5	182	212	1.8	1.9
40A	135.2	Rc 1 1/2	41	60	64	206	246	2.8	3.0
50A	208.2	Rc 2	51	75	76	246.5	286	4.7	4.9

■ AL-150H, 140H

Nominal size	Blowout area [mm ²]		Dimensions [mm]						Weight [kg]		
			di × do	D	L	H ₁		H			
	AL-140H	AL-150H				AL-140H	AL-150H	AL-140H	AL-150H	AL-140H	AL-150H
15A	20.1	22.9	Rc 1/2 × Rc 3/4	16	36	42	42	126.5	126	0.9	0.8
20A	34.6	39.5	Rc 3/4 × Rc 1	21	38	46	47	130.5	131	1.0	0.9
25A	53.0	60.6	Rc 1 × Rc 1 1/4	26	46	55	55.5	150.5	147.5	1.5	1.3
32A	93.3	97.7	Rc 1 1/4 × Rc 1 1/2	33	54	61.5	61.5	195	167.5	2.5	1.9
40A	135.2	150.8	Rc 1 1/2 × Rc 2	41	63	67	67	227.5	193.5	4.6	2.9
50A	208.2	233.4	Rc 2 × Rc 2 1/2	51	77	80	80	303.5	241.5	8.8	5.0

4. Structure

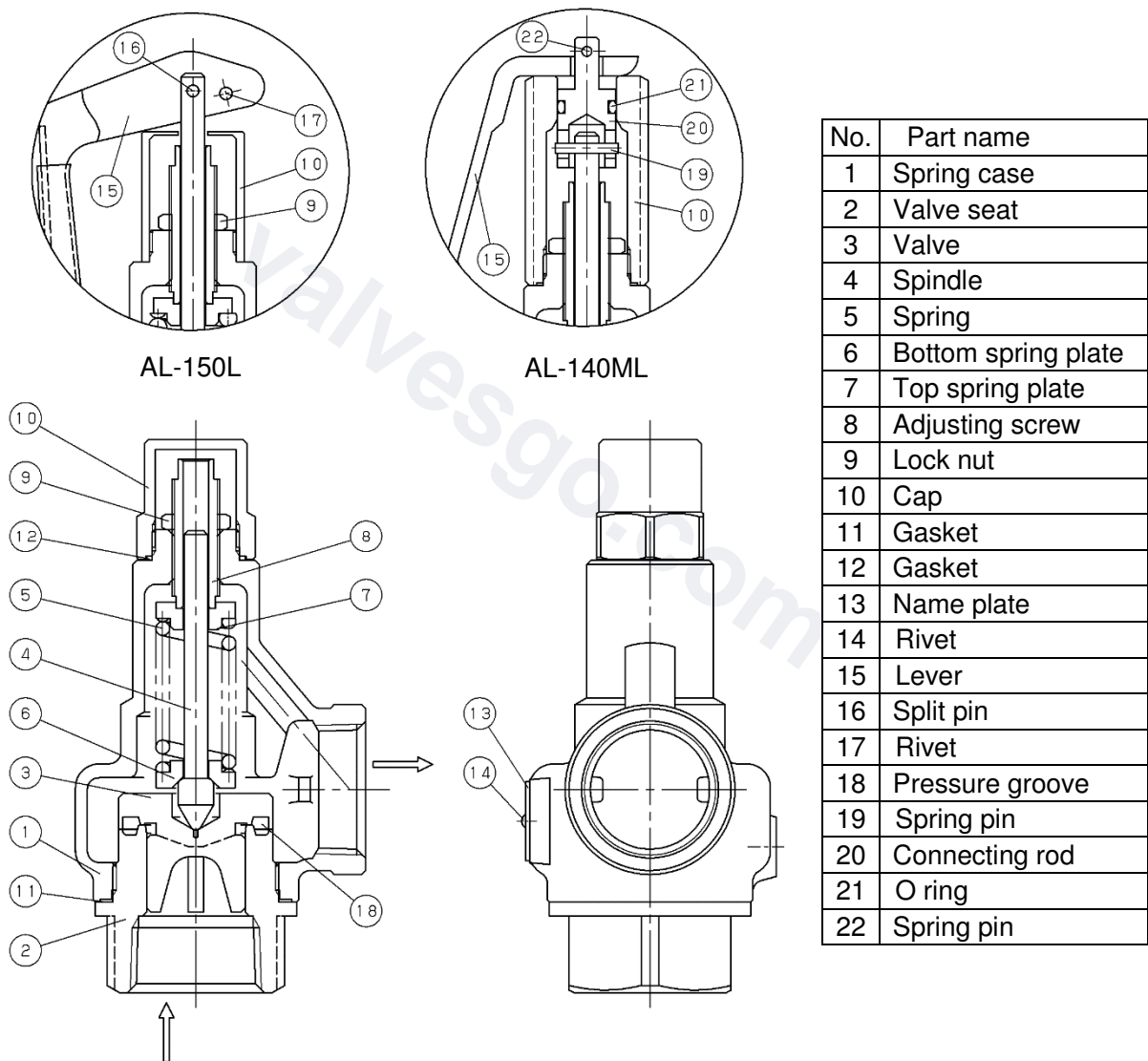

Fig.2 Structure

5. Operation

■ Blowout operation

As the inlet pressure approaches the blowout pressure, the force of fluid pushing up the valve [3] approaches the force of the spring [5] pressing down the valve [3]. The safety relief valve commences to blow when the inlet pressure reaches around 3% below the blowout pressure.

The fluid accumulates gradually on the pressure groove [18] and when the fluid pressure reaches the blowout pressure the valve [3] pops.

■ Closing operation

Since the inlet pressure of the safety relief valve decreases when the fluid is released into the atmosphere by the pop action of valve [3], the force of fluid lift is lowered. At this point, the repelling force of the spring [5] becomes larger than the force of fluid lift and thus the valve closes. In addition, while the safety relief valve discharges, pressure of fluid entering into the back of the valve [3] (back pressure) adds to the closing force.

6. Nominal Size Selection Table

6.1 For steam (at saturated temperature)

6.1.1 AL-150, AL-140 and AL-150L

Capacity <Pressure vessel structure standard>

[kg/h]

Nominal size	Blowout area [mm ²]	Set pressure [MPa]										
		0.05	0.1	0.2	0.3	0.4	0.5	0.6	0.7	0.8	0.9	1.0
15A	20.1	15	20	29	40	50	60	70	80	90	100	109
20A	34.6	27	35	51	69	87	104	121	138	155	172	189
25A	53.0	42	54	78	105	133	159	186	212	237	263	289
32A	93.3	70	91	132	178	224	268	313	356	400	443	487
40A	135.2	105	136	198	266	335	402	468	534	599	664	729
50A	208.2	163	211	306	411	518	621	723	824	924	1025	1126

6.1.2 AL-140H

Capacity <Pressure vessel structure standard>

[kg/h]

Nominal size	Blowout area [mm ²]	Set pressure [MPa]										
		1.0	1.1	1.2	1.3	1.4	1.5	1.6	1.7	1.8	1.9	2.0
15A	20.1	109	119	129	139	149	158	168	178	188	198	207
20A	34.6	189	206	222	239	256	273	290	306	324	340	357
25A	53.0	289	315	341	367	393	418	444	470	496	522	547
32A	93.3	487	531	574	617	661	704	747	791	835	878	921
40A	135.2	729	795	860	924	990	1054	1119	1184	1250	1315	1380
50A	208.2	1126	1227	1327	1427	1528	1627	1728	1828	1930	2030	2130

6.1.3 AL-150H

Capacity <Pressure vessel structure standard>

[kg/h]

Nominal size	Blowout area [mm ²]	Set pressure [MPa]						
		1.0	1.1	1.2	1.3	1.4	1.5	1.6
15A	22.9	115	126	136	146	156	167	177
20A	39.5	199	217	235	252	270	288	306
25A	60.6	306	333	360	387	415	442	469
32A	97.7	493	537	581	625	669	713	757
40A	150.8	761	830	897	965	1033	1100	1168
50A	233.4	1179	1284	1389	1494	1599	1703	1808

6.2 For air (at 20°C)

6.2.1 AL-150, AL-140, AL-140ML and AL-150L

Capacity <Pressure vessel structure standard>

[kg/h]

Nominal size	Blowout area [mm ²]	Set pressure [MPa]										
		0.05	0.1	0.2	0.3	0.4	0.5	0.6	0.7	0.8	0.9	1.0
15A	20.1	25	33	48	65	81	98	114	131	147	164	181
20A	34.6	44	57	83	111	140	169	197	226	254	283	311
25A	53.0	67	87	127	171	215	258	302	346	390	433	477
32A	93.3	113	147	214	288	362	435	509	582	656	730	803
40A	135.2	169	221	321	431	542	652	762	872	982	1093	1203
50A	208.2	262	341	496	666	836	1006	1176	1346	1516	1687	1857

6.2.2 AL-140H

Capacity <Pressure vessel structure standard>

[kg/h]

Nominal size	Blowout area [mm ²]	Set pressure [MPa]										
		1.0	1.1	1.2	1.3	1.4	1.5	1.6	1.7	1.8	1.9	2.0
15A	20.1	181	197	214	230	247	264	280	297	313	330	347
20A	34.6	311	340	368	397	426	454	483	511	540	568	597
25A	53.0	477	521	565	608	652	696	740	783	827	871	915
32A	93.3	803	877	950	1024	1098	1171	1245	1318	1392	1466	1539
40A	135.2	1203	1313	1423	1533	1644	1754	1864	1974	2084	2195	2305
50A	208.2	1857	2027	2197	2367	2537	2707	2877	3047	3217	3388	3558

6.2.3 AL-150H

Capacity <Pressure vessel structure standard>

[kg/h]

Nominal size	Blowout area [mm ²]	Set pressure [MPa]						
		1.0	1.1	1.2	1.3	1.4	1.5	1.6
15A	22.9	190	208	225	243	260	278	295
20A	39.5	328	359	389	419	449	479	509
25A	60.6	504	550	597	643	689	735	782
32A	97.7	813	888	962	1037	1111	1186	1260
40A	150.8	1255	1370	1485	1600	1715	1831	1946
50A	233.4	1943	2121	2299	2477	2655	2833	3011

6.3 For water (accumulation: 25% *1)

6.3.1 AL-150, AL-140 and AL-140ML

Capacity <Yoshitake standard>

[m³/h]

Nominal size	Blowout area [mm ²]	Set pressure [MPa]										
		0.05	0.1	0.2	0.3	0.4	0.5	0.6	0.7	0.8	0.9	1.0
15A	20.1	0.4	0.5	0.9	1.1	1.3	1.5	1.6	1.8	1.9	2.0	2.1
20A	34.6	0.6	0.9	1.6	2.0	2.3	2.6	2.8	3.1	3.3	3.5	3.7
25A	53.0	1.0	1.5	2.5	3.1	3.6	4.0	4.4	4.7	5.1	5.4	5.7
32A	93.3	1.8	2.6	4.5	5.5	6.3	7.1	7.8	8.4	9.0	9.5	10.0
40A	135.2	2.7	3.8	6.5	7.9	9.2	10.3	11.3	12.2	13.0	13.8	14.6
50A	208.2	4.1	5.9	10.0	12.3	14.2	15.9	17.4	18.8	20.1	21.3	22.4

6.3.2 AL-140H

Capacity <Yoshitake standard>

[m³/h]

Nominal size	Blowout area [mm ²]	Set pressure [MPa]										
		1.0	1.1	1.2	1.3	1.4	1.5	1.6	1.7	1.8	1.9	2.0
15A	20.1	2.1	2.2	2.3	2.4	2.5	2.6	2.7	2.8	2.9	2.9	3.0
20A	34.6	3.7	3.9	4.0	4.2	4.4	4.5	4.7	4.8	5.0	5.1	5.2
25A	53.0	5.7	6.0	6.2	6.5	6.7	7.0	7.2	7.4	7.6	7.8	8.0
32A	93.3	10.0	10.5	11.0	11.4	11.9	12.3	12.7	13.1	13.5	13.8	14.2
40A	135.2	14.6	15.3	15.9	16.6	17.2	17.8	18.4	19.0	19.5	20.1	20.6
50A	208.2	22.4	23.5	24.6	25.6	26.6	27.5	28.4	29.3	30.1	30.9	31.8

6.3.3 AL-150H

Capacity <Yoshitake standard>

[m³/h]

Nominal size	Blowout area [mm ²]	Set pressure [MPa]						
		1.0	1.1	1.2	1.3	1.4	1.5	1.6
15A	22.9	2.4	2.5	2.7	2.8	2.9	3.0	3.1
20A	39.5	4.2	4.4	4.6	4.8	5.0	5.2	5.3
25A	60.6	6.5	6.8	7.1	7.4	7.7	8.0	8.2
32A	97.7	10.5	11.0	11.5	12.0	12.4	12.9	13.3
40A	150.8	16.2	17.0	17.8	18.5	19.2	19.9	20.6
50A	233.4	25.2	26.4	27.6	28.7	29.8	30.8	31.8

*1: [Example] When the set pressure of 1.0 MPa, and the valve size is 50A

The capacity of AL-150, AL-140, AL-140ML and AL-140H is 22.4 m³/h, and that of AL-150H is 25.2 m³/h, when the inlet pressure reaches 1.25 MPa (accumulation becomes 25%) after the fluid pressure reaches the set pressure of 1.0 MPa.

7. Installation

Warning

1. Do not install any closing device such as a stop valve at inlet or outlet sides of the product.
* Failure to follow this notice may result in damage to the pressure vessel because such closing device may hamper the blowout of the safety relief valve.
2. Install an exhaust pipe on outlet side of the product, and lead it to a place where there is no risk of physical damage even if fluid blows out.
* Failure to follow this notice may result in injury and scalds in case of fluid blow out.
3. Do not disassemble the product.
* Failure to follow this notice may prevent the product from functioning properly and lead to danger.
4. When installing, tighten the hexagonal part of the valve seat [2] with a spanner.
Do not adjust its direction by rotating the outlet piping.
* Failure to follow this notice may result in scalds or injury due to blow-off caused by screw crack on the spring case [1] or losing of the spring case [1] and the valve seat [2].
5. Do not apply viscous fluid that may make fixation of the valve and valve seat.
* Failure to follow this notice may prevent the product from functioning properly.

Caution

1. Before installing the product, remove foreign substances and scale from the piping.
* Failure to follow this notice may prevent the product from functioning properly.
Note that the customer will be required to pay repair charge for any defect that occurs due to foreign substances.
2. When installing the product, match the direction of fluid flow with the inlet and outlet of the product respectively.
* Failure to follow this notice may prevent the product from functioning properly.
3. Install the product vertically with the cap [10] facing upward.
* Failure to follow this notice may prevent the product from functioning properly.
4. Securely support and fasten the pipes.
Refer to the following "Pipe mount" and "Exhaust pipe".
* If an excessive stress is applied to the piping, the product may be deformed and not open/close.
5. Lead exhaust pipe to outside of buildings if there is a risk that fluid blowout causes alarm activation or contamination of the peripheral equipment.
* Improper placement may cause contamination of the peripheral equipment.
6. Connect the product to the pipes securely.
* Improper connecting may cause fluid leakage from the piping joint when vibration is applied, or may cause scalds in case that fluid is hot.
7. If there is a risk that condensate or rain water accumulates in exhaust pipe, attach drain pipe with the product and/or the exhaust pipe in a position where they can be drained.
* Failure to follow this notice may cause rust and result in malfunction.
8. Inner diameters of pipe mount and of exhaust pipe shall be more than those of each inlet and outlet of the product.
* Failure to follow this notice may result in malfunction or insufficient amount of blowout.
9. Secure enough space required for maintenance or inspections.
* Failure to follow this notice prevents maintenance and inspections being implemented.
10. Avoid rapid pressure change. Impact by a rapid pressure change, such as water hammer, may damage the product/parts.
11. Do not apply excessive load, torque or vibration to the product.
12. Select a proper model according to usage conditions including operation frequency and durability required.

■ Cleaning the inside of the piping

1. Please clean the inside of the pipe thoroughly and remove any dust or scales before installing the product. **Please note that all repairs for disorders due to foreign substances shall be charged.**

■ Pipe mount

1. Pipe mount should have sufficient strength and rigidity against stress which are induced by reaction force in opposite direction of the exhaust through the axis of the exhaust pipe.
2. Pressure loss in pipe mount leads to decrease in the discharge volume and to unstable operation of the product. To prevent this from happening, install the product vertically as close as possible to the can body and the header. In addition, place the product in a position where maintenance and inspection can be done easily.
3. Inner diameter of pipe mount shall be more than that of the product inlet.

■ Exhaust pipe

1. Install exhaust pipe and drip pan elbow so that the product can not be subject to the stress caused by thermal expansion of equipment and by dilatation of the exhaust pipe due to thermal action of blowout.
2. Inner diameter of exhaust pipe shall be more than that of the product outlet to avoid improper back pressure.

7.1 Piping example

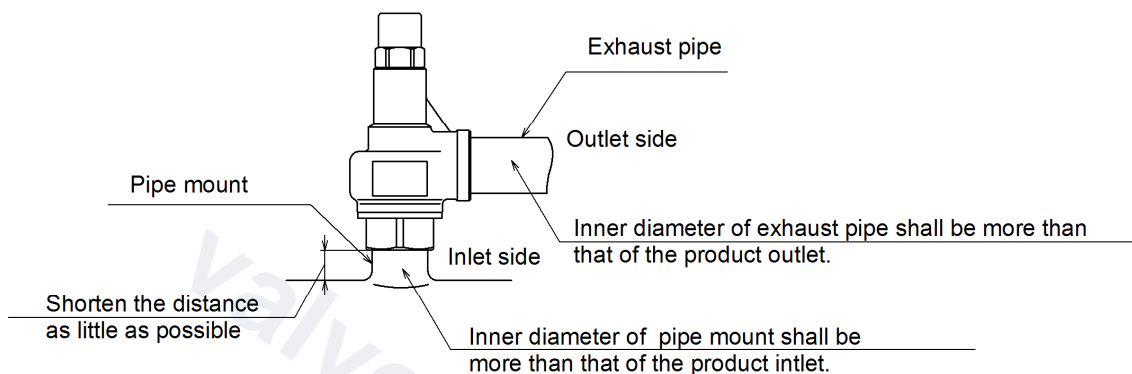

Fig.3 Piping example

8. Maintenance

⚠ Warning

1. Do not touch the product/pipes or the lever [15] with bare hands.
* Failure to follow this notice may result in scalds or injury in case that fluid is hot.
2. Do not touch the product unless it is necessary.
* Failure to follow this notice may result in scalds or injury in case that fluid is hot.
3. When checking the operation of the product, wear earplugs and stand clear of exhaust pipe end during inspection. Do not look down or touch the open end of the exhaust pipe.
* Failure to follow this notice may result in scalds or injury due to blow-off. Be aware that the product makes a loud noise at start-up.
4. Do not remove the cap [10].
* Failure to follow this notice may cause danger due to blow-off from the adjusting screw.
5. Do not disassemble the product.
* Please contact us if any abnormal condition is observed.

⚠ Caution

1. Before applying higher pressure fluid to the product, check that no problems have occurred in the equipments on the piping.
* Failure to follow this notice may damage the equipment.
2. Completely discharge fluid from the product and piping before leaving the product not operated for a long time.
* Failure to follow this notice may cause foreign substances and scale inside of the piping and may result in malfunction of the product.
3. If the product is not operated for a long time, perform test working before starting operation.

8.1 Daily inspection

Check the following items while the system is in operation.

- Corrosion or crack on the product
- Leakage from the product under normal working pressure (check it visually and aurally).
- Leakage from joints between the product and piping.

* Please contact us if any abnormal condition is observed.

8.2 Monthly inspection

1. Check that there is no loose piping at inlet and outlet side of the product. In addition, check that the cap [10] is fastened securely. (For the AL-150L, the normal state is that the cap [10] fits loosely and can be rotated by hand.)
2. Check the operation of the product by raising fluid pressure to the set pressure.
For the AL-150L (open type with a lever), check that, by lifting up the lever, fluid blows out at a pressure of 75% or more of the set pressure.
For the AL-140ML (closed type with a lever), check the operation, by lifting up the lever, while differential pressure between the set and inlet pressures is within the range of Table 1.
* Please contact us if any abnormal condition is observed.

Table 1. The differential Pressure in which the blow-off inspection by lever operation is possible

Size	Differential pressure between set and inlet pressures
15-25A	1.0 MPa or less
32-40A	0.6 MPa or less
50A	0.4 MPa or less

8.3 Troubleshooting

Trouble	Cause	Remedy
Leakage detected visually/aurally at the outlet *	1. Foreign substance or scale stuck on contact surface between the valve [3] and valve seat [2].	1. Follow the procedure described in 8.2.2. to operate the product and eliminate the foreign substance and scale. Please contact us if the trouble does not stop.
	2. Damage on contact surfaces of the valve [3] and valve seat [2].	2. The product needs to be disassembled and its parts need to be replaced. Please contact us.
	3. Excessive vibration applied to the piping where the product is installed.	3. The product should not be used on device or equipment that vibrates excessively.
	4. The pressure difference between the set pressure and the normal working pressure is too small.	4. Increase the pressure difference. If the set pressure needs to be readjusted, please contact us.
	5. The pressure momentarily exceeds the set pressure because of fluid pulsation.	5. In view of fluid pulsation, the set pressure needs to be raised (readjusted) or the normal working pressure needs to be lowered. To raise (readjust) the set pressure, please contact us.
	6. Fluid flows into the outlet piping.	6. Change the piping layout to keep the fluid from flowing into the outlet piping.
Blows at a pressure lower than the set pressure.	1. The product specifications are not consistent with the use condition.	1. Check the set pressure indication on the name plate. If the product is not suitable for the usage condition, replace it with a proper one.
	2. The pressure gauge is out of order.	2. Calibrate the pressure gauge or replace it with a new one.
	3. The product does not keep the accuracy of its set pressure.	3. The set pressure needs to be readjusted. Please contact us.

* The product has allowable valve seat leakage and does not close completely (valve seat leakage cannot be zero).

Trouble	Cause	Remedy
Does not operate at the set pressure.	1. The product specifications are not consistent with the use condition.	1. Check the set pressure indication on the name plate. If the product is not suitable for the usage condition, replace it with a proper one.
	2. The pressure gauge is out of order.	2. Calibrate the pressure gauge or replace it with a new one.
	3. Sliding parts of the valve [3] and valve seat [2] do not move smoothly.	3. The product needs to be disassembled and cleaned. Please contact us for repair.
	4. There is a back pressure at the piping of the product outlet.	4. Remove the back pressure. Change the piping layout not to allow the back pressure exist.
	5. The product does not keep the accuracy of its set pressure.	5. The set pressure needs to be readjusted. Please contact us.
Does not stop blowing.	1. Foreign substance or scale stuck on contact surface between the valve [3] and valve seat [2].	1. Follow the procedure described in 9.2.2. and start up the product to remove the scale. Please contact us if the trouble does not stop.
	2. Sliding parts of the valve [3] and valve seat [2] do not move smoothly.	2. The product needs to be disassembled and cleaned. Please contact us.
	3. The normal working pressure exceeds the closing pressure.	3. Increase the difference between the set pressure and normal working pressure. If the set pressure needs to be readjusted, please contact us.
	4. The product is installed at outlet side of pressure reducing valve which is out of order, and the reduced pressure of the valve is getting higher than expected.	4. The pressure reducing valve needs to be repaired. If it is Yoshitake's product, please contact us.
The lever does not lift up. <AL-150L> <AL-140ML>	1. The inlet pressure is too low.	1. For AL-150L, raise the inlet pressure to more than 75% of the set pressure. For AL-140ML, adjust the inlet pressure so that the differential pressure becomes as specified in Table 1.
	2. Sliding parts of the valve [3] and valve seat [2] do not move smoothly.	2. The product needs to be disassembled and cleaned. Please contact us.
Does not stop blowing after lifting and letting go the lever. <AL-150L> <AL-140ML>	1. Foreign substance or scale stuck on contact surface between the valve [3] and valve seat [2].	1. Lift up the lever again to eliminate scale. Please contact us for repair if the trouble does not stop.
	2. Sliding parts of the valve [3] and valve seat [2] do not move smoothly.	2. The product needs to be disassembled and cleaned. Please contact us.