

MODEL AL-250, AL-250R, AL-260, AL-260R

RELIEF VALVE

PRODUCT MANUAL

Thank you very much for choosing the Yoshitake's product. To ensure the correct and safe use of the product, please read this manual before use. This manual shall be kept with care for future references.

The symbols used in this manual have the following meanings.



 Warning	This symbol indicates a potentially hazardous situation that, if not avoided, could result in death or serious injury.
 Caution	This symbol indicates a hazardous situation that, if not avoided, may result in minor or moderate injury or may result in only property damage.

Table of Contents

1. Usage of the Product	1
2. Specifications	1
3. Dimensions and Weight	2
4. Structure	3
5. Operation	3
6. Nominal Size Selection Chart	4
7. Installation	5
7.1 Piping example	6
8. Maintenance	6
8.1 Daily inspection	7
8.2 Regular inspection	7
8.3 Troubleshooting	8
8.4 Procedure for set pressure adjustment	9
Warranty Information	

YOSHITAKE

1. Usage of the Product

The model AL-250,250R,260,260R are the relief valves for the purpose of the regulating the pressure of the pulsating pressure and fluctuating pressure for the large capacity pump.

2. Specifications

Model	AL-250	AL-250R	AL-260	AL-260R
Structure	Closed type	Closed type with handle	Closed type	Closed type with handle
Application	Water, Oil, Other non-dangerous liquids			
Working pressure	0.05-1.0 MPa			
Working temperature	5-120°C	5-90°C	5-120°C	5-90°C
Connection	JIS Rc screwed			
Nominal size	15-50A			
Material	Spring case	Cast stainless steel	Cast bronze	
	Valve, valve seat	Stainless steel		
	Spring	Stainless steel		

* Handle type AL-250R and AL-260R are available for use in relief valve, which is easy to change the set pressure.

Warning

1. Do not apply the product to devices which do not allow any valve seat leakage.
* The product has allowable valve seat leakage and does not close completely (valve seat leakage cannot be zero).
2. Do not use the product for equipment or device which vibrates excessively.
* Failure to follow this notice may result in malfunction.



Caution

Please confirm that the indications on the product correspond with the specifications of the ordered product model before use.
* If they are different, do not use the product and contact us.

3. Dimensions and Weight

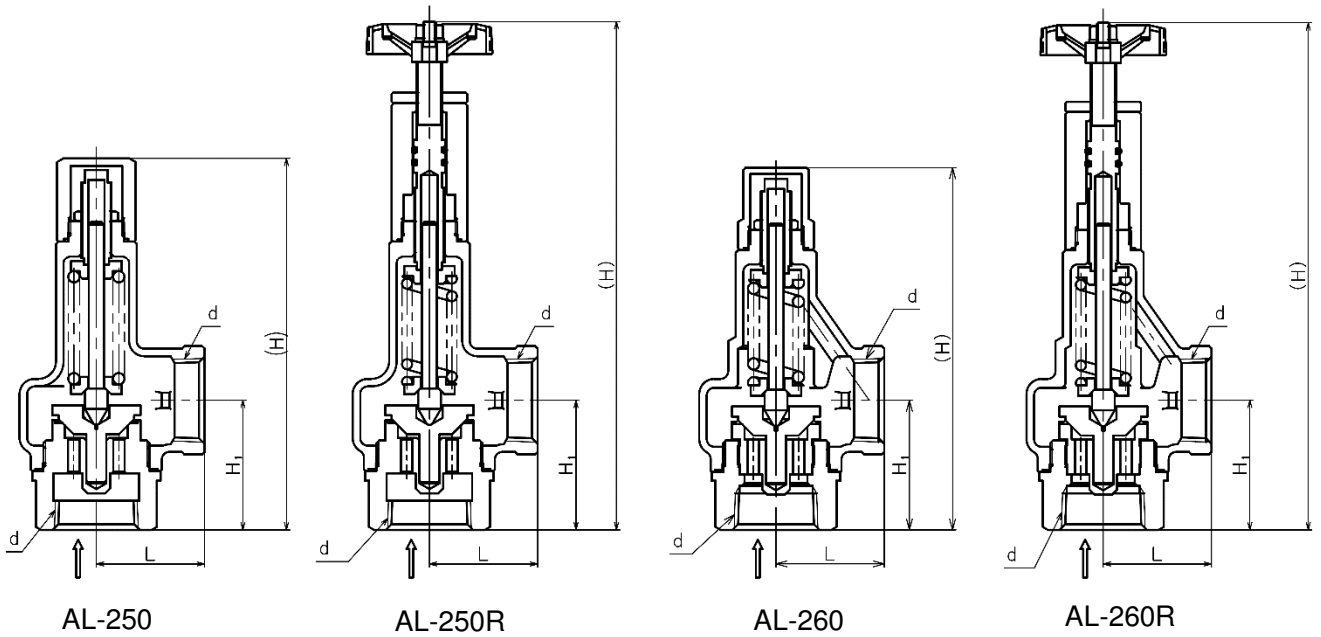
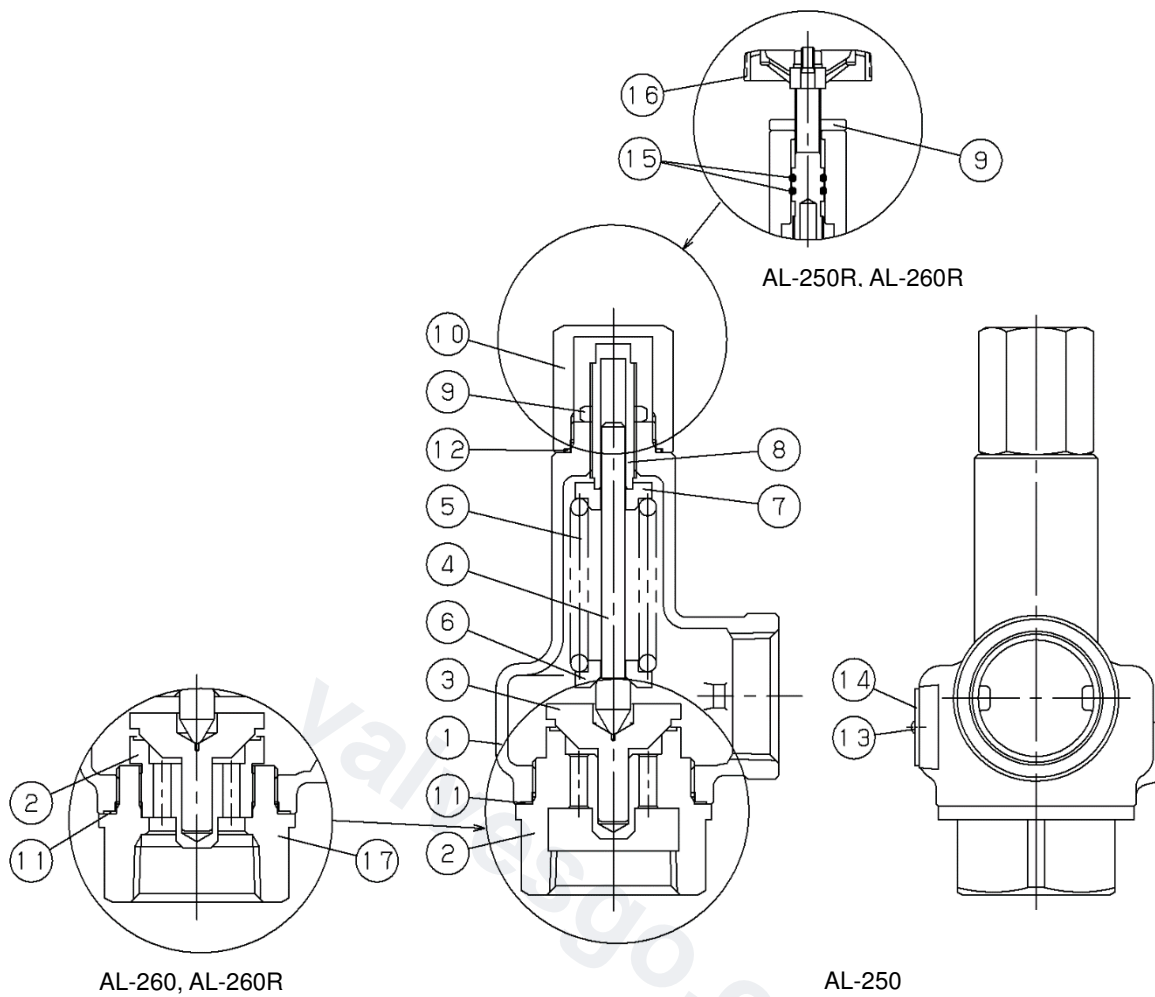

Fig.1 Dimensions

Nominal size	Dimensions [mm]							
	d	L	H ₁		H			
			AL-250 AL-250R	AL-260 AL-260R	AL-250	AL-250R	AL-260	AL-260R
15A	Rc 1/2	34	41	41	129	185	129	185
20A	Rc 3/4	38	45	45	132	190	131	190
25A	Rc 1	43	51.5	51.5	148	205	145	200
32A	Rc 1 1/4	50	63.5	63.5	184	245	184	245
40A	Rc 1 1/2	60	68.5	64.5	210	280	210	280
50A	Rc 2	75	80	80	250	315	250	315

Nominal size	Weight [kg]			
	AL-250	AL-250R	AL-260	AL-260R
15A	0.7	0.9	0.7	1.0
20A	0.9	1.1	0.9	1.2
25A	1.2	1.4	1.2	1.5
32A	2.2	2.5	1.9	2.2
40A	3.2	3.7	2.8	3.2
50A	5.6	6.0	4.9	5.3

4. Structure



No.	Part name	No.	Part name	No.	Part name
1	Spring case	7	Top spring plate	13	Rivet
2	Valve seat	8	Adjusting screw	14	Name plate
3	Valve	9	Lock nut	15	O ring
4	Spindle	10	Cap	16	Handle
5	Spring	11	Gasket	17	Valve Case
6	Bottom spring plate	12	Gasket		

Fig.2 Structure

5. Operation

When the pressure of inlet side of relief valve is increased and approached to the blowout pressure, the force of liquid pressure pushes the valve [3] upward and approaches to the force of spring [5] which pushes down the valve [3], and the valve [3] is opened after increasing more pressure, then the fluid is released. The pressure is controlled by changing the degree of valve depending on the inlet pressure.

6. Nominal Size Selection Chart

In case of the accumulation is 25% (Excess value to the setting pressure), the flow rate of each size can be referred on figure3.

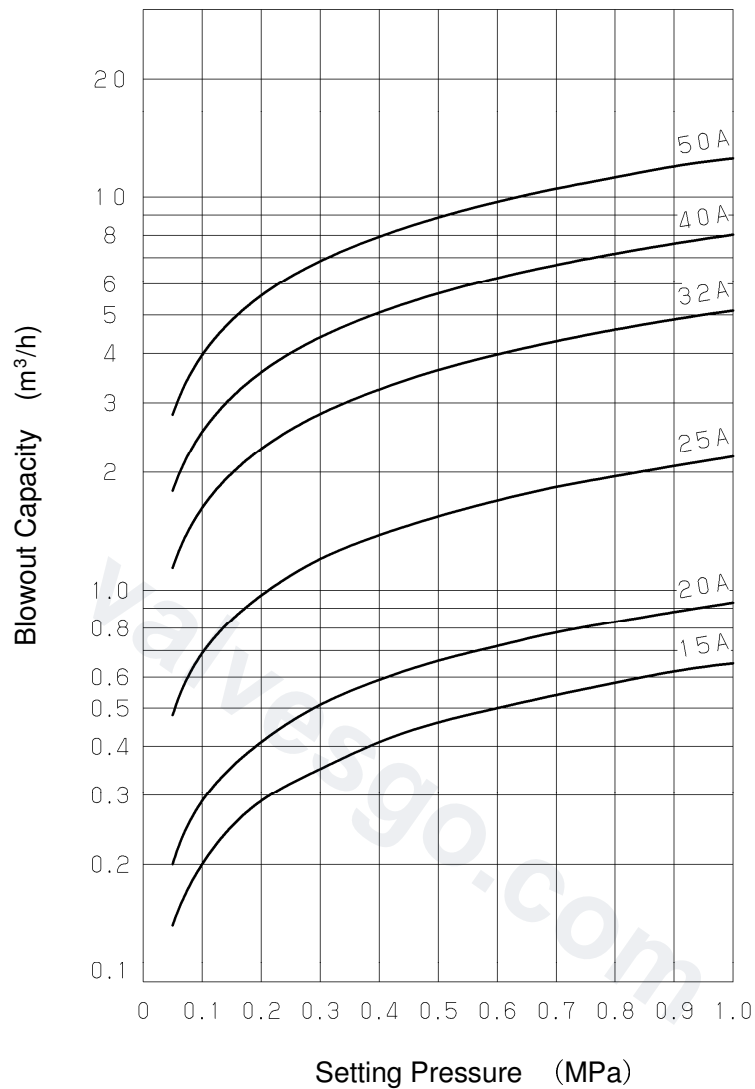

Fig.3 Nominal size selection chart

The blow out capacity for main pressure is in the following table.

Nominal size	Capacity < Accumulation : 25%> [m ³ /h]										
	Set pressure [MPa]										
	0.05	0.1	0.2	0.3	0.4	0.5	0.6	0.7	0.8	0.9	1.0
15A	0.14	0.20	0.29	0.35	0.41	0.46	0.50	0.54	0.58	0.62	0.65
20A	0.20	0.29	0.41	0.51	0.59	0.66	0.72	0.78	0.83	0.88	0.93
25A	0.49	0.69	0.98	1.20	1.38	1.54	1.69	1.83	1.96	2.07	2.19
32A	1.14	1.62	2.29	2.81	3.24	3.63	3.97	4.29	4.59	4.87	5.13
40A	1.79	2.53	3.58	4.39	5.07	5.67	6.21	6.71	7.17	7.61	8.02
50A	2.80	3.96	5.60	6.86	7.92	8.86	9.71	10.49	11.21	11.89	12.53

7. Installation

Warning

1. Do not install any closing device such as a stop valve at inlet or outlet sides of the product.
* Failure to follow this notice may result in damage to the pressure vessel because such closing device may hamper the blowout of the safety relief valve.
2. Install an exhaust pipe on outlet side of the product, and lead it to a place where there is no risk of physical damage even if fluid blows out.
* Failure to follow this notice may result in injury and scalds in case of fluid blow out.
3. Do not disassemble the product.
* Failure to follow this notice may prevent the product from functioning properly and lead to danger.
4. When installing, tighten the hexagonal part of the valve seat [2] for AL-250 and AL-250R, and the valve case [17] for AL-260 and AL-260R with a spanner.
Do not adjust its direction by rotating the outlet piping.
* Failure to follow this notice may result in scalds or injury due to blow-off caused by screw crack on the spring case [1] or losing of the spring case [1], the valve seat [2], and the valve case [17].
5. Do not apply viscous fluid that may make fixation of the valve and valve seat.
* Failure to follow this notice may prevent the product from functioning properly.

Caution

1. Before installing the product, remove foreign substances and scale from the piping.
* Failure to follow this notice may prevent the product from functioning properly.
Note that the customer will be required to pay repair charge for any defect that occurs due to foreign substances.
2. When installing the product, match the direction of fluid flow with the inlet and outlet of the product respectively.
* Failure to follow this notice may prevent the product from functioning properly.
3. Install the product vertically with the cap [10] facing upward.
* Failure to follow this notice may prevent the product from functioning properly.
4. Securely support and fasten the pipes.
Refer to the following "Pipe mount" and "Exhaust pipe".
* If an excessive stress is applied to the piping, the product may be deformed and not open/close.
5. Lead exhaust pipe to outside of buildings if there is a risk that fluid blowout causes alarm activation or contamination of the peripheral equipment.
* Improper placement may cause contamination of the peripheral equipment.
6. Connect the product to the pipes securely.
* Improper connecting may cause fluid leakage from the piping joint when vibration is applied, or may cause scalds in case that fluid is hot.
7. If there is a risk that condensate or rain water accumulates in exhaust pipe, attach drain pipe with the product and/or the exhaust pipe in a position where they can be drained.
* Failure to follow this notice may cause rust and result in malfunction.
8. Inner diameters of pipe mount and of exhaust pipe shall be more than those of each inlet and outlet of the product.
* Failure to follow this notice may result in malfunction or insufficient amount of blowout.
9. Secure enough space required for maintenance or inspections.
* Failure to follow this notice prevents maintenance and inspections being implemented.
10. Avoid rapid pressure change. Impact by a rapid pressure change, such as water hammer, may damage the product/parts.
11. Do not apply excessive load, torque or vibration to the product.
12. Select a proper model according to usage conditions including operation frequency and durability required.

- Cleaning the inside of the piping
 1. Please clean the inside of the pipe thoroughly and remove any dust or scales before installing the product. **Please note that all repairs for disorders due to foreign substances shall be charged.**
- Pipe mount
 1. Pipe mount should have sufficient strength and rigidity against stress which are induced by reaction force in opposite direction of the exhaust through the axis of the exhaust pipe.
 2. Pressure loss in pipe mount leads to decrease in the discharge volume and to unstable operation of the product. To prevent this from happening, install the product vertically as close as possible to the can body and the header. In addition, place the product in a position where maintenance and inspection can be done easily.
 3. Inner diameter of pipe mount shall be more than that of the product inlet.
- Exhaust pipe
 1. Install exhaust pipe and drip pan elbow so that the product cannot be subject to the stress caused by thermal expansion of equipment and by dilatation of the exhaust pipe due to thermal action of blowout.
 2. Inner diameter of exhaust pipe shall be more than that of the product outlet to avoid improper back pressure.

7.1 Piping example

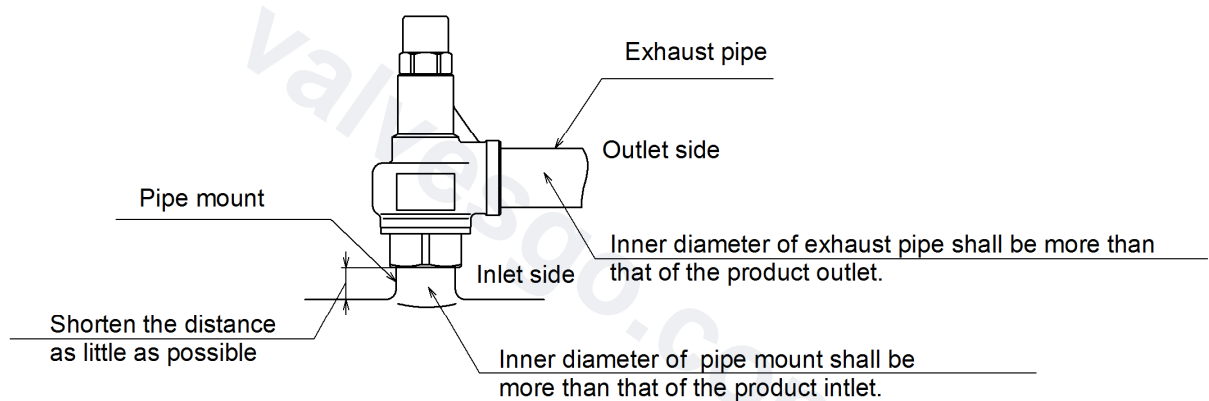



Fig.3 Piping example

8. Maintenance

Warning

1. Do not touch the product/pipes or the handle [16] with bare hands.
* Failure to follow this notice may result in scalds or injury in case that fluid is hot.
2. Do not touch the product unless it is necessary.
* Failure to follow this notice may result in scalds or injury in case that fluid is hot.
3. When checking the operation of the product, wear earplugs and stand clear of exhaust pipe end during inspection. Do not look down or touch the open end of the exhaust pipe.
* Failure to follow this notice may result in scalds or injury due to blow-off. Be aware that the product makes a loud noise at start-up.
4. Do not remove the cap [10].
* Failure to follow this notice may cause danger due to blow-off from the adjusting screw.
5. Do not disassemble the product.
* Please contact us if any abnormal condition is observed.

 **Caution**

1. Before applying higher pressure fluid to the product, check that no problems have occurred in the equipment on the piping.
 - * Failure to follow this notice may damage the equipment.
2. Completely discharge fluid from the product and piping before leaving the product not operated for a long time.
 - * Failure to follow this notice may cause foreign substances and scale inside of the piping and may result in malfunction of the product.
3. If the product is not operated for a long time, perform test working before starting operation.

8.1 Daily inspection

Check the following items while the system is in operation.

- Leakage from between the cap [10] and the gasket [12].
 - * Make sure to tighten the cap if it is loosen.
- Corrosion or crack on the product
- Leakage from the product under normal working pressure (check it visually and aurally).
- Leakage from the joint between the product and piping, and between the spring case and the valve seat.
- Leakage from between the cap [10] and the O ring [15]. (AL-250R, AL-260R)
 - * Please contact us if any abnormal condition is observed.

8.2 Regular inspection (once per 6 months)

Check the following items by regular inspection.

- Leakage from between the cap [10] and the gasket [12].
 - * Make sure to tighten the cap if it is loosen.
- Corrosion or crack on the product
- Leakage from the product under normal working pressure (check it visually and aurally).
- Leakage from the joint between the product and piping, and between the spring case and the valve seat.
- Leakage from between the cap [10] and the O ring [15]. (AL-250R, AL-260R)
- Check the operation of the product by raising fluid pressure to the set pressure.
 - * Please contact us if any abnormal condition is observed.

8.3 Troubleshooting

Trouble	Cause	Remedy
Blows at a pressure lower than the set pressure.	1. The product specifications are not consistent with the use condition.	1. Check the set pressure indication on the name plate. If the product is not suitable for the usage condition, replace it with a proper one.
	2. The pressure gauge is out of order.	2. Calibrate the pressure gauge or replace it with a new one.
	3. Foreign substance or scale stuck on contact surface between the valve [3] and valve seat [2].	3. Operate the product and eliminate the foreign substance and scale. Please contact us if the trouble does not stop.
	4. Damage on the contact surface of valve [3] and valve seat [2].	4. The product needs to be disassembled and its parts need to be replaced. Please contact us.
	5. The product does not keep the accuracy of its set pressure.	5. The set pressure needs to be readjusted. Please contact us.
Does not operate at the set pressure.	1. The product specifications are not consistent with the use condition.	1. Check the set pressure indication on the name plate. If the product is not suitable for the usage condition, replace it with a proper one.
	2. The product does not keep the accuracy of its set pressure.	2. The set pressure needs to be readjusted. Please contact us.
	3. The pressure gauge is out of order.	3. Calibrate the pressure gauge or replace it with a new one.
	4. Sliding parts of the valve [3] and valve seat [2] do not move smoothly.	4. The product needs to be disassembled and cleaned. Please contact us for repair.
	5. There is a back pressure at the piping of the product outlet.	5. Remove the back pressure. Change the piping layout not to allow the back pressure exist.
Does not stop blowing.	1. Foreign substance or scale stuck on contact surface between the valve [3] and valve seat [2].	1. The product needs to be disassembled and cleaned. Please contact us.
	2. Damage on the contact surface of valve [3] and valve seat [2].	2. The product needs to be disassembled and its parts need to be replaced. Please contact us.
	3. Sliding parts of the valve [3] and valve seat [2] do not move smoothly.	3. The product needs to be disassembled and cleaned. Please contact us.
	4. The normal working pressure exceeds the closing pressure.	4. Increase the difference between the set pressure and normal working pressure. If the set pressure needs to be readjusted, please contact us.
	5. The product is installed at outlet side of pressure reducing valve which is out of order, and the reduced pressure of the valve is getting higher than expected.	5. The pressure reducing valve needs to be repaired. If it is Yoshitake's product, please contact us.
Leakage from between the cap [10] and the O ring [15]. <AL-250R> <AL-260R>	1. Damage on the O ring [15].	1. The product needs to be disassembled and its parts need to be replaced. Please contact us.

* The product has allowable valve seat leakage and does not close completely (valve seat leakage cannot be zero).

8.4 Procedure for set pressure adjustment

Warning

1. To adjust the set pressure, turn the adjusting screw [8] (It is the handle [16] in case of AL-250R, AL-260R) slowly at the rotation of 1/4-1/3 and confirm the operation each time. Be careful of the sudden blowout when the handle are turned too much. In case of blowout, step away from the product immediately.
* Failure to follow this notice may result in injury and scalds due to blowout in case that fluid is hot.
2. Be sure to wear gloves while operating the handle of AL-250R and AL-260R
* Failure to follow this notice may result in burn and scalds in case that fluid is hot.

Caution

1. When the set pressure is adjusted, refer to the set pressure range shown in Table 2. Do not adjust the setting pressure beyond the bounds of this classification.
2. For AL-250R and AL-260R, be sure to turn the handle or tighten/loosen the lock nut by hand. Be careful not to turn it with excessive force or turn too much.
* Handle can be turned only within the limited numbers of turns. Using tools or turning it with excessive force causes damage to the handle or malfunction of the product.

- Procedure for adjusting the set pressure of AL-250 and AL-260 (See" Fig. 2 Structure.")
 1. Remove the cap [10] with a spanner etc.
 2. Loosen the lock nut [9] by turning it counterclockwise with a spanner etc.
 3. To increase the set pressure, turn the adjusting screw [8] clockwise. To decrease the set pressure, turn the adjusting screw [8] counterclockwise. Each turn must be slow and 1/4 to 1/3 of full turn. Also check the operation of the product per each turn.
 4. After the completion of adjustment, tighten the lock nut [9] by turning it clockwise.
 5. Tighten the cap [10].
- Procedure for adjusting the set pressure of AL-250R and AL-260R (See" Fig. 2 Structure.")
 1. Loosen the lock nut [9] by turning it counterclockwise by hand. (Outer peripheral surface of the lock nut [9] is knurled for easy turning by hand.)
 2. To increase the set pressure, turn the handle [16] clockwise. To decrease the set pressure, turn the handle [16] counterclockwise. Each turn must be slow and 1/4 to 1/3 of full turn. Also check the operation of the product per each turn.
 3. After the completion of adjustment, tighten the lock nut [9] by turning it clockwise by hand.

Set pressure adjustment must be done according the set pressure range shown in Table 2. Please note that the range differs per size.

Table 2 Set pressure range

Nominal size	Set pressure range (MPa)					
	A	B	C	D	E	F
15A	0.05~0.2	0.21~0.4	0.41~0.55	0.56~0.75	0.76~1.0	-----
20A	0.05~0.2	0.21~0.35	0.36~0.45	0.46~0.6	0.61~0.75	0.76~1.0
25A	0.05~0.2	0.21~0.35	0.36~0.45	0.46~0.55	0.56~0.8	0.81~1.0
32A	0.05~0.2	0.21~0.4	0.41~0.65	0.66~1.0	-----	-----
40A	0.05~0.2	0.21~0.4	0.41~0.65	0.66~0.8	0.81~1.0	-----
50A	0.05~0.2	0.21~0.4	0.41~0.65	0.66~0.8	0.81~1.0	-----