

AL-32

Full bore type	Lift type	Safety valve	Relief valve
Safety relief valve	Lever type	Closed type	Dash-pot structure
Handle type	Stainless	High-pressure gas testing product	
Diaphragm	Non-leakage		

■Features

1. All stainless steel (SCS14A and SUS 316 for trim parts) offering high corrosion resistance.
2. Closed structure prevents fluid leakage.

■Specifications

Structure		Closed type
Application		Steam, air, water, oil, other non-dangerous fluids
Working pressure		0.05-1.0 MPa
Working temperature		5-220°C *
Material	Spring case	Stainless steel
	Valve	Stainless steel (SCS14A)
	Valve seat	Stainless steel (SUS316)
	Adjusting spring	Stainless steel
Connection		JIS10K loose flange

- * The maximum temperature is 150°C when using for water, oil, or other fluid.
- AL-32T is recommended for hot and cold water application.
- Please refer to the chart in P. 8-80 for set pressure range.

■Dimension and Weight

Nominal size	Dimension (mm)				Flow area πD_L^2 (mm ²)	Weight (kg)
	D	L	H _i	H		
15A	16	63	97	185	20.1	2.4
20A	21	87	101	187	34.6	2.8
25A	26	92	119	215	53.0	4.4
32A	33	99	135	255	93.3	5.2
40A	41	109	140	281	135.2	6.5
50A	51	114	162	332	208.2	11.3

* The outlet flange is 1 size larger than the nominal size.



AL-32

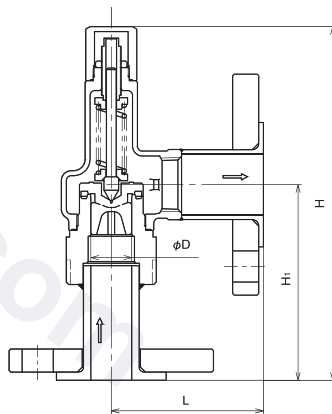

·AL-32 for steam (Saturated temperature)

<Pressure vessel structure standard>

(kg/h)

Nominal size (mm) \ Pressure MPa	0.05	0.1	0.2	0.3	0.4	0.5	0.6	0.7	0.8	0.9	1.0
15A	15	20	29	40	50	60	70	80	90	100	109
20A	27	35	51	69	87	104	121	138	155	172	189
25A	42	54	78	105	133	159	186	212	237	263	289
32A	70	91	132	178	224	268	313	356	400	443	487
40A	105	136	198	266	335	402	468	534	599	664	729
50A	163	211	306	411	518	621	723	824	924	1025	1126

·AL-32, 32T, 32TML, for air (20°C)

<Pressure vessel structure standard>

(kg/h)

Nominal size (mm) \ Pressure MPa	0.05	0.1	0.2	0.3	0.4	0.5	0.6	0.7	0.8	0.9	1.0
15A	25	33	48	65	81	98	114	131	147	164	181
20A	44	57	83	111	140	169	197	226	254	283	311
25A	67	87	127	171	215	258	302	346	390	433	477
32A	113	147	214	288	362	435	509	582	656	730	803
40A	169	221	321	431	542	652	762	872	982	1093	1203
50A	262	341	496	666	836	1006	1176	1346	1516	1687	1857

·AL-32, 32T, 32T-N, 32ML, 32TML-N for water (accumulation 25%)

<Yoshitake standard>

(m³/h)

Nominal size (mm) \ Pressure MPa	0.05	0.1	0.2	0.3	0.4	0.5	0.6	0.7	0.8	0.9	1.0
15A	0.4	0.5	0.9	1.1	1.3	1.5	1.6	1.8	1.9	2.0	2.1
20A	0.6	0.9	1.6	2.0	2.3	2.6	2.8	3.1	3.3	3.5	3.7
25A	1.0	1.5	2.5	3.1	3.6	4.0	4.4	4.7	5.1	5.4	5.7
32A	1.8	2.6	4.5	5.5	6.3	7.1	7.8	8.4	9.0	9.5	10.0
40A	2.7	3.8	6.5	7.9	9.2	10.3	11.3	12.2	13.0	13.8	14.6
50A	4.1	5.9	10.0	12.3	14.2	15.9	17.4	18.8	20.1	21.3	22.4

* Please refer to the chart in P.8-12 for the calculation procedure for nominal size selection.