

# DP-10 Series

TYPE DP-10·13, TYPE DP-10D·13D  
TYPE DP-12·14, TYPE DP-12D·14D  
TYPE DP-15·17, TYPE DP-15D·17D  
TYPE DP-16·18, TYPE DP-16D·18D

## Instruction Manual

Thank you very much for purchasing our solenoid valves.

Please read this instruction manual thoroughly before using the solenoid valves, so that you may do so correctly and safely. Please carefully store this bulletin in a handy place.

— — — — — The following safety symbols are used in this manual. — — — — —

### Warning

This symbol indicates a potentially hazardous situation that, if not avoided, could result in death or serious injury.

### Caution

This symbol indicates a hazardous situation that, if not avoided, may result in minor or moderate injury. (“Caution” may also be used to indicate other unsafe practices or risks of property damage.)

## Contents

1. Overview	1
2. Specifications & Performance	1
3. Dimensions & Weight	2~3
4. Operation	4
5. Nominal Size Selection Method	
5. 1 Nominal Size Selection Chart	5~9
5. 2 Calculating the Nominal Size	10
6. Installation	
6. 1 Piping Example	10
6. 2 Wiring Method	11
6. 3 Warning & Caution for Installation	12
7. Operating Procedure	
7. 1 Warning & Caution for Operation	13
7. 2 Test Working	13
8. Maintenance Procedure	
8. 1 Warning & Caution for Maintenance	14
8. 2 Troubleshooting	15
8. 3 Disassembly Procedure	15
8. 4 Disassembly Drawing	16~17
After Sales Service	

# YOSHITAKE

■ EPDT-028d ■

## 1. Overview

The DP-10 series are compact, Pilot-Operated and Piston type high reliability solenoid valves featuring wide application for such various as steam, air, water and oil. And also wide products variation for such various requirements as AC/DC voltage, normally closed/opened and brass/stainless made.

## 2. Specifications & Performance

Model	DP-10	DP-13	DP-15	DP-17	DP-12	DP-14	DP-16	DP-18	
Type	Piston type				Diaphragm type				
Application	Steam·Air·Water·Oil (20cSt or less)				Air·Water·Oil (20cSt or less)				
Working pressure	0.05~1.0 MPa				0~1.0 MPa				
	(Not available for use with vacuum)								
Min. working differential pressure	0.05 MPa (Horizontal installation: more than 0.1MPa)				0 MPa (Horizontal installation: more than 0.1MPa)				
Valve seat leakage	50 mL/min (For Air: 0.6MPa)				None				
Max. temperature	180 °C				60 °C				
Operation	Normally closed								
Material	Body	Bronze		Stainless Steel		Bronze		Stainless Steel	
	Valve	Stainless Steel				NBR (Diaphragm)			
	Disc	PTFE				—————			
Connection	JIS Rc Screwed	JIS 10K FF Flanged	JIS Rc Screwed	JIS 10K FF Flanged	JIS Rc Screwed	JIS 10K FF Flanged	JIS Rc Screwed	JIS 10K FF Flanged	

- Viton (FKM) diaphragm is also available for diaphragm type.
- DC coil is also available. (DP-□□D)
- Products complying with Water Supply Law will be DP-12-N and DP-14-N.

### Coil specification

Rating voltage	AC100/200V	AC110/220V	DC24V
	Selective connection type 50/60Hz		
Allowable regulation	±10% on rating voltage		
Rated current	0.42/0.21A	0.38/0.19A	1.13A
Starting current	1.64/0.82A	1.48/0.74A	—————
Class of coil insulation	Class "H"		
Ingress protection code	IP64		
Solenoid enclosure	Dust tight·Splash proof		
Insulation resistance	50MΩ and more/500V Megger		
Voltage resistance test	1500V/min		

### Caution

Please collate with attached nameplate and specification of ordered model.  
\* Please consult factory in case they do not match each other.

### 3. Dimensions & Weight

#### ■ DP-10/15

(DP-15: 15-10A)

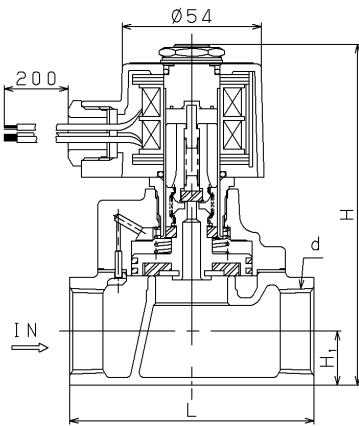

#### ■ DP-10D/15D

(DP-15: 15-50A)

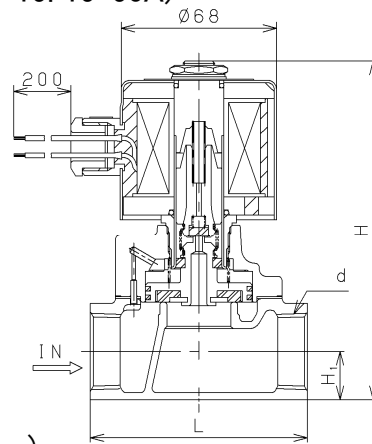

(mm)

Nominal Size	d	L	H <sub>1</sub>	H		Wight (kg)	
				DP-10/15	DP-10D/15D	DP-10/15	DP-10D/15D
10A	Rc 3/8	70	14.5	119	134	1.2	2.0
15A	Rc 1/2	70	14.5	119	134	1.2	2.0
20A	Rc 3/4	80	17.5	126	141	1.4	2.2
25A	Rc 1	95	21.0	133	148	1.8	2.6
32A	Rc 1 1/4	110	26.0	155	170	2.6	3.4
40A	Rc 1 1/2	120	29.5	162	177	3.2	4.0
50A	Rc 2	140	36.5	177	192	5.1	5.9

#### ■ DP-13/17

(DP-17 is welded flange type.)

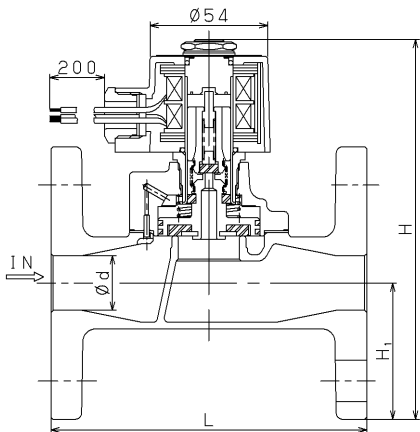

#### ■ DP-13D/17D

(DP-17D is welded flange type.)

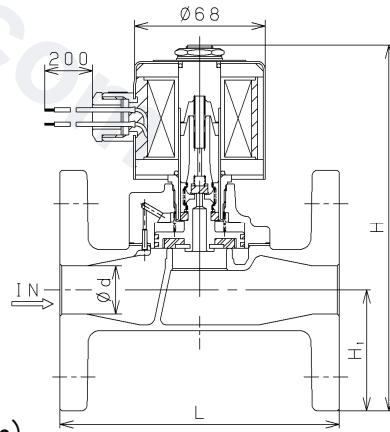

(mm)

Nominal Size	d	L	H <sub>1</sub>	H		Weight (kg)	
				DP-13/17	DP-13D/17D	DP-13/17	DP-13D/17D
15A	15	120	47.5	152.0	167	2.7	3.5
20A	20	130	50.0	158.5	174	3.3	4.1
25A	25	145	62.5	174.5	190	4.8	5.6
32A	32	160	67.5	196.5	212	6.6	7.4
40A	40	170	70.0	202.5	218	7.3	8.1
50A	50	195	77.5	217.5	233	10.0	10.8
65A*	50	198	87.5	227.5	243	13.5	14.3

\* 65A is for DP-13/13D only.

■ DP-12/16  
(DP-16: 15-50A)

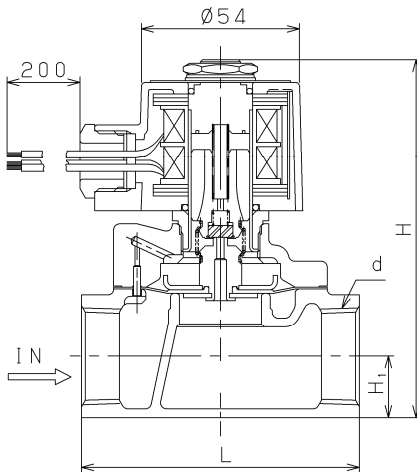

■ DP-12D/16D  
(DP-16D: 15-50A)

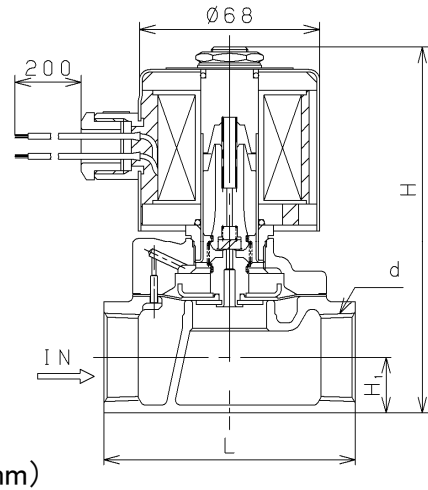

Nominal Size	d	L	H <sub>1</sub>	H		Weight (kg)	
				DP-12/16	DP-12D/16D	DP-12/16	DP-12D/16D
10A	Rc 3/8	70	14.5	109.5	124	1.1	1.9
15A	Rc 1/2	70	14.5	109.5	124	1.1	1.9
20A	Rc 3/4	80	17.5	116.5	131	1.3	2.1
25A	Rc 1	95	21.0	123.5	138	1.7	2.5
32A	Rc 1 1/4	110	26.0	150.5	166	2.5	3.3
40A	Rc 1 1/2	120	29.5	157.5	173	3.1	3.9
50A	Rc 2	140	36.5	172.5	187	5.0	5.8

■ DP-14/18  
(DP-18 is welded flange type.)

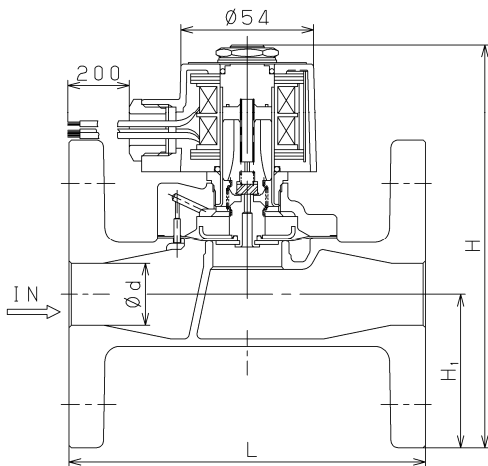

■ DP-14D/18D  
(DP-18D is welded flange type.)

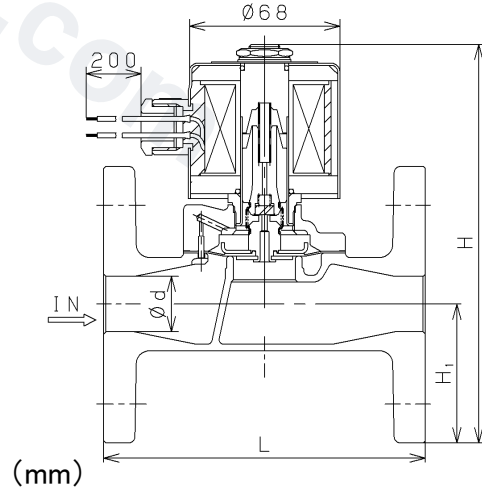

Nominal Size	d	L	H <sub>1</sub>	H		Weight (kg)	
				DP-14/18	DP-14D/18D	DP-14/18	DP-14D/18D
15A	15	120	47.5	142.5	157	2.6	3.4
20A	20	130	50.0	149.0	164	3.2	4.0
25A	25	145	62.5	165.0	180	4.7	5.5
32A	32	160	67.5	192.0	207	6.5	7.3
40A	40	170	70.0	198.0	213	7.2	8.0
50A	50	195	77.5	213.0	228	9.9	10.7

## 4. Operation

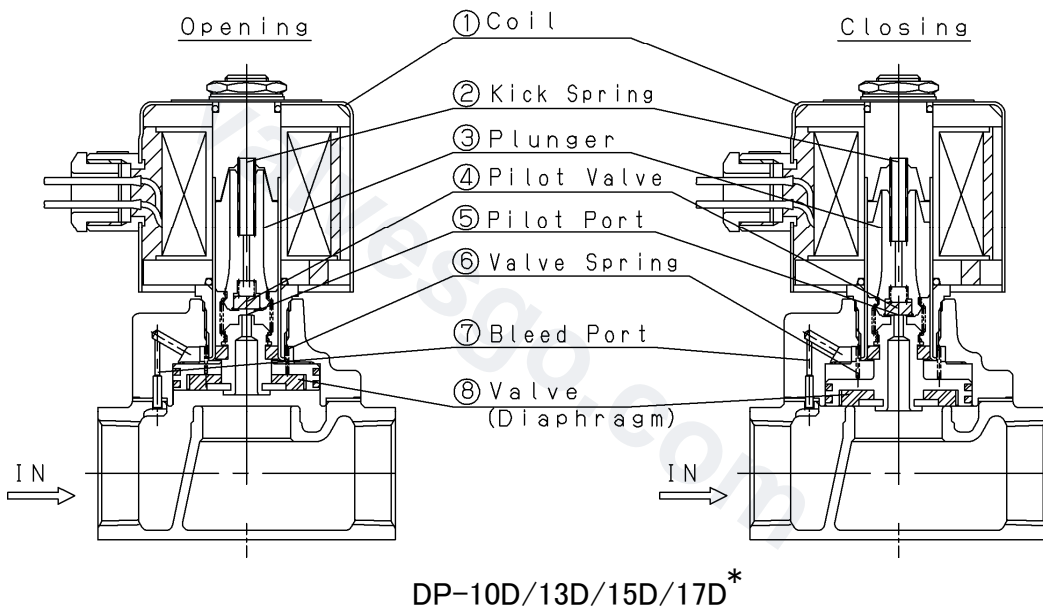
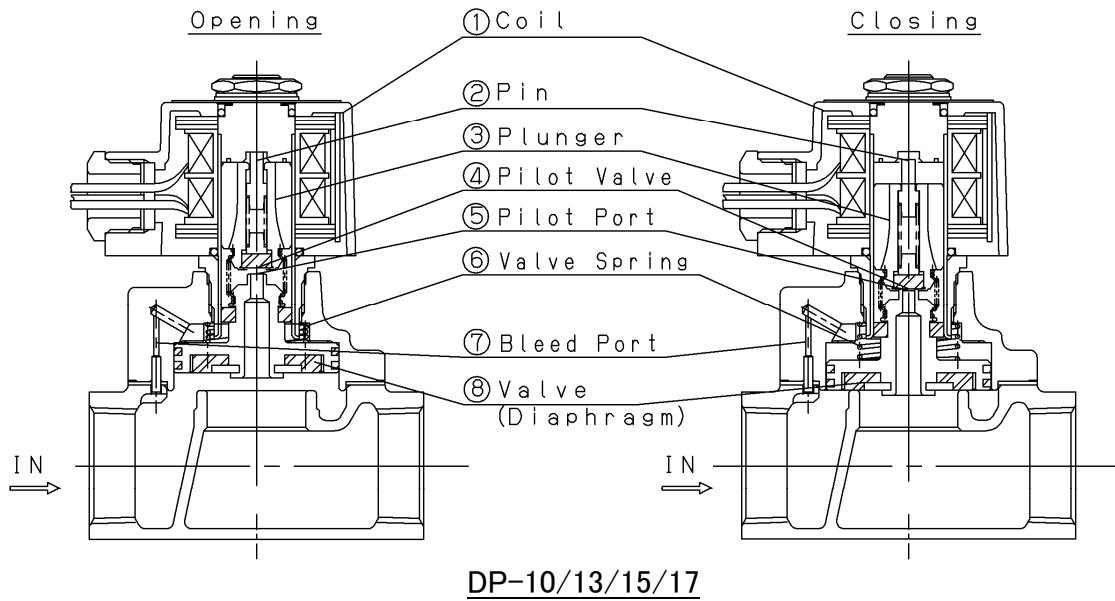

\* The structure differs slightly for DP-12/14/16/18/12D/14D/16D/18D.

### (1) Operation

When the power is turned ON, the coil① is magnetized and the plunger③ is sucked up, thereby open the pilot valve④. The pressure at the upper part of the valve (diaphragm)⑧ flows to the outlet side via pilot port⑤, causing a pressure drop. The valve (diaphragm)⑧ is then pushed up by the inlet pressure, and the valve is opened.

### (2) Closing operation

When the power is turned OFF, the plunger③ is pushed down by a pin/kick spring② and dead weight, thereby close the pilot valve④. The inlet pressure is introduced through the bleed port⑦ to upper part of the valve (diaphragm)⑧, thereby equalize the inlet pressure. The valve (diaphragm)⑧ is then pushed down and closed by the pin/kick spring② and the valve spring⑥.

## 5. Nominal Size Selection Method

### 5. 1 Nominal Size Selection Chart

■ Piston type (For steam)

(DP-10/13/15/17/10D/13D/15D/17D)

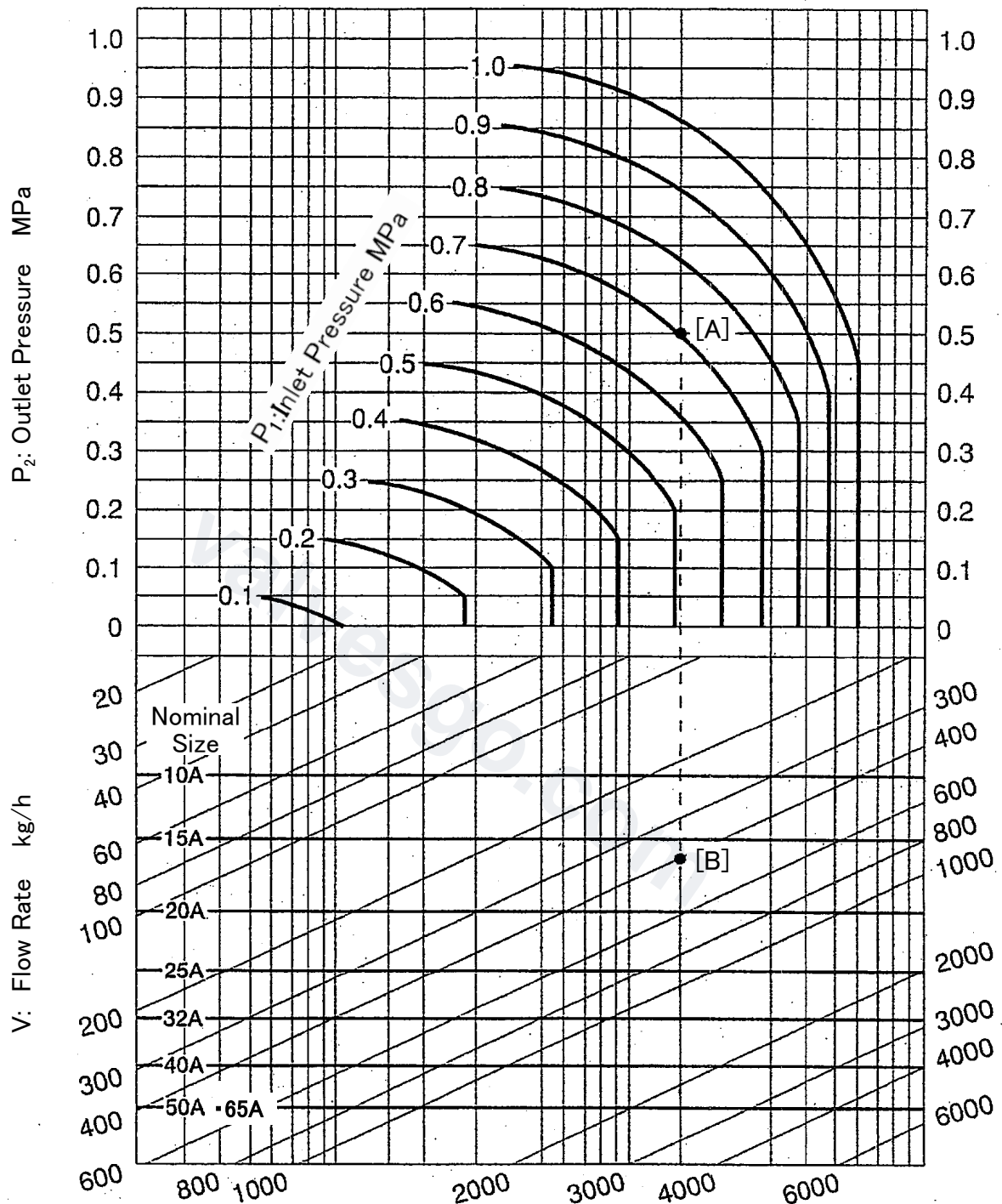

#### 【Example】

Under the following conditions, the appropriate nominal size would be determined as described below. Inlet pressure( $P_1$ ): 0.7MPa; Outlet pressure( $P_2$ ): 0.5MPa; Flow rate ( $W$ ): 400kg/h. First, find the point[A] where ( $P_1$ ) and ( $P_2$ ) intersect. Next find the point [B] where a line drawn straight down from point[A] intersects the ( $W$ ) line. In the above example, the point[B] is located between the 15A and 20A nominal size valves, so larger size of 20A should be selected.

■ Piston type (For air)

(DP-10/13/15/17/10D/13D/15D/17D)

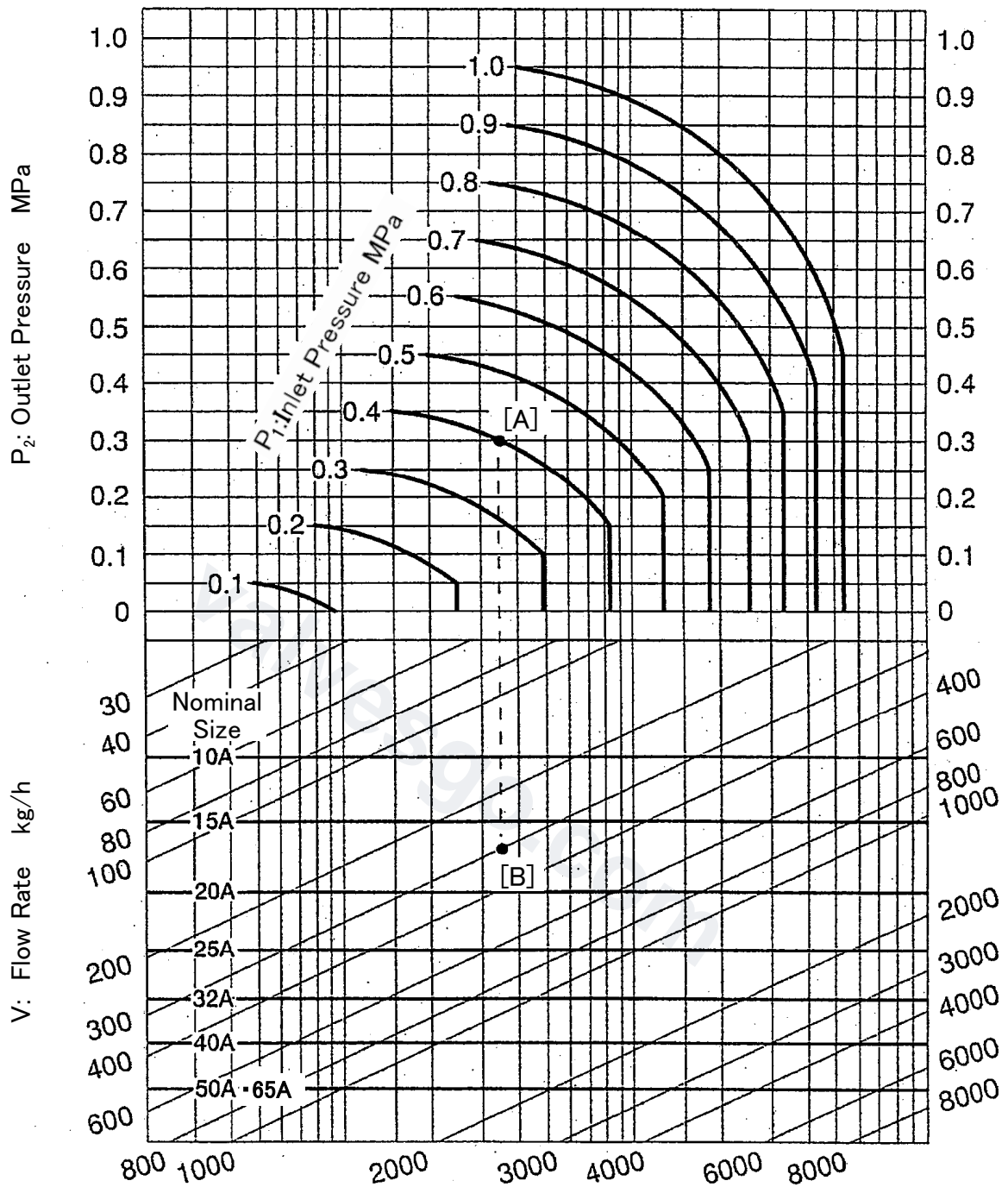

**【Example】**

Under the following conditions, the appropriate nominal size would be determined as described below. Inlet pressure( $P_1$ ): 0.4MPa; Outlet pressure( $P_2$ ): 0.3MPa; Flow rate ( $Q$ ) of air(20°C): 300m<sup>3</sup>/h(Normal condition). First, find the point[A] where ( $P_1$ ) and ( $P_2$ ) intersect. Next, find the point[B] where a line drawn straight down from point[A] intersects the ( $Q$ ) line. In the above example, the point[B] is located between the 15A and 20A nominal size valves, so the larger size of 20A should be selected.

■ Piston type (For water)

(DP-10/13/15/17/10D/13D/15D/17D)

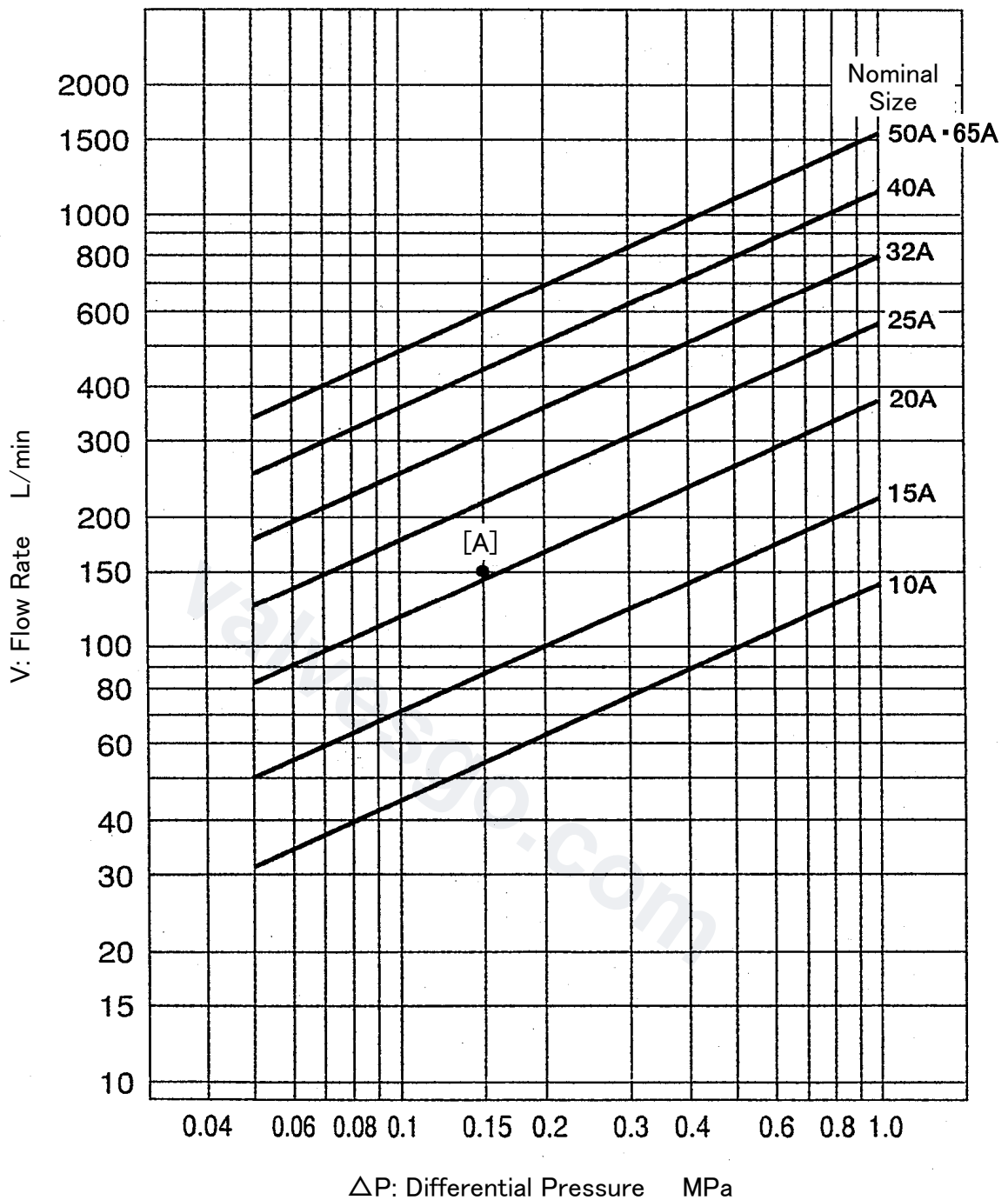

**【Example】**

Under the following conditions, the appropriate nominal size would be determined as described below. Inlet pressure( $P_1$ ): 0.5MPa; Outlet pressure( $P_2$ ): 0.35MPa; Flow rate (V): 150L/min. First, find the point[A] where (V) and  $(\Delta P) = (P_1) - (P_2)$ . In the above example, the point[A] is located between the 20A and 25A nominal size valves, so the larger size of 25A should be selected.

■ Diaphragm type (For air)

(DP-12/14/16/18/12D/14D/16D/18D)

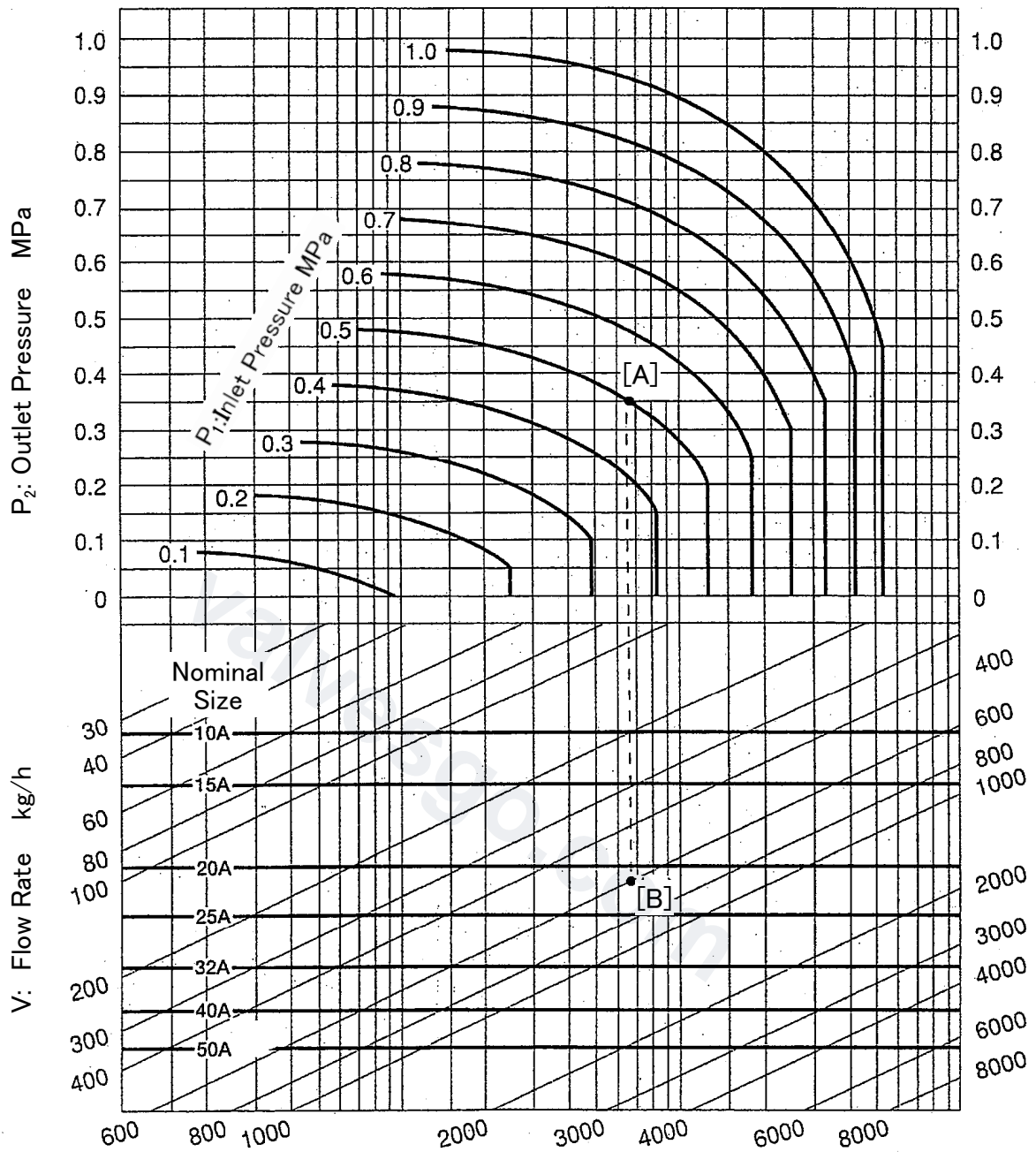

**【Example】**

Under the following conditions, the appropriate nominal size would be determined as described bellow. Inlet pressure(P<sub>1</sub>): 0.5MPa; Outlet pressure(P<sub>2</sub>): 0.35MPa; Flow rate (Q) of air(20°C): 600m<sup>3</sup>/h(Normal condition). First, find the point[A] where (P<sub>1</sub>) and (P<sub>2</sub>) intersect. Next, find the point[B] where a line drawn straight down from point[A] intersects the (Q) line. In the above example, the point[B] is located between the 20A and 25A nominal size valves, so the larger size of 25A should be selected.

■ Diaphragm type (For water)  
 (DP-12/14/16/18/12D/14D/16D/18D)

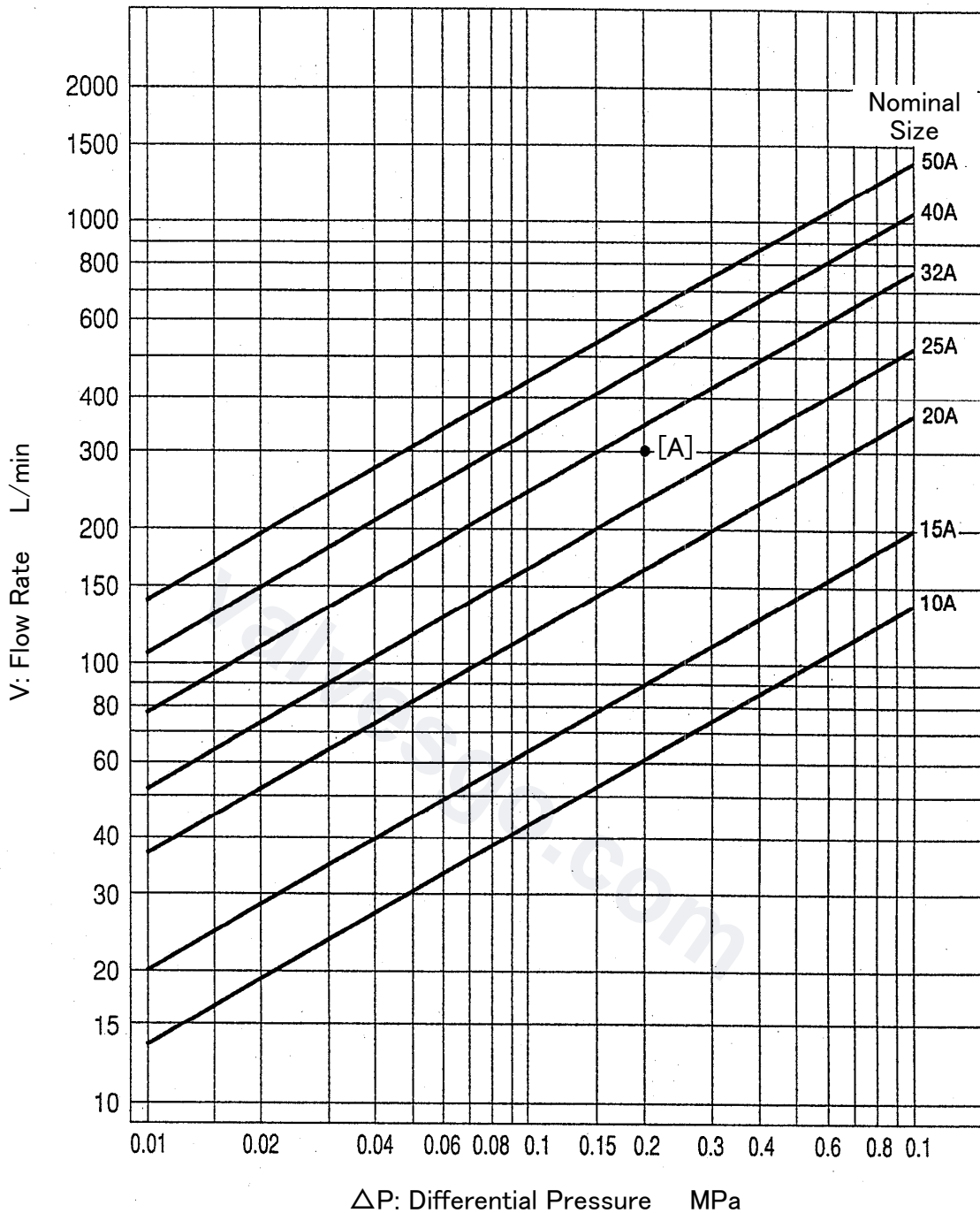

**【Example】**

Under the following conditions, the appropriate nominal size would be determined as described below. Inlet pressure( $P_1$ ): 0.7MPa; Outlet pressure ( $P_2$ ): 0.5MPa; Flow rate (V): 300L/min. First, find the point[A] where (V) and ( $\Delta P = (P_1) - (P_2)$ ). In the above example, the point[A] is located between the 25A and 32A nominal size valves, so the larger size of 32A should be selected.

## 5. 2 Calculating the Nominal Size

### ■ Formula for Cv value calculation

《For steam》

$$\text{When } P_2 > \frac{P_1}{2}$$

$$Cv = \frac{Wk}{138 \sqrt{\Delta P (P_1 + P_2)}}$$

$$\text{When } P_2 \leq \frac{P_1}{2}$$

$$Cv = \frac{Wk}{120 P_1}$$

《For air》

$$\text{When } P_2 > \frac{P_1}{2}$$

$$Cv = \frac{Q}{2940} \sqrt{\frac{(273+t) G}{\Delta P (P_1 + P_2)}}$$

$$\text{When } P_2 \leq \frac{P_1}{2}$$

$$Cv = \frac{Q \sqrt{(273+t) G}}{2550 P_1}$$

《For liquid》

$$Cv = \frac{0.365 V \sqrt{G}}{\sqrt{\Delta P}}$$

Cv : Cv value of the nominal size

W : Max. steam flow rate [kg/h]

Q : Max. gas flow rate [m<sup>3</sup>/h(Normal condition)]

V : Max. liquid flow rate [m<sup>3</sup>/h]

k :  $1 + 0.0013 \times \{\text{Super-heat Steam Temp. [}^\circ\text{C]} - \text{Saturated Steam Temp. [}^\circ\text{C]}\}$

G : Specific gravity (For gas, relative to air; For liquid, relative to water)

P<sub>1</sub> : Inlet pressure [MPa·A]

P<sub>2</sub> : Outlet pressure [MPa·A]

ΔP : P<sub>1</sub> - P<sub>2</sub> [MPa]

### ■ Cv value

Nominal size	10A	15A	20A	25A	32A	40A	50A	65A
Piston type	3.1	4.9	8.2	12.4	17.7	25.0	33.6	33.6
Diaphragm type	3.0 (1.2)	4.4 (1.7)	8.1 (3.2)	11.5 (4.6)	17.0 (6.8)	23.3 (9.3)	30.5 (12.2)	

\* In case of inlet/outlet pressure differential is less than 0.01MPa, Cv value shown in brackets should be adapted.

## 6. Installation

### 6. 1 Piping Example

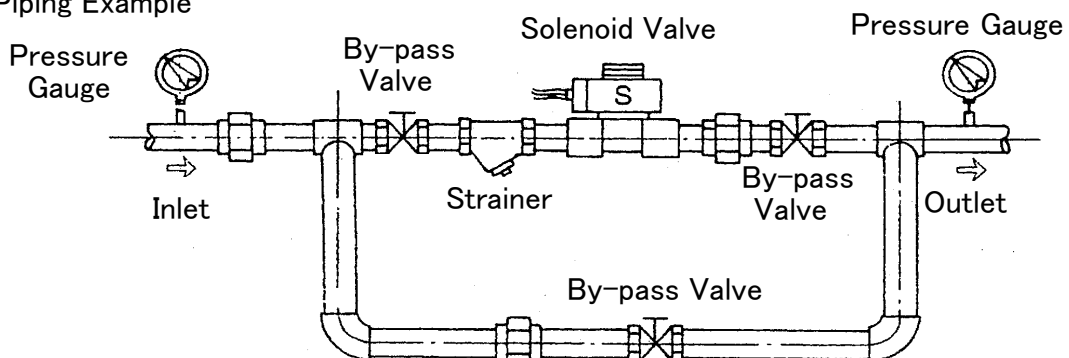

\* When the valve is used at 0.1MPa or less, mount the valve to the horizontal piping and the coil being at the top.

## 6. 2 Wiring Method

(1) Wiring differs according to the voltage, AC100V or 200V (AC110V or 220V/AC120 or 240V). Wire the coil according to the instruction on the label attached to the coil. In order to prevent faulty or erroneous wiring, especially wiring in a dark or narrow space, it is recommended that each of the lead wires be clearly identified with different colors that can be easily recognized.

(2) Do not unnecessarily pull the lead wires, and avoid subjecting them to excessive loads when wiring and use.

(3) Use electric wires which have a core of 0.75mm<sup>2</sup> or more.

(4) Use a fuse (2 to 3) to protect the electric circuit. Use a circuit protector as follows if the valve is used in a fuel supply system.

Rating voltage 100V: 0.5A circuit protector

Rating voltage 200V: 0.3A circuit protector

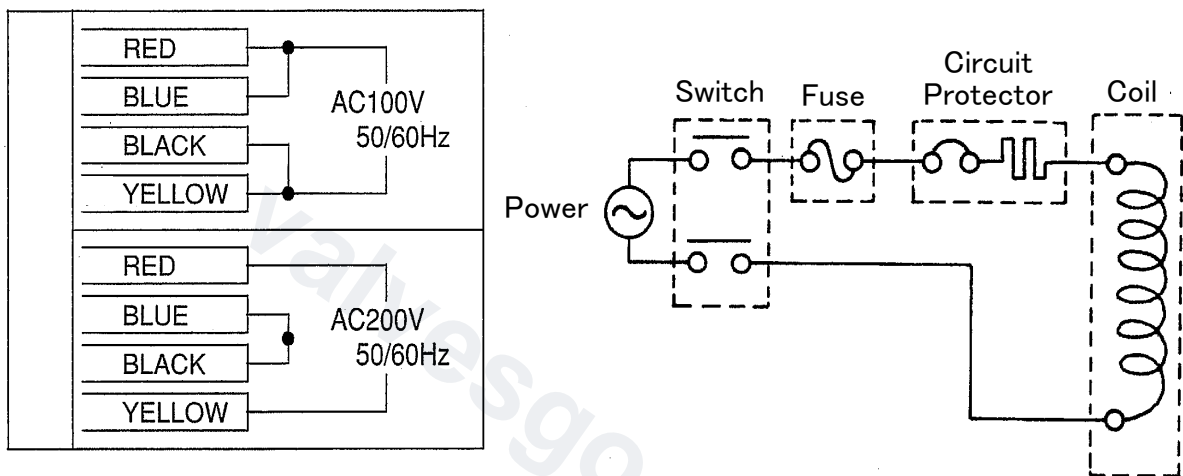

● DC coil has two non-selective lead wires (red and black).

### 6. 3 Warning & Caution for Installation

#### Warning

- (1) When there is a risk of having life hazard, harming a body or property by the malfunction of the solenoid valve, please install the safety device which operates interception, opening, warnings on the basis of machinery or device.
- (2) The Valves is not for explosive atmosphere.
  - \* It is not explosion-proof construction.
- (3) Carry out the cable connection only after confirming that no power is supplied.
  - \* May cause an electric shock.
- (4) Carry out the connection after confirming the rated voltage and follow to the instruction.
  - \* Erroneous cable connection may cause an electric shock or fire.
- (5) Do not turn on electricity without coil on solenoid valve.
  - \* May result in fire caused by an over current.

#### Caution

- (1) For piston type solenoid valve, the minimum differential pressure between inlet and outlet side must be more than 0.05MPa.
  - \* May result in an abnormal operation.
- (2) Vertical or horizontal installation is possible, but the coil must be installed above the horizontal level.
  - \* May result in a short circuit.
- (3) When using less than 0.1MPa pressure, the solenoid valve should be installed horizontally with the coil up.
  - \* May result in an abnormal function.
- (4) Remove foreign matter and scales from the lines before connecting the valve.
  - \* Failure to do so may prevent the valve from functioning correctly.
- (5) In case specifying installing direction, install inlet and outlet correctly.
  - \* Failure to do so may affect the original performance.
- (6) Install a strainer (Recommendation: 80-100mesh) at the valve inlet side.
  - \* Failure to do so may prevent the valve from functioning correctly.
- (7) Do not apply excessive load, torque or vibration to the valve.
  - \* Doing so may result in malfunction or drastically shortened service life.
- (8) Provide space around the valve so that the valve can be easily disassembled and inspected.
  - \* May not be able to do the maintenance.
- (9) When using in the outdoor, set the eaves at the product to keep rain away from the products and treat waterproof at the wire connection part.
  - \* May result in a short circuit.
- (10) Do not apply insulation around the solenoid coil.
  - \* May cause an abnormal function.

## 7. Operating Procedure

### 7. 1 Warning & Caution for Operation

#### Warning

- (1) Prior to letting the application in the system, make sure that all connecting part are properly connected and there is no danger when the application flows out of pipe end.
  - \* May result in burn when application blow out.
- (2) In case of using high temperature fluid, do not touch the valve directly bare hands.
  - \* May result in burn.
- (3) The temperature of coil will be increased when applying current and reach high temperature, so please do not touch with bare hands.
  - \* May result in burn.
- (4) Do not touch at terminal area of electronic wiring (bare live part) for solenoid valve.
  - \* May result in receiving an electric shock.
- (5) Do not tighten hexagon bolts at cap of solenoid valve excessively.
  - \* May result in a leakage because of breakage gasket.

#### Caution

- (1) In case of no operation for a long time, perform test working before start operation again.

- (1) When the product is used with AC voltage, it may produce a buzzing sound depending on the conditions of use.

### 7. 2 Test Working

#### Test Working Procedure

When installing new piping or restart the system after shutdown for a long period of time, close the stop valve in front and after the solenoid valve and remove the foreign material and scales completely via by-pass line before operation.

- (1) Before flow the fluids to solenoid valve, operate 2 to 3 times and confirm the sound caused by plunger when the coil turns on.
- (2) Fully open the stop valve at the outlet side.
- (3) Making the solenoid valve into open position, and open the stop valve at the inlet side gradually up to half opening and confirm the fluids flow to the end of piping.
- (4) Gradually close the stop valve at the outlet side, and confirm the fluids not to leak from the solenoid valve and connection part of piping.
- (5) Making the solenoid valve into close position, and fully open the stop valve and both inlet and outlet side.
- (6) On-off the solenoid valve 2 to 3 times, and confirm the solenoid valve operate certainly.
- (7) Making the solenoid valve into close position, and confirm no leakage at the end of piping.

In case there is abnormal in some way, take action to improve the situation by referring to “8.2 Troubleshooting”.

## 8. Maintenance Procedure

### 8. 1 Warning & Caution for Maintenance

#### Warning

- (1) Carry out the disassembling and maintenance only after confirming that no power is supplied.
  - \* May cause an electric shock.
- (2) Completely discharge internal pressure from the valves, lines, and cool the valves down to a level where you can touch it with bare hands disassembly and inspection.
  - \* Failure to do so may result in injury or burns due to residual pressure or spillage around the valve.
- (3) In case of using high temperature fluid, do not touch the valve directly bare hands.
  - \* May result in burn.
- (4) Do not supply electric power while the solenoid coil is detached from the product.
  - \* The over current may cause the fire.

#### Caution

- (1) In order to maintain original performance and function, examine daily and personal inspection.
- (2) Solenoid valve shall be disassembled and inspected by qualified person or manufacture.
  - \* Request the treatment to specialized dealer or manufacture in case of any problem.
- (3) When disassembly, the application inside the valve may leak, so catch with container. When disassembly, take out the application inside valve.
- (4) Be sure not to drop down the product. And put over a soft cloth during disassembly to avoid the scratch on the products.
- (5) While re-assembly, tighten all hexagon bolts evenly on each bolt in turn of diagonal position.
- (6) For repairing, be sure to use formal parts. And be sure not to modify the product.
  - \* May results in physical damage or burn by broken of products, leakage of fluids, or abnormal operation.
- (7) In the event of failure, be sure to turn off the electric current source and give and inspection of the products.
  - \* May results in physical damage.
- (8) When finding any defect on the product, follow the guidance from maintenance.
  - \* May cause malfunction.
- (9) When assembling the products, be sure to change into new gasket. The new gasket comes with gasket paste.
  - \* May results in leakage when using old gasket.
- (10) After assembling or re-assembling, perform test working before start operation again. For the contents, refer the article on “7.2 Test Working”.

## 8. 2 Troubleshooting

Problem	Cause	Countermeasure
Valve does not open.	Power is not turned ON.	Check and turn on the power.
	Plunger P is stuck by foreign matter of the piping.	Disassemble and remove the foreign matter. Be sure that the sliding action is smooth.
	Sliding action of plunger P is not smooth because of dents of pipe.	Replace upper parts.
	An incorrect pressure is being used.	Correct the pressure or correct Model.
	Fluid viscosity is 20cSt or more.	Correct viscosity or correct Model.
	Voltage is fluctuating.	Regulate it within the range of $\pm 10\%$ on rating voltage.
	Voltage is incorrect.	Correct the voltage.
Valve does not close.	Scale or Scratch on the plunger P or valve disc.	Disassemble and clean. If scratches exist, replace it.
	Plunger P is stuck by foreign matter of the piping.	Disassemble and remove the foreign matter. Be sure that the sliding action is smooth.
	Sliding action of plunger P is not smooth because of dents of pipe.	Replace upper parts.
	Inlet/outlet is in the opposite direction.	Reinstall correctly.
Abnormal noise is heard.	Hexagon nut clamping the coil is loose.	Tighten it.
	Foreign matter exists at the top of plunger P.	Disassemble and remove the foreign matter.
	An incorrect pressure is being used.	Correct the pressure or correct Model.
	Voltage is incorrect.	Correct viscosity or correct Model.
External leakage	Gasket is damaged or defect of tightening the cover.	Replace the Gasket.

## 8. 3 Disassembly Procedure (Refer to the disassembly drawing)

- (1) Remove the hexagon nut and the coil. Being careful not to lose the washer, O-Ring, etc.
- (2) Loosen the hexagon bolt by 2 to 3mm, and make sure that the internal pressure has been discharged.
- (3) Carefully remove the hexagon bolt and the cover, and then pull out the valve assembly.
- (4) Pay attention to each part not the cover, and then pull out the valve assembly.
- (5) Re-assembly should occur in the reverse order of disassembly procedure described above. When assembling the product, replace to new gasket. Gasket paste is on the new gasket but use as it is.

## 8. 4 Disassembly Drawing

### ■ DP-10/15/10D/15D

( DP-13/13D is shell flange type.  
DP-17/17D is welded flange type. )

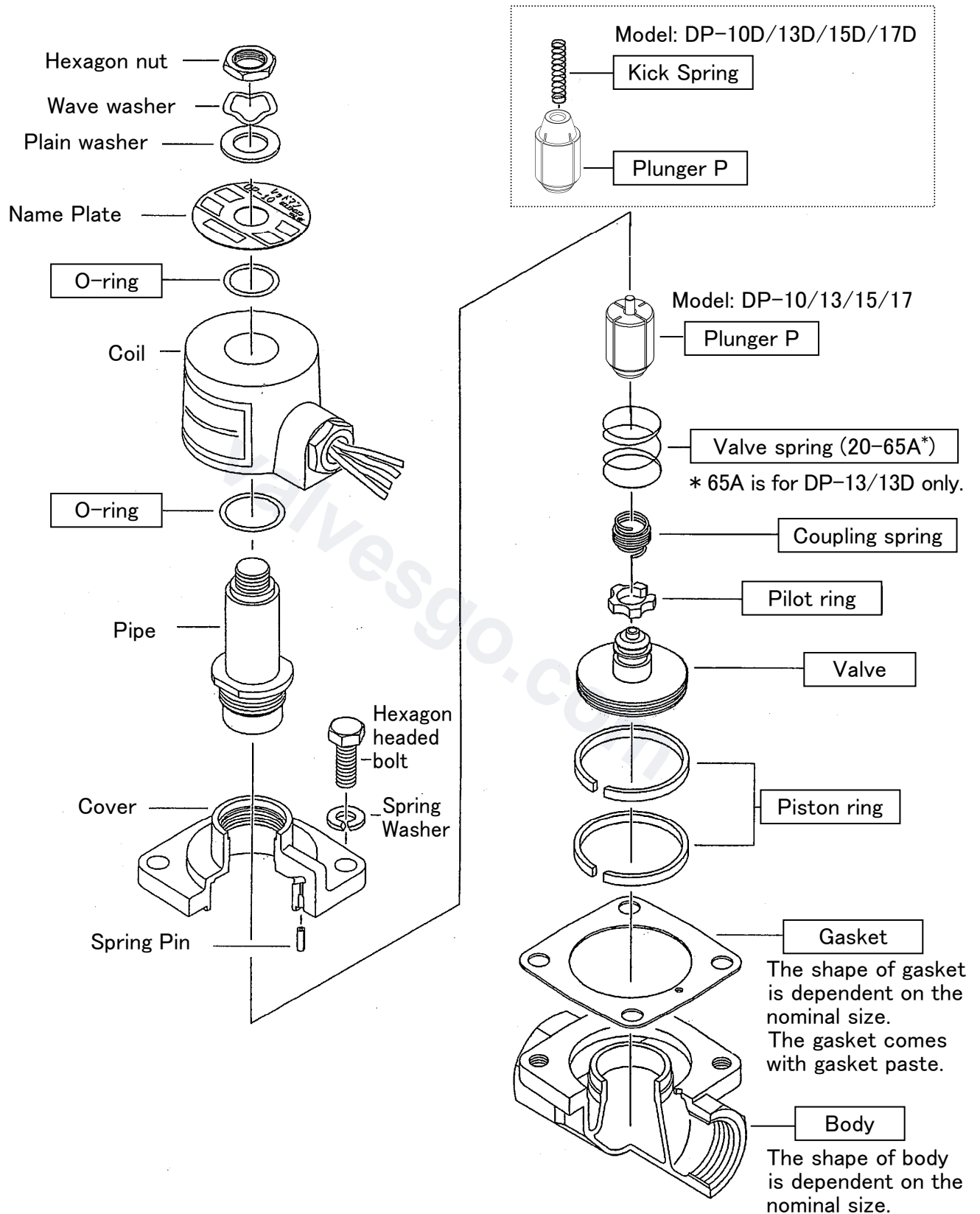

Parts names shown in boxes are consumable items.

■ DP-12/16/12D/16D

( DP-14/14D is shell flange type.  
DP-18/18D is welded flange type. )

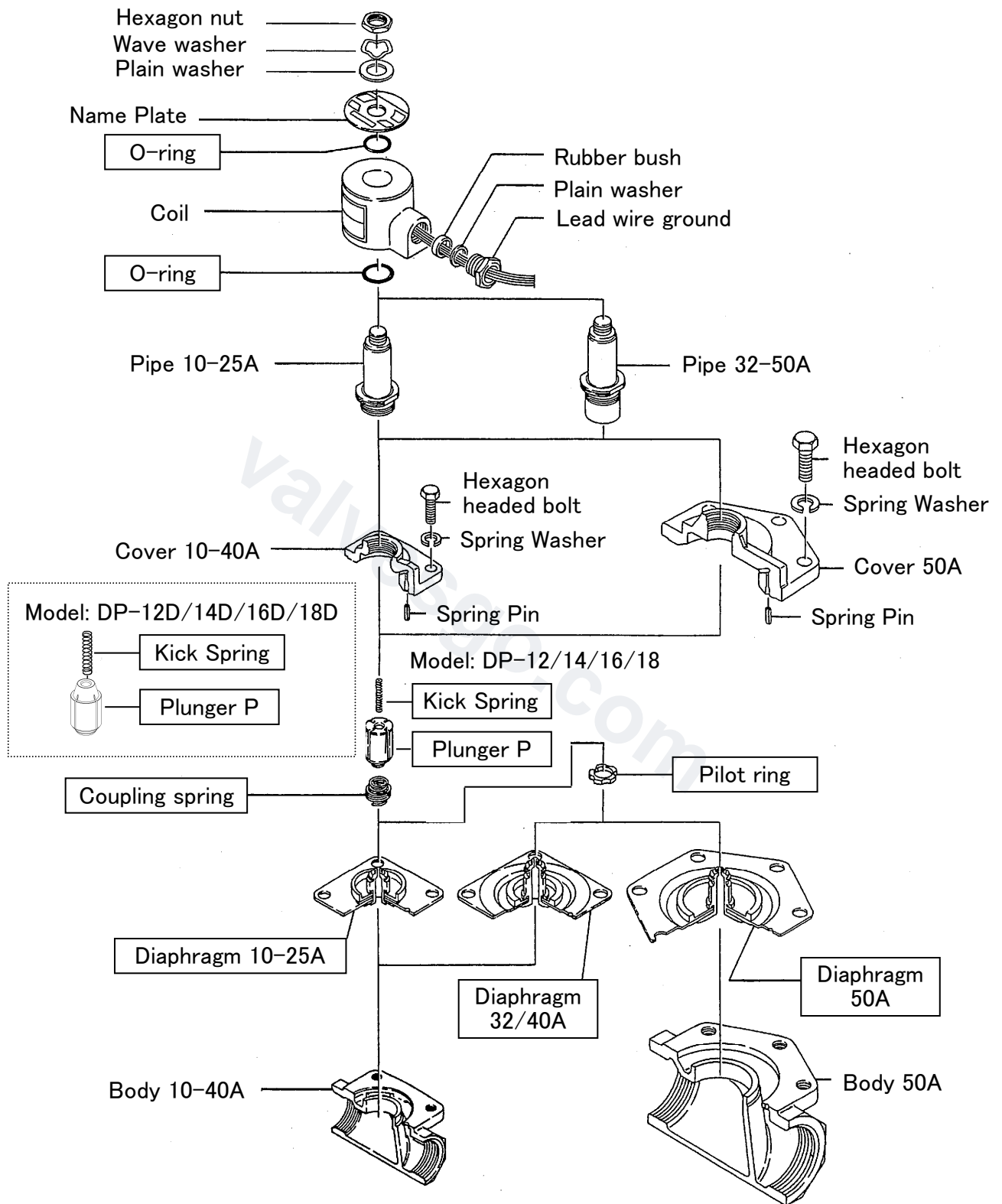

\* Parts names shown in boxes are consumable items.

---

## Warranty Information

---

1. Limited warranty

This product has been manufactured using highly-advanced techniques and subjected to strict quality control. Please be sure to use the product in accordance with instructions on the manual and the label attached to it.

Yoshitake warrants the product to be free from any defects in material and workmanship under normal usage for a period of one year from the date of receipt by the original user, but no longer than 24 months from the date of shipment from Yoshitake's factory.

2. Parts supply after product discontinuation

This product may be subject to discontinuation or change for improvement without any prior notice. After the discontinuation of the product, Yoshitake supplies the repair parts for 5 years otherwise individually agreed.

3. This warranty does not cover the damage due to any of below:

- (1) Valve seat leakage or malfunction caused by foreign substances inside piping.
- (2) Improper handling or misuse.
- (3) Improper supply conditions such as abnormal water pressure/quality.
- (4) Water scale or freezing.
- (5) Trouble with power/air supply.
- (6) Any alteration made by other than Yoshitake.
- (7) Use under severe conditions deviating from the design specifications (e.g. in case of corrosion due to outdoor use).
- (8) Fire, flood, earthquake, thunder and other natural disasters.
- (9) Consumable parts such as O-ring, gasket, diaphragm and etc.

Yoshitake is not liable for any damage or loss caused by malfunction or defect of the product.

# YOSHITAKE

INTERNATIONAL DEPT.

955-5, Miyamae, Irukadeshinden, Komaki, Aichi, 485-0084, Japan

Phone: +81-568-75-4432 Fax: +81-568-75-4763

E-mail: [Intntl@yoshitake.co.jp](mailto:Intntl@yoshitake.co.jp)