



# MODEL DP-200 series Pilot-operated Solenoid Valve

Thank you very much for choosing the Yoshitake's product. To ensure the correct and safe use of the product, please read this manual before use. This manual shall be kept with care for future references.

The symbols used in this manual have the following meanings.

	<b>Warning</b>	This symbol indicates a potentially hazardous situation that, if not avoided, could result in death or serious injury.
	<b>Caution</b>	This symbol indicates a hazardous situation that, if not avoided, may result in minor or moderate injury or may result in only property damage.

## Table of Contents

1. Usage of the Product .....	1
2. Specifications .....	1
3. Dimensions and Weights .....	3
4. Operation .....	5
5. Nominal Size Selection .....	6
5.1 Nominal size selection chart .....	6
5.2 Nominal size selection .....	8
6. Installation .....	8
6.1 Piping example .....	8
6.2 Wiring method .....	9
6.3 Precaution for installation .....	9
7. Operating Procedure .....	11
7.1 Precaution for operation .....	11
7.2 Test working .....	12
8. Maintenance .....	12
8.1 Precaution for maintenance .....	12
8.2 Daily and periodic inspections .....	13
8.3 Periodic replacement of parts .....	14
8.4 Troubleshooting .....	14
8.5 Disassembly .....	15
8.6 Reassembly .....	15
9. Exploded Drawing .....	17
Warranty Information	

# YOSHITAKE

■ EPDT-266d ■

## 1. Usage of the Product

The DP-200 series, solenoid valves of pilot-operated type, are used for automatic on-off control of a fluid flow in combination with remote operated equipments or various control switches.

## 2. Specifications

Model	Normally closed	DP-200	DP-200F
Nominal size		10-50A	15-50A
Structure		Pilot-operated diaphragm type	
Application		Cold and Hot water, Air, N <sub>2</sub> gas, CO <sub>2</sub> gas (dry), Ar gas, Oil (20 cSt or less: equivalent to kerosene and light oil)	
Working pressure		0-1.0 MPa (Unusable under vacuum)	
Min. differential pressure (*1)		0 MPa (0.1 MPa or more is required if the coil set sideways)	
Allowable valve seat leakage		No (by confirming pressure gauge visually)	
Temperature range		5-60°C (no freeze condition)	
Ambient temperature		50°C or less (no freeze condition)	
Installation posture (*1)		Vertical or horizontal installation ( within 90 degrees from upward position of the coil)	
Material	Body	Cast bronze	
	Cover		
	Diaphragm	NBR	
Connection		JIS Rc screwed	JIS 10K FF flanged

- \*1: See Table 1.
- Available with rubber material FKM for the diaphragm and pilot valve.
- Model numbers of the products complying with the Japanese Water Works Law are DP-200-N and DP-200F-N.
- When using the solenoid valve to pilot piping of constant water level valve, select direct type (DD-3-8N).

Table 1 Min. differential pressures and installation postures

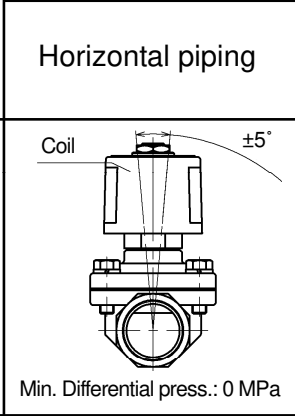
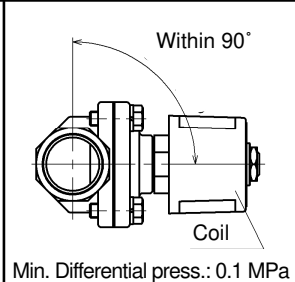
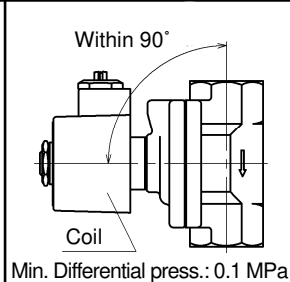
	Horizontal piping	Vertical piping
Coil set upward	 <p>Min. Differential press.: 0 MPa</p>	/
Coil set sideways	 <p>Min. Differential press.: 0.1 MPa</p>	 <p>Min. Differential press.: 0.1 MPa</p>

Performance and specifications of coil

Rated voltage	AC 100 / 200 V selective type	AC 110 / 220 V selective type
	50 / 60 Hz common	
Allowable fluctuation	Rated voltage -5% to +10%	
Rated current	0.42 / 0.21 A	0.38 / 0.19 A
Starting current	1.64 / 0.82 A	1.48 / 0.74 A
Insulation class	Insulation class H	
Protective structure	Dust tight, Splash proof	
Ingress protection code	IP64 (JIS C0920)	
Insulation resistance	50 MΩ and more / 500 V megger	
Withstand voltage test	1500 V/min	

- Available with coil equipped with a terminal box (made of plastic) upon request.

	<p><b>Caution</b> Please confirm that the indications on the product correspond with the specifications of the ordered product model before use. * If they are different, do not use the product and contact us.</p>
---	--

valvesgo.com

### 3. Dimensions and Weights

- Connection: JIS Rc screwed (Model: DP-200)

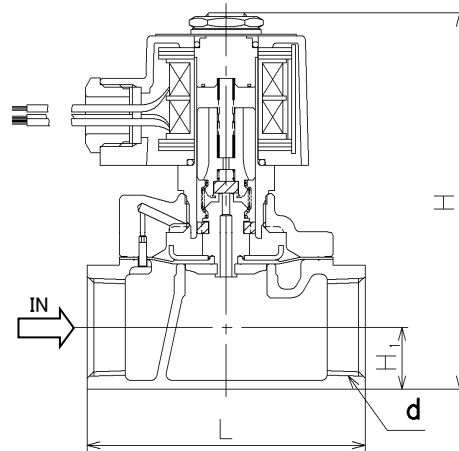

(mm)

Nominal size	d	L	H <sub>1</sub>	H	Weight (kg)
10A	Rc 3/8	70	14.5	114	1.1
15A	Rc 1/2	70	14.5	114	1.1
20A	Rc 3/4	80	17.5	121	1.3
25A	Rc 1	95	21.0	128	1.7
32A	Rc 1 1/4	110	26.0	150	2.5
40A	Rc 1 1/2	120	29.5	157	3.1
50A	Rc 2	140	36.5	172	5.0

- Connection: JIS 10K FF flanged (Model: DP-200F)

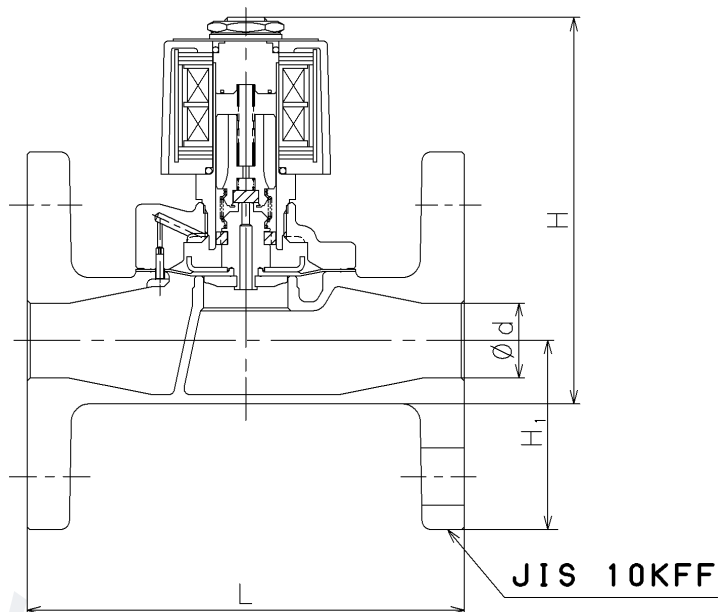

(mm)

Nominal size	d	L	H <sub>1</sub>	H	Weight (kg)
15A	15	120	47.5	147	2.7
20A	20	130	50.0	153	3.3
25A	25	145	62.5	169	4.8
32A	32	160	67.5	192	6.6
40A	40	170	70.0	198	7.3
50A	50	195	77.5	213	10.0

---

## 4. Operation

---

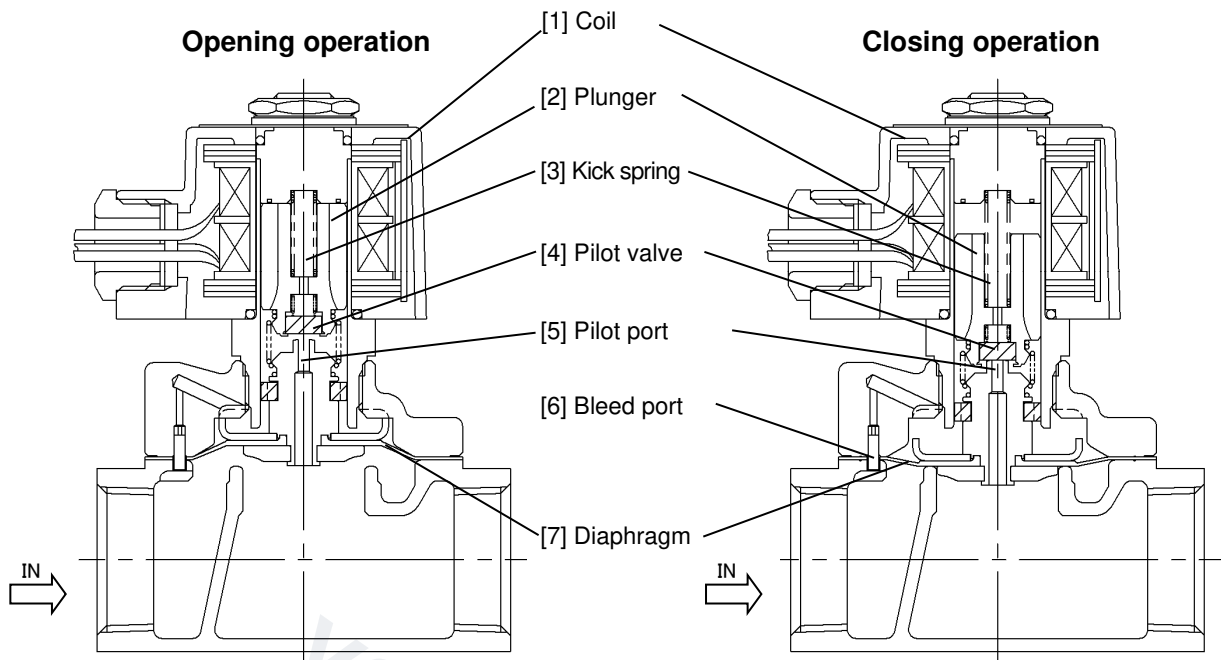

(1) Opening operation (Power ON)

When the power is turned ON, the coil [1] is excited and pulls up the plunger [2], to open the pilot valve [4]. Next, the pressure at the upper part of the diaphragm [7] drops since it flows to the outlet through the pilot port [5]. The diaphragm [7] is then lifted up to open position by the inlet pressure.

(2) Closing operation (Power OFF)

When the power is turned OFF, the coil [1] excitation is canceled and the plunger [2] drops down by force of the kick spring [3], to close the pilot valve [4]. The pressure at the upper part of the diaphragm [7] rises due to the incoming inlet pressure from the bleed port [6] which is communicated with the inlet. With the support of the kick spring [3], this makes the diaphragm [7] pushed down to closed position.

## 5. Nominal Size Selection

### 5.1 Nominal size selection chart

■ For air

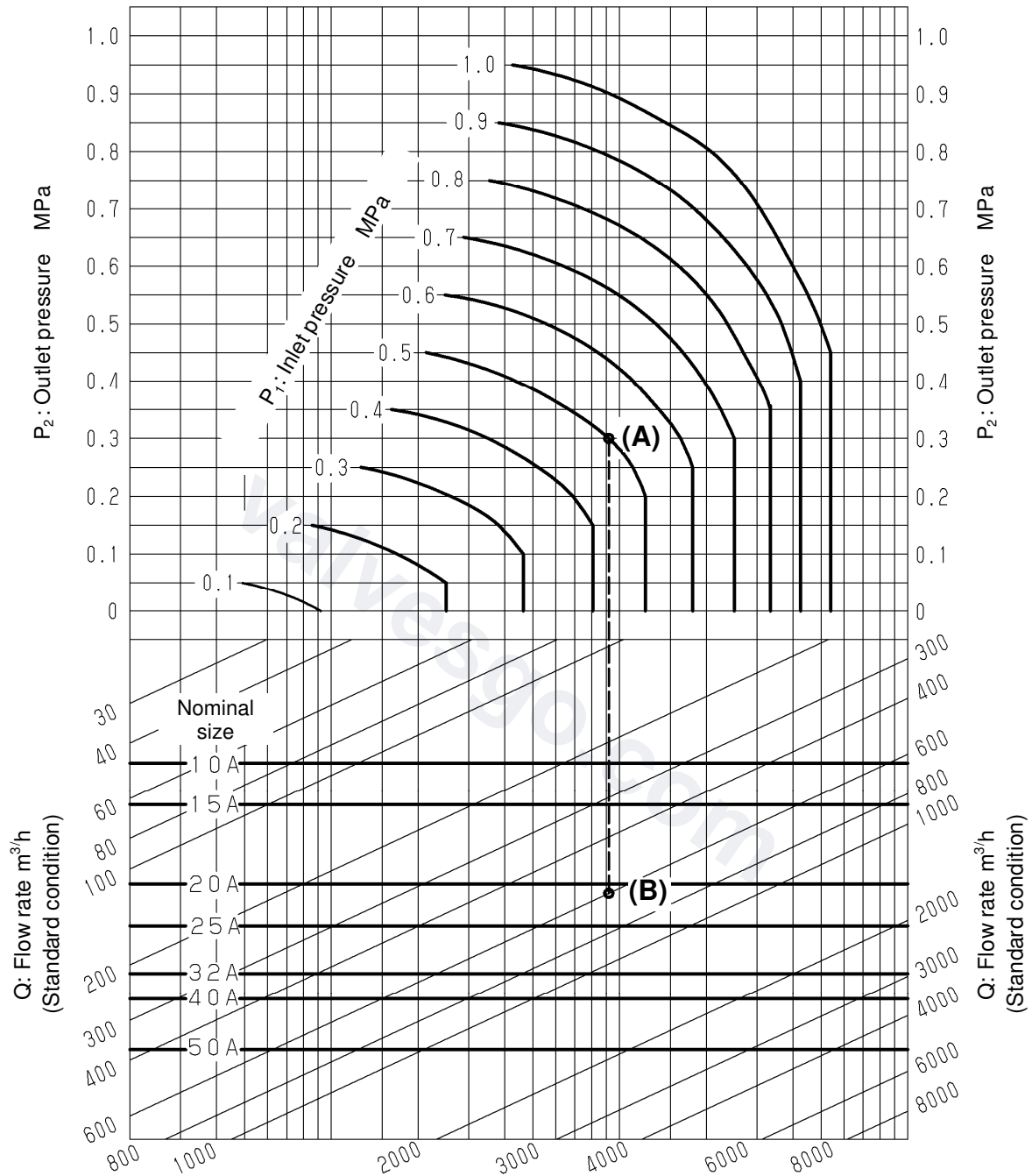

#### [How to use the chart]

When selecting the nominal size of a solenoid valve whose inlet pressure ( $P_1$ ), outlet pressure ( $P_2$ ) and air (20°C) flow rate ( $Q$ ) are 0.5 MPa, 0.3 MPa and 600  $m^3/h$  (standard condition), respectively, first find intersection point (A) of  $P_1 = 0.5 MPa$  and  $P_2 = 0.3 MPa$ . Trace down vertically from this intersection point (A) to find intersection point (B) with  $Q = 600 m^3/h$  (standard condition). Since this intersection point (B) lies between nominal sizes 20 A and 25A, select the larger one, 25A.

■ For water

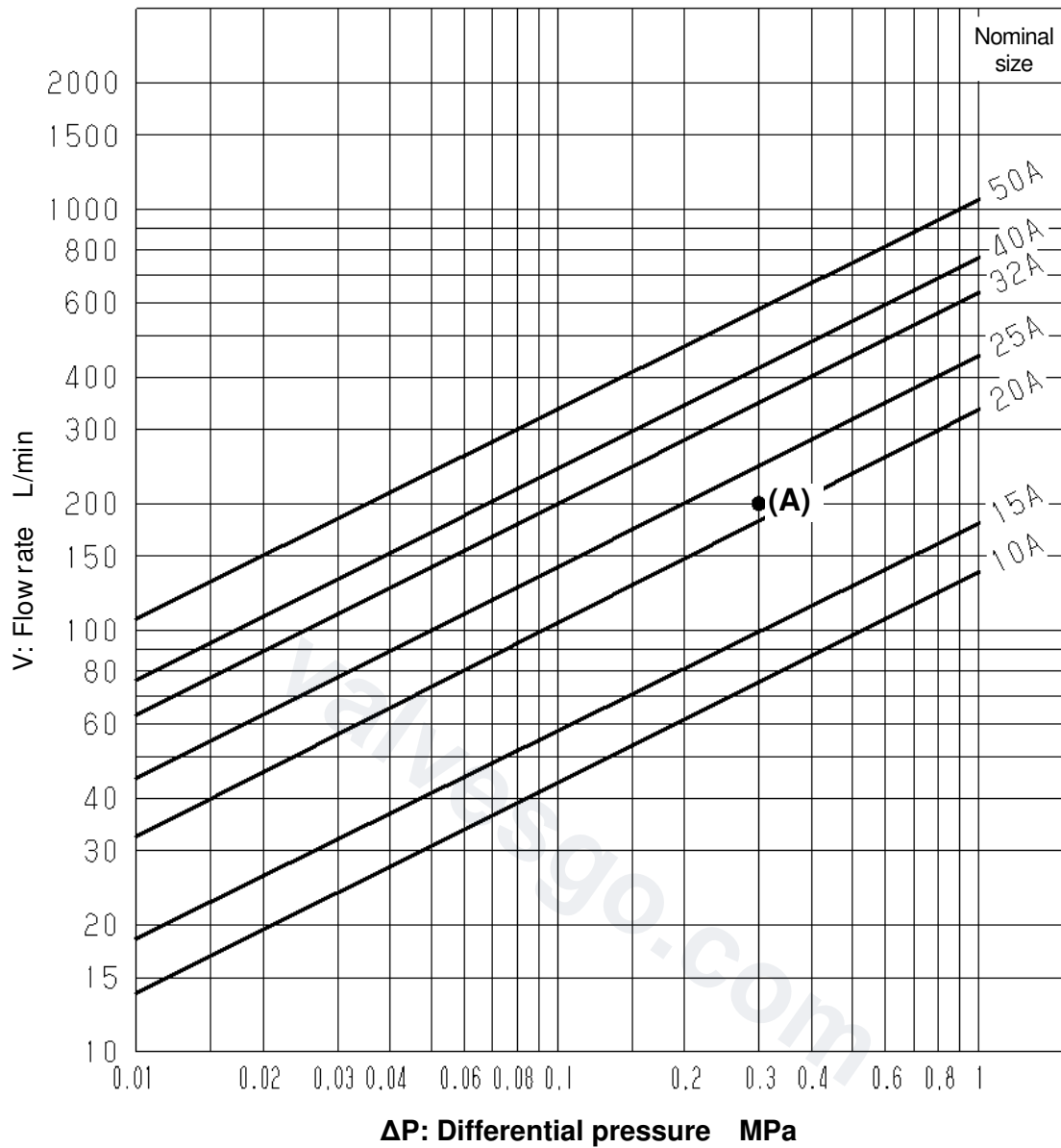

**[How to use the chart]**

When selecting the nominal size of a solenoid valve whose inlet pressure ( $P_1$ ), outlet pressure ( $P_2$ ) and flow rate ( $V$ ) are 0.6 MPa, 0.3 MPa and 200 L/min, respectively, first find intersection point (A) of the differential pressure before and after the valve [ $\Delta P = 0.6 - 0.3 = 0.3$  MPa] and  $V = 200$  L/min. Since this intersection point (A) lies between nominal sizes 20A and 25A, select the larger one, 25A.

## 5.2 Nominal size selection

- Cv value calculation formula

<Liquid>

$$Cv = \frac{0.365V\sqrt{G}}{\sqrt{\Delta P}}$$

<Air>

$$\text{When } P_2 > \frac{P_1}{2} \quad Cv = \frac{Q}{2940} \sqrt{\frac{(273+t)G}{\Delta P(P_1 + P_2)}}$$

$$\text{When } P_2 \leq \frac{P_1}{2} \quad Cv = \frac{Q\sqrt{(273+t)G}}{2550P_1}$$

Cv: Cv value of each nominal size

$\Delta P$ :  $P_1 - P_2$  [MPa]

Q: Max. gas flow rate [m<sup>3</sup>/h (standard condition)]

G: Specific gravity (relative to air for gas,  
or relative to water for liquid)

V: Max. liquid flow rate [m<sup>3</sup>/h]

P<sub>1</sub>: Inlet pressure [MPa·A]

P<sub>2</sub>: Outlet pressure [MPa·A]

- Cv value

Nominal size	10A	15A	20A	25A	32A	40A	50A
DP-200·200F	3 (1.2)	4 (1.7)	7.5 (3.2)	10 (4.6)	14 (5.5)	17 (6.5)	24 (9.5)

- Cv values in parentheses are values when differential pressure is 0.01 MPa or less.

## 6. Installation

### 6.1 Piping example

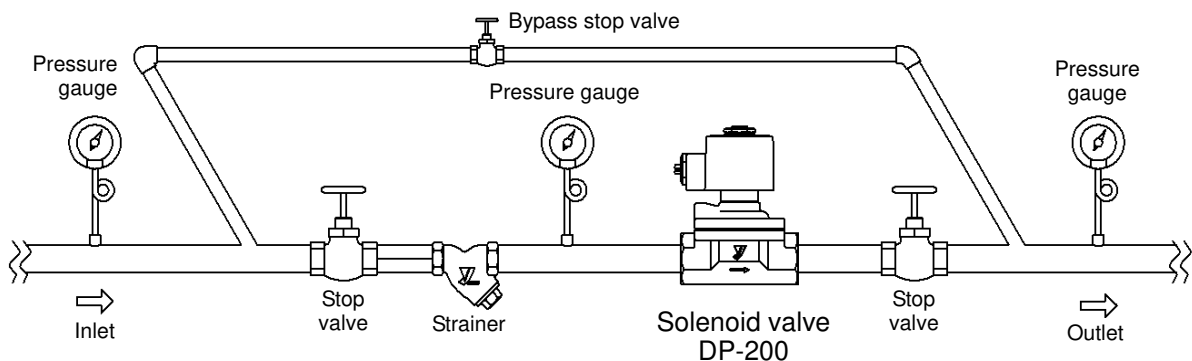

\* Differential pressure of at least 0.1 MPa is required to actuate the product when the coil is set sideways.

\* Use the stop valves at the inlet and the outlet of the product at full open condition.

## 6.2 Wiring method

1. Wiring method differs between the voltages, AC 100 / 110 V and 200 / 220 V. Bind the lead wires of the coil according to the instruction on the label attached to the coil.
2. In order to prevent disconnection or insulation failure, avoid unnecessarily pulling the lead wires or subjecting them to excessive load while wiring or use.
3. Use electric wires which have a core of 0.75 mm<sup>2</sup> or more.
4. Install a fuse (3A) to protect the electric circuit. In addition, if the product is used in a fuel supply system, install a circuit protector of a rated capacity shown in the following.
  - Rated voltage 100 / 110 V: 0.5 A circuit protector
  - Rated voltage 200 / 220 V: 0.3 A circuit protector
5. When using a terminal box, do not rotate it to change its posture.
  - \* Failure to follow this notice may cause disconnection or insulation failure.

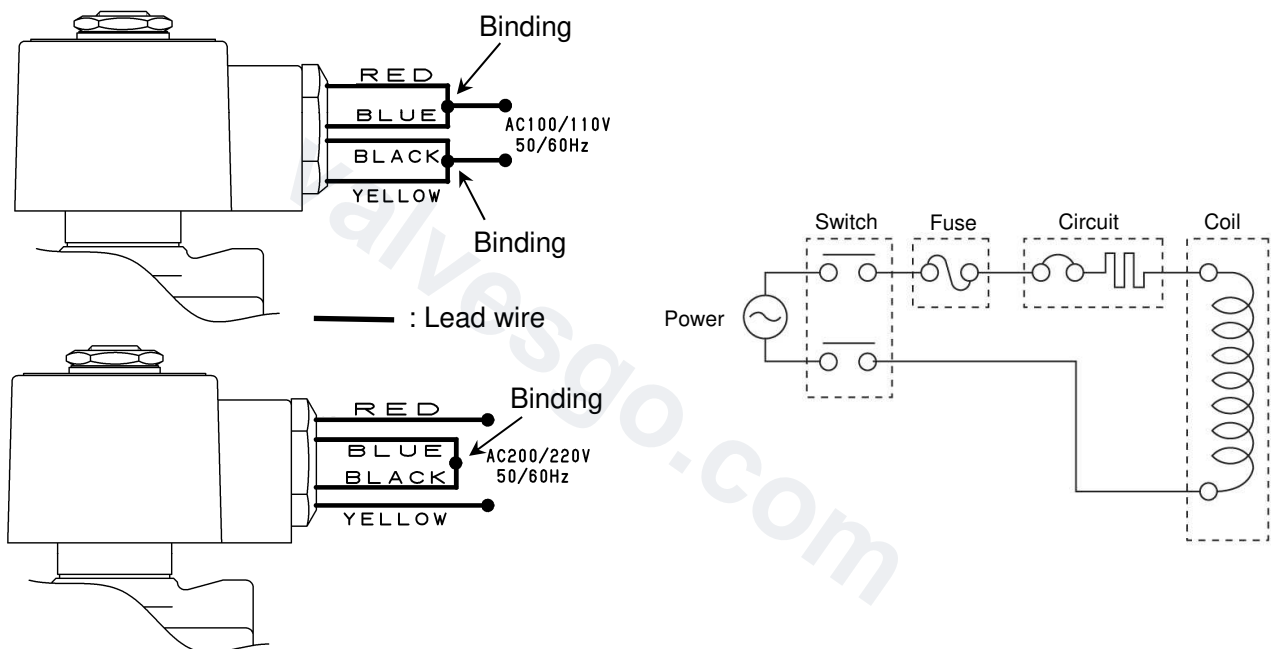

## 6.3 Precaution for installation

### Warning

Electric wiring work must be done by experienced professional.

1. If there is a risk of death, bodily injury or damage to property at the time of malfunction of the product, be sure to install a suitable safety device that controls fluid flow interception/release or sounds an alarm.
2. The product cannot be used as an emergency shutoff valve.
  - \* The product is not designed as a safety valve such as an emergency shutoff valve. If the product is applied to a system that needs safety measures, install other equipment besides the product to ensure the safety.
3. The product is not explosion-proof. Do not use it in the area or ambience where explosive gases accumulate.
  - \* Using the product under the said conditions may cause fire.
4. Connect the cables only after confirming that no power is supplied.
  - \* Failure to follow this notice may cause an electric shock.
5. Connect the cables according to the instructions after confirming the rated voltage.
  - \* Erroneous cable connection may cause an electric shock or fire.
6. Do not supply electric power to the coil while it is detached from the valve.
  - \* Failure to follow this notice may result in coil burnout or fire due to an overcurrent.

 **Caution**

1. When installing the product with the coil set sideways, make sure that the differential pressure (the minimum differential pressure to operate the valve) between the inlet and the outlet is 0.1 MPa or more (see Table 1 on Page 1).  
\* Failure to follow this notice may result in an abnormal operation.
2. Though the product can be installed at any angle between vertical and horizontal, it cannot be installed upside-down (see Table 1 on Page 1).  
\* Failure to follow this notice may result in an abnormal operation.
3. Before connecting piping to the product, remove foreign substances and dirt inside the piping.  
\* Failure to follow this notice may keep the product from functioning properly.
4. When installation, check the direction of the product so that the fluid flowing and the arrow marked on the product are in the same direction.  
\* Failure to follow this notice may keep the product from functioning properly (the valve cannot close).
5. Make sure to connect a strainer (80–100 mesh) to the inlet of the product.  
\* Failure to follow this notice may keep the product from functioning properly.
6. Do not apply excessive load, torque or vibration to the product.  
\* Failure to follow this notice may result in drastically shortened service life.
7. Secure enough space required for disassembly or removal of the product at maintenance or inspections.  
\* Failure to follow this notice hampers maintenance and inspections.

■ Minimum space for disassembly or removal

Model: DP-200 · 200F (mm)

Nominal size	L1	L2,L3,L4
10-25A	200	150
32-50A	250	200

L1: Required space for removal/disassembly of the coil

L2, L3, L4: Required space for replacement of the product

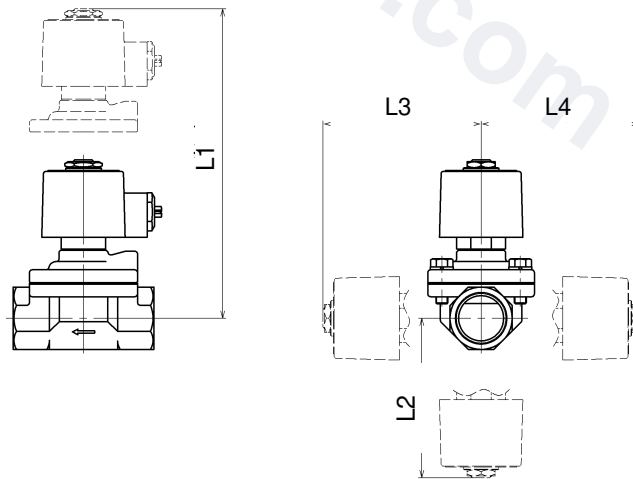

8. If the product is used outdoors, place protective covers or guards above the product in order to avoid exposure to water.  
\* Failure to follow this notice may cause an electric leakage.
9. Do not apply insulation to the solenoid coil.  
\* Failure to follow this notice may cause the coil burn out with abnormal temperature rise, which causes malfunction of the product.
10. When the product is used in a facility which cannot stop operating, install a bypass line with a bypass stop valve.  
\* Use the bypass line while troubleshooting or disassembling the product so that the facility can keep operating.

11. Before piping, remove foreign substances and note that seal materials must not flow into the inside of the valve and piping.  
\* Foreign substances may cause valve seat leakage and malfunction.
12. Deterioration of rubber parts may be accelerated by influence of pipe seal material.
13. When using the product under the conditions where the outlet pressure can accidentally become higher than the inlet pressure, install a check valve at the outlet side to prevent backflow.  
\* Failure to follow this notice may cause backflow even during the solenoid valve is closed.
14. In case of a possible frozen line, take proper measures to remove water inside the piping or equip the product with insulating materials.  
\* Freezing may damage the product. However, do not insulate the coil.
15. When installing the product in the piping, do not grip and turn it with a tool.  
\* Failure to follow this notice may damage the coil.
16. Do not pull the lead wires or hold the wire to lift and carry the product.  
As for the terminal box attached type, do not pull the terminal box or carry the product by holding the terminal box only.  
\* Failure to follow this notice may damage the coil (or the terminal box).
17. Make the lead wires connected to the coil long enough so that the coil is easily dismantled or replaced when required.
18. Band and support the lead wires of the coil to avoid their contact with workers or other equipment and to avoid subjecting the wires to its own weight and tension.
19. Install the product with the coil faced upward if the pressure difference between the inlet and the outlet sides of the product can accidentally become 0 MPa at least temporarily (see the table 1 on Page 1).  
\* Failure to follow this notice may keep the product from functioning properly.
20. When an automatic control valve is installed at the inlet or outlet side of the product, keep more than 3 meters between them.  
\* Failure to follow this notice may result in malfunction of the product due to differential pressure fluctuation caused by fluctuation in inlet pressure at the time of the product actuation.
21. The nominal size of piping at the product inlet side should not be smaller than that of the product (do not reduce the inlet pipe diameter).  
Additionally, use the stop valves at the inlet and the outlet sides of the product at full open condition (see "6.1 Piping example" on Page 7).  
\* Failure to follow this notice may result in malfunction of the product due to differential pressure fluctuation caused by fluctuation in inlet pressure at the time of the product actuation.
22. If the product is in a closed piping condition, the fluid inside the pipe will expand in volume due to the rise in fluid temperature and product may be damaged.
23. Sticky fluids may cause parts to stick and lead to malfunction.
24. Avoid connection of dissimilar metal piping which will cause a galvanic potential difference because the product or the parts may be corroded.
25. Select the product considering conditions of use such as operation frequency and durability.

---

## 7. Operating Procedure

---

### 7.1 Precaution for operation



#### Warning

1. Do not touch the coil with bare hands while it is energized.  
\* Failure to follow this notice may result in burns.
2. Do not touch the product with bare hands when the product is used for hot fluid.  
\* Failure to follow this notice may result in burns.
3. Before leading fluid, make sure that there is no danger when the fluid flows to the end of piping.  
\* The fluid outflow may cause physical damage.  
\* The hot fluid, if spouted out, may scald your skin.



## Caution

1. When the product is newly installed or left without being operated for a long time, perform test working before starting operation.
2. Completely discharge the fluid inside of the product and line before leaving the product not operated for a long time.  
\* Failure to follow this notice may cause malfunction due to rust inside of the product and lines, or result in damage due to freezing.
3. Sudden application of pressure to the product may open the valve instantly and cause leakage.
4. Since the product is used with AC voltage, it may produce a buzzing sound depending on the conditions of use.

## 7.2 Test working

Before performing test working, be sure to close the stop valves installed at both the inlet and the outlet sides of the product and remove foreign substances and scale completely by flushing the bypass line.

1. Before leading the fluid into the product, switch it on and off a few times and confirm that clicking sound caused by the plunger when the coil turns on.
2. Fully open the stop valve at the outlet side.
3. With the product at open position, open the stop valve at the inlet side gradually and confirm that the fluid flows to the end of the piping.
4. Gradually close the stop valve at the outlet side, and confirm the fluid does not leak from the product or connection parts of the piping joints.
5. With the product at closed position, fully open the stop valves at both the inlet and the outlet sides.
6. Switch on and off a few times to confirm that the product opens and closes properly.
7. With the product at closed position, confirm there is no leakage at the end of the piping.

In case of any abnormal condition observed during test working, refer to “8. Maintenance” to take proper measures and treatment.

---

## 8. Maintenance

---

Since most of the troubles with the product are caused by foreign substances inside of the piping, care should be taken. Note that any repairs caused by foreign substances or scales are subject to a charge even during the warranty period.

### 8.1 Precaution for maintenance



## Warning

Disassembly and maintenance must be done by experienced professional or valve manufacturer.

1. Confirm that no power is supplied before disassembling or maintenance.  
\* Failure to follow this notice may cause an electric shock.
2. Completely discharge the pressure inside of the product, line and equipment before disassembling or maintenance and cool down the product till it can be touched with bare hands in the case of high-temperature fluid.  
\* Failure to follow this notice may result in injury or burns due to residual pressure.
3. Do not supply electric power to the coil while it is detached from the valve.  
\* Failure to follow this notice may result in coil burnout or fire due to an overcurrent.



## Caution

1. Conduct daily/periodic inspections in order to maintain the optimal performance of the product.
2. Be careful not to drop the product at the time of disassembling, and put the disassembled parts on soft cloth in order to avoid scratch and damage.  
\* Failure to follow this notice may keep the product from functioning properly.
3. When repairing, do not use the parts other than the dedicated parts manufactured by Yoshitake. Do not modify the product.  
\* Failure to follow this notice may cause damage to the product, or may result in scalds or injury due to blow-off or malfunction.
4. In the event of troubles, close the stop valves and turn off the power before inspection.  
\* Failure to follow this notice may result in bodily injury.
5. If any defect is found on the product during the daily/periodic inspections, be sure to contact the local distributor and follow its instructions.
6. After re-assembling, perform test working before starting operation again.
7. While disassembling, the fluid leaks from inside of the product. Set a container to collect the fluid. Completely discharge the fluid inside of the product prior to disassembly.
8. When reassembling, connect all the parts securely. Tighten the bolts uniformly in diagonal positions to prevent uneven tightening.

## 8.2 Daily and periodic inspections

Conduct daily and periodic inspection/replacement in order to maintain the optimal performance of the product.

### ■ Daily inspection (once a day)

Item	How to inspect	Trouble and remedy	
Working conditions	Check that the valve opens when switched on, and closes when switched off.	The valve does not open. (Fluid does not flow.)	See "8.4 Troubleshooting" on Page 13.
		The valve does not close. (Fluid flow does not stop.)	
Outside leakage	Inspect the product visually.	See "8.4 Troubleshooting" on Page 13.	

### ■ Periodic inspection (once a year: Add the following items to the above daily inspection items)

Item	How to inspect	Trouble and remedy	
Seal seat surfaces of the body and the diaphragm	Disassemble the product and visually inspect the parts.	Seal seat surface of the diaphragm is damaged.	Replace the diaphragm complete set.
		Seal seat surface of the body is damaged.	Replace the product.
Seal seat surface and sliding surface of the plunger	Disassemble the product and visually inspect the parts.	Seal seat surface, sliding surface or both are damaged.	Replace the diaphragm complete set.

### 8.3 Periodic replacement of parts



#### Caution

Replace the following parts when the time below comes in order to maintain the optimal performance of the product.  
For replacement parts, replacement time differs according to frequency or condition of use. Standard times for replacement are shown in the table below.

#### ■ Part replacement

Part	Time for replacement
Diaphragm complete set*	Per 150,000 actuations
Coil	Per 4 years

\* marked parts are replaced as diaphragm complete set.

### 8.4 Troubleshooting

Trouble	Cause	Remedy
The valve does not open. (Fluid does not flow.)	1. Strainer installed at the inlet side of the product is clogged.	1. Clean the strainer.
	2. Plunger a'ssy is stuck with foreign substances in the piping.	2. Disassemble the product and remove foreign substances. Make sure that the sliding action is smooth.
	3. The pilot port gets stuck with foreign substances.	3. Replace the diaphragm complete set with a new one.
	4. Fluid pressure exceeds the specified working pressure.	4. Adjust the fluid pressure to the appropriate level.
	5. Fluid viscosity exceeds 20 cSt.	5. Adjust the fluid viscosity to the appropriate level.
	6. No electric conduction (trouble with electric circuit).	6. Check the power supply and voltage.
	7. Wires of coil not bound proper for the applied voltage.	7. Wire the coil properly for the applied voltage. If the trouble still exists, replace the coil with a new one.
	8. Voltage fluctuates widely.	8. Adjust the electric circuit to regulate the voltage within the allowable fluctuation.
	9. Coil specifications do not match with the applied voltage.	9. Replace the coil with a new one proper for the applied voltage.
	10. Coil burned out with abnormal temperature rise caused by use in high ambient temperature condition or in insulated condition, etc.	10. Use the product in ambient temperature lower than that indicated in "2. Specifications." Additionally, do not insulate the coil. Under such condition, replace the coil with a new one.
	11. Coil burned out due to excess current.	11. Replace the coil. Make sure that the applied voltage is within the allowed range of voltage fluctuation.
The valve does not close. (Fluid flow does not stop.)	1. Plunger a'ssy or the diaphragm is stuck with foreign substances or get damaged.	1. Disassemble the product and remove foreign substances. Replace the diaphragm complete set with a new one if any damage is observed.
	2. Plunger a'ssy is stuck with foreign substances in the piping.	2. Disassemble the product and remove foreign substances. Make sure that the sliding action is smooth.
	3. Inlet/outlet of the product is installed in the opposite direction of the fluid flow.	3. Reinstall the product correctly.
	4. Bypass stop valve is kept open.	4. Close the bypass stop valve.
	5. The differential pressure is less than 0.1 MPa when the coil is set sideways.	5. Adjust the differential pressure to be 0.1 MPa or more. If the minimum differential pressure is not obtained, install the product to a horizontal piping with the coil faced upward.
	6. The bleed port (on the body) is obstructed.	6. See 3 in "8.6 Reassembly" on Page 15.
	7. The spring pin (on the cover) is obstructed.	7. Replace the cover complete set with a new one.
	8. Electricity is kept conducted.	8. Check the power supply.
The product vibrates.	1. There is a constricted part of piping just in front of the inlet of the product.	1. See 19 and 20 in 6.3 "Precaution for installation" on Page 10.
	2. Gas is commingled in the liquid. (When the applied fluid is liquid.)	2. Avoid commingling of gas.

Trouble	Cause	Remedy
Abnormal sound is heard.	1. Nut clamping the coil is loosened.	1. Retighten the nut with the specified torque 15N·m.
	2. Foreign substances exist on the internal surface of the pipe or at the top surface of plunger assy.	2. Disassemble the product and remove foreign substances. If the foreign substances cannot be removed, replace the cover complete set and diaphragm complete set with new ones.
	3. Fluid pressure exceeds the specified working pressure.	3. Adjust the fluid pressure to the appropriate level.
	4. Voltage applied to the coil is not proper.	4. Check the voltage.
External leakage is observed.	1. Pipe is loosened.	1. Replace the cover complete set with a new one.
	2. The bolt is loosened.	2. Retighten it with the specified torque.
	3. The diaphragm is damaged.	3. Replace the diaphragm complete set with a new one.

### 8.5 Disassembly (See “9. Exploded Drawing” on Page 16.)

- Loosen the nut (nominal size: 19 mm) on the top of the coil and remove the coil. Pay attention not to lose the small parts such as washers and O-ring.
- Loosen the bolts by 2 to 3 mm and check that no residual pressure is detected.

■ Nominal size of bolt

Nominal size of the product	10-20A	25-32A	40-65A
Nominal size of bolt	10 mm	13 mm	17 mm

- Remove the bolts. Remove the cover complete set and kick spring, then remove the diaphragm complete set. Pay attention not to lose the kick spring.
- Pay attention not to have the disassembled parts damaged, deformed or lost.

### 8.6 Reassembly (See “9. Exploded Drawing” on Page 16.)

Reassemble the product in reverse order of disassembly with paying attention to the following events.

- Installation of the diaphragm complete set to the cover complete set.  
Insert the diaphragm complete set with the kick spring to the cover complete set.

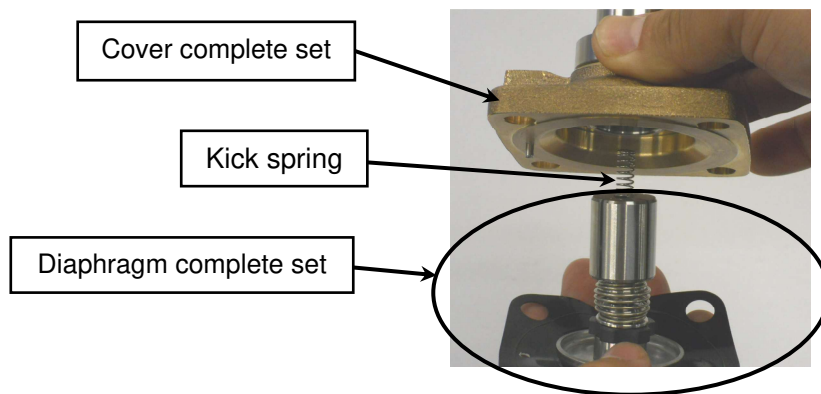

- Operation check of the diaphragm complete set  
Push the diaphragm and check that it moves smoothly.\* If the diaphragm is not moved or lacks movement or is lumbering even being pushed, remove the diaphragm complete set from the cover complete set. If the kick spring drops off, the product does not operate normally. Go back to 1 and install the parts again.

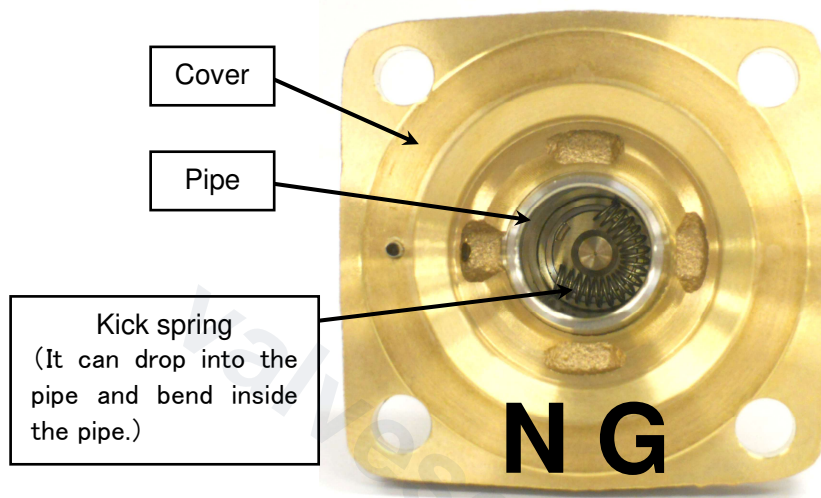
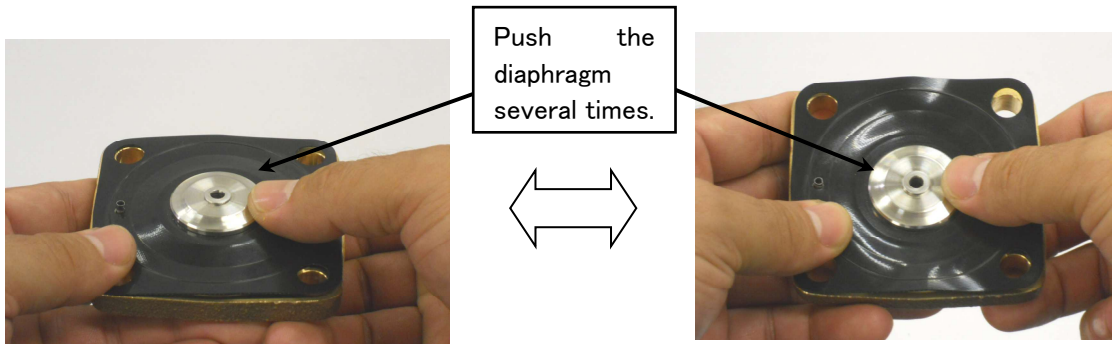

The kick spring drops off the plunger (Bad example: abnormal condition)

- Installation of the cover complete set (the diaphragm complete set with the kick spring) to the body  
When installing, insert the spring pin to the bleed port (pin hole).

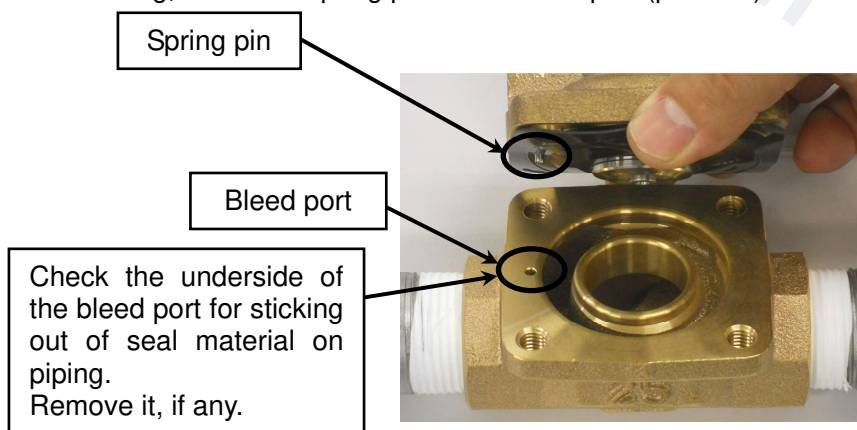

- Fasten the cover complete set to the body with the bolts, using the torque specified below. Be sure to evenly tighten each bolt.

■ Tightening torque

Nominal size	Tightening torque (N·m)
10-20A	10
25A, 32A	12
40A, 50A	15

## 9. Exploded Drawing

- DP-200  
(The DP-200F is flanged type.)

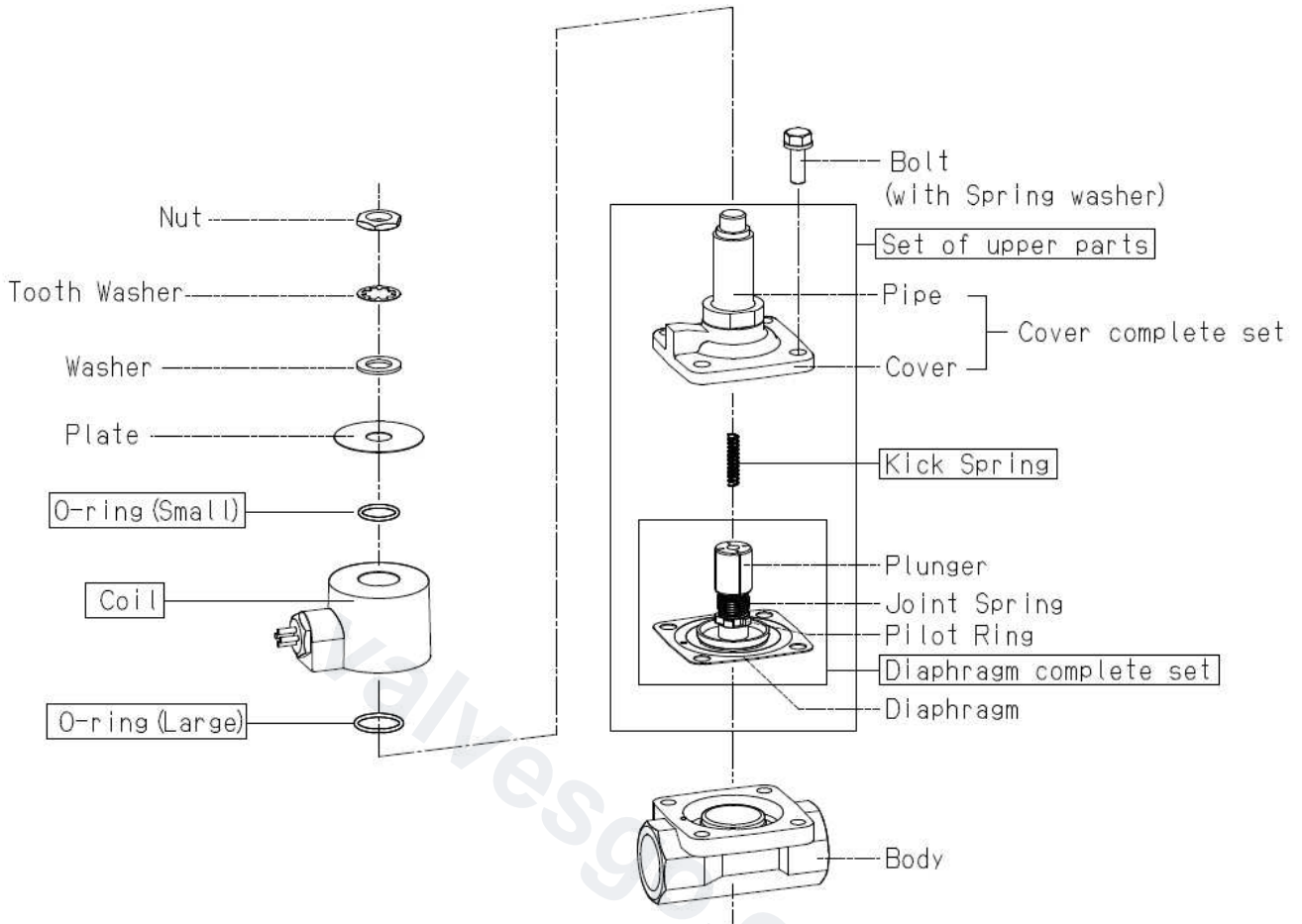

The parts name shown in the rectangle boxes are available as consumable supply.

---

## Warranty Information

---

1. Limited warranty

This product has been manufactured using highly-advanced techniques and subjected to strict quality control. Please be sure to use the product in accordance with instructions on the manual and the label attached to it.

Yoshitake warrants the product to be free from any defects in material and workmanship under normal usage for a period of one year from the date of receipt by the original user, but no longer than 24 months from the date of shipment from Yoshitake's factory.

2. Parts supply after product discontinuation

This product may be subject to discontinuation or change for improvement without any prior notice. After the discontinuation of the product, Yoshitake supplies the repair parts for 5 years otherwise individually agreed.

3. This warranty does not cover the damage due to any of below:

- (1) Valve seat leakage or malfunction caused by foreign substances inside piping.
- (2) Improper handling or misuse.
- (3) Improper supply conditions such as abnormal water pressure/quality.
- (4) Water scale or freezing.
- (5) Trouble with power/air supply.
- (6) Any alteration made by other than Yoshitake.
- (7) Use under severe conditions deviating from the design specifications (e.g. in case of corrosion due to outdoor use).
- (8) Fire, flood, earthquake, thunder and other natural disasters.
- (9) Consumable parts such as O-ring, gasket, diaphragm and etc.

Yoshitake is not liable for any damage or loss caused by malfunction or defect of the product.

**YOSHITAKE** 