

EB-11,12

Bellows

Sleeve

Ball

Single type

Double type

PTEE

Copper pipe

■Features

1. Control ring is provided for the purpose of reinforcement against internal pressure and equalization of bellows expansion.
2. No need for retightening and replacement due to aging since packing is not used. Easy to maintain and manage.
3. Simple structure since the flange, short pipe and bellows are united.
4. Outer pipe is attached in order to protect the bellows from damage due to external impact.
5. Stainless steel inner pipe is attached in order to prevent fluid pressure loss, vibration, impact, corrosion, etc.
6. Stainless steel made wetted parts offer high resistance to corrosion and ensures distinguished durability.

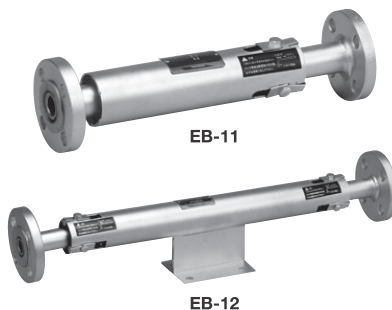

■Specifications

Model	EB-11	EB-12
Application	Steam, Air, Cold and hot water, Oil, Other non-dangerous fluids	
Maximum pressure	2.0 MPa	
Max. temperature	220°C	
Max. axial extension	35 mm (Expansion 10 mm Compression 25 mm)	70 mm (Expansion 20 mm Compression 50 mm) *
Material	Outer pipe	Carbon steel
	Bellows, inner pipe	Stainless steel (SUS316L)
	Connection	JIS 20K RF flanged

* Expansion of one side from the centering anchor base is 10 mm and compression is 25 mm.

· Available with nominal size from 300A to 450A. (Single type: EB-7, Double type: EB-8)



EB-8

■ Dimensions (mm) and Weights (kg)

· EB-11

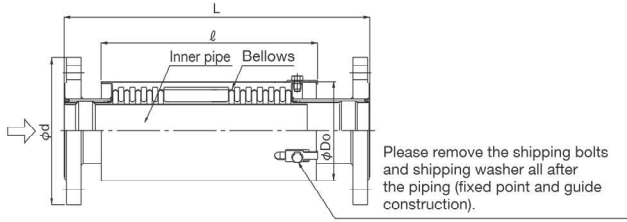

Nominal size	L	Max. operating length	Min. operating length	Max. axial extension	Do	d	ℓ	Weight
20A	365	375	340	35	58.2	100	235	2.7
25A	365	375	340	35	58.2	125	235	3.6
32A	365	375	340	35	73.2	135	235	4.4
40A	365	375	340	35	73.2	140	235	5.3
50A	365	375	340	35	98.2	155	239	6.8
65A	415	425	390	35	109.7	175	289	9.5
80A	415	425	390	35	135.7	200	288	13.1
100A	415	425	390	35	161.7	225	288	13.9
125A	440	450	415	35	212.1	270	292	34.7
150A	440	450	415	35	235.1	305	293	43.2
200A	440	450	415	35	291.6	350	280	55.8
250A	465	475	440	35	332.6	430	287	85.7

· Available with nominal size from 300A to 450A (EB-7).

· EB-12

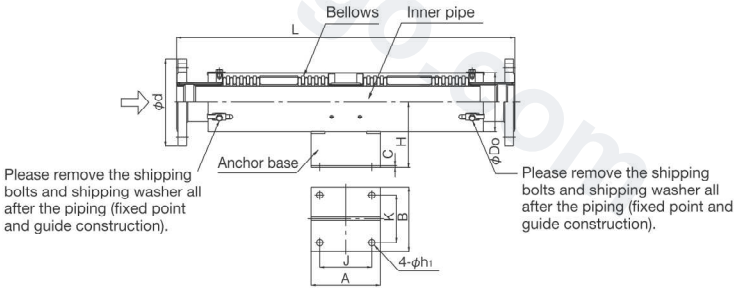

Nominal size	L	Max. operating length	Min. operating length	Max. axial extension δ	Do	d	Dimensions of anchor base-JIS B 2352							Weight	
							H	J	K	A	B	C	h ₁		Bolt size
20A	680	700	630	70	58.2	100	100	100	60	135	95	3.2	12	M10	4.8
25A	680	700	630	70	58.2	125	100	100	60	135	95	3.2	12	M10	5.7
32A	680	700	630	70	73.2	135	120	100	70	135	105	3.2	12	M10	7.5
40A	680	700	630	70	73.2	140	120	100	70	135	105	3.2	12	M10	7.6
50A	680	700	630	70	98.2	155	130	100	80	140	120	3.2	15	M12	10.8
65A	780	800	730	70	109.7	175	140	120	100	160	140	4.0	15	M12	13.4
80A	780	800	730	70	135.7	200	150	120	110	160	150	4.0	15	M12	18.2
100A	880	900	830	70	161.7	225	170	120	130	160	175	4.0	19	M16	21.6
125A	880	900	830	70	212.1	270	200	120	150	175	205	4.0	19	M16	48.2
150A	930	950	880	70	235.1	305	220	160	180	215	235	4.5	23	M20	58.5
200A	930	950	880	70	291.6	350	250	160	220	215	285	4.5	25	M22	80.4
250A	980	1000	930	70	332.6	430	300	180	280	255	375	4.5	27	M24	116.2

· Available with nominal size from 300A to 450A (EB-8).