

GD-26GS, 27GS

Direct type	Pilot type	Piston	Diaphragm
Bellows	Internal sensing	External sensing	Stainless steel
With handle	Built-in strainer	Low pressure	Remote
Valve leakage 0	Nylon		



GD-26GS



GD-27GS

■Features

1. Stainless steel is used for wetted parts.
2. Reduced noise.
3. Pressure balance structure can keep the reduced pressure at a constant level without being affected by inlet pressure.
4. Maintenance and inspection can be conducted easily by disassembling simply from the upper side.
5. Compact and lightweight, easy to handle on piping.

■Specifications

Model	GD-26GS	GD-27GS
Application	Air, Other non-dangerous fluids *	
Inlet pressure	1.0 MPa or less	
Reduced pressure	(A) 0.05-0.35 MPa (B) 0.3-0.7 MPa	
Application temperature	5-90°C	
Minimum differential pressure	0.05 MPa	
Maximum pressure reduction ratio	10:1	
Material	Body	Cast stainless steel
	Valve seat	Cast stainless steel
	Valve disc	EPDM
	Diaphragm	EPDM
Connection	JIS Rc screwed	JIS 10K FF flanged

* Please contact us when using for gas containing oil

- A strainer (40 mesh) is incorporated in 15A to 50A.
- 65A to 100A do not include strainer.
- Pressure gauge connection port is JIS Rc 1/4.
(Select from ϕ 42-MAX 1.0 MPa, 0.4 MPa, and 0.2 MPa).
- Available with FKM.



■ Dimensions (mm) and Weights (kg)

· GD-26GS

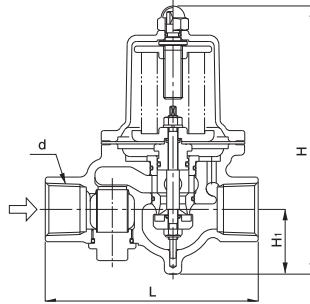

Nominal size	d	L	H	H ₁	Weight
20A	Rc 3/4	135	170	41	2.2
25A	Rc 1	135	170	41	2.2
32A	Rc 1-1/4	180	224	57	4.7
40A	Rc 1-1/2	180	224	57	4.5
50A	Rc 2	200	239.5	61	6.5

· GD-27GS

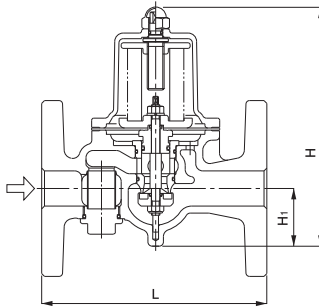

25A-50A

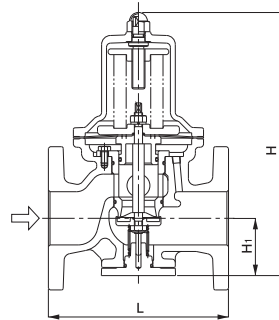

65A-100A

Nominal size	L	H	H ₁	Weight
20A	160	170	41	3.9
25A	160	170	41	4.8
32A	200	224	57	8.0
40A	200	224	57	8.3
50A	220	239.5	61	10.8
65A	220	329	77	20.6
80A	230	345	82	22.0
100A	270	412	94	34.5

Pressure Characteristic Chart

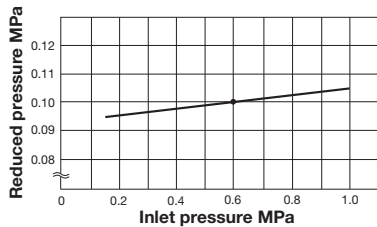

This chart shows variation in reduced pressure when the inlet pressure of 0.6 MPa is changed between 0.15 MPa and 1.0 MPa while the reduced pressure is set at 0.1 MPa.

Flow Characteristic Chart

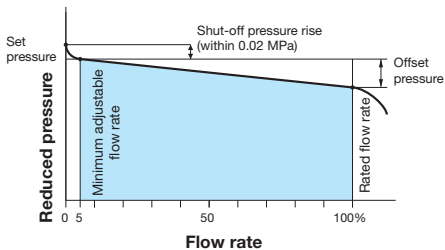

Nominal size	Pressure range	Offset pressure
15-100A	(A) 0.05-0.35 MPa	Within 0.05 MPa
	(B) 0.3-0.7 MPa	Within 0.10 MPa

Nominal Sizes Selection Chart

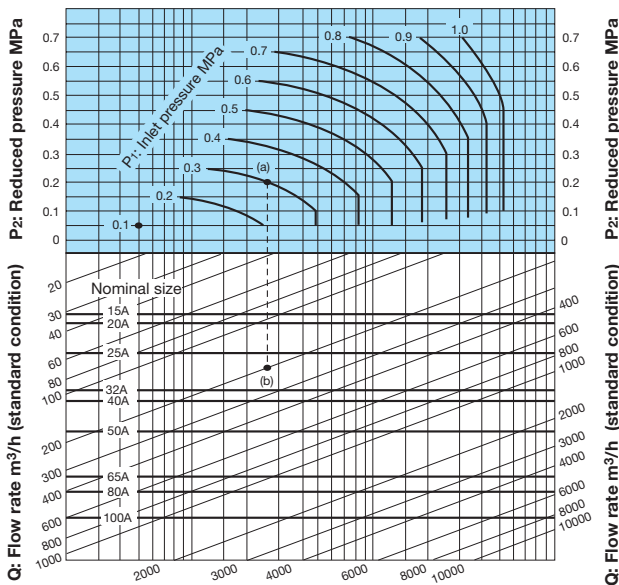

[Example]

When selecting the nominal size of a pressure reducing valve whose inlet pressure (P_1), reduced pressure (P_2), and flow rate are 0.3 MPa, 0.2 MPa, and 200 m^3/h (standard condition), respectively, first find intersection point (a) of the inlet pressure (P_1) of 0.3 MPa and the reduced pressure (P_2) of 0.2 MPa. Trace down vertically from this intersection point to find intersection point (b) with the flow rate of 200 m^3/h (standard condition). Since intersection point (b) lies between nominal sizes 25A and 32A, select the larger one, 32A.

* Set the safety factor at 80 to 90%.