

# Model GD-45·45P PRESSURE REDUCING VALVE

## Installation & Operation Manual

Please read this bulletin thoroughly before using the pressure reducing valve, so that you may do so correctly and safely. Please carefully store this bulletin in a handy place.

-----The following safety symbols are used in this manual.-----

 **Warning**

This symbol indicates a potentially hazardous situation that, if not avoided, could result in death or serious injury.

 **Caution**

This symbol indicates a hazardous situation that, if not avoided, may result in minor or moderate injury. ("Caution" may also be used to indicate other unsafe practices or risks of property damage.)

### Contents

1. Specifications .....	1
2. Dimensions and Weights .....	2
3. Operation .....	3
4. Nominal Size Selection Chart.....	4
5. Installation	
5.1 Example of piping .....	5
5.2 Precautions during installation .....	5
6. Operating Procedure	
6.1 Precautions during operation.....	6
6.2 Adjustment procedures .....	7
7. Maintenance Procedure	
7.1 Troubleshooting.....	7
7.2 Precautions during maintenance and inspection .....	8
7.3 Disassembly procedure.....	8
7.4 Precautions during disassembly.....	9
7.5 Exploded drawing .....	9
After Sale Service	

# YOSHITAKE

## 1. Specifications

Model	GD-45		GD-45P
Size	15,20,25A		
Fluid	Steam		
Connection	JIS Rc Screwed		
Inlet Pressure	2.0MPa or less		
Reduced Pressure	Type	Spring Color	Setting Pressure range
	A Spring	Yellow	0.02~0.1MPa
	B Spring	Blue	0.05~0.4 MPa
	C Spring	Yellow-green	0.35~1.0 MPa
Minimum differential Pressure	0.05 MPa		
Max. pressure reducing ratio	10:1		
Max. Temperature	220°C		
Valve Seat Leakage	Rated leakage is 0.1% or less of rated flow		
Material	Body	Ductile Cast Iron	
	Cap	Ductile Cast Iron	
	Bellows	Bronze	
	Spring Chamber	Cast Iron	
	Valve seat	Stainless Steel	
	Valve	Stainless Steel	
	Handle	—	Polyphenylene sulfide
Body hydraulic test	4.0 MPa		

### Caution

Please collate with attached nameplate and specification of ordered model.  
Please consult factory in case they do not match each other.

## 2. Dimensions and Weights

### ■ GD-45

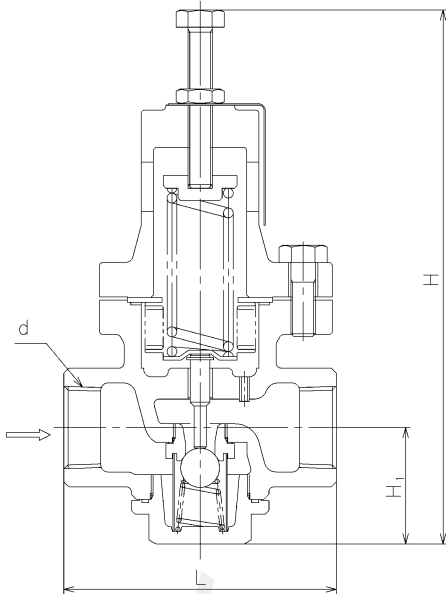

Size	d	L (mm)	H1 (mm)	H (mm)	Weight (kg)
15A	JIS Rc 1/2	111	47	216	3.2
20A	JIS Rc 3/4	111	47	216	3.2
25A	JIS Rc 1	111	47	216	3.2

### ■ GD-45P

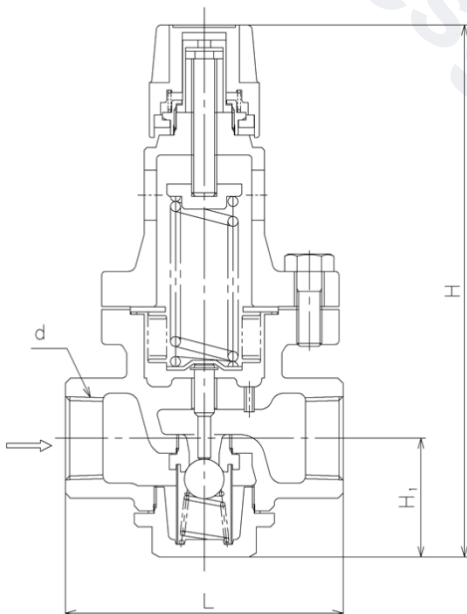

Size	d	L (mm)	H1 (mm)	H (mm)	Weight (kg)
15A	JIS Rc 1/2	111	47	213	3.2
20A	JIS Rc 3/4	111	47	213	3.2
25A	JIS Rc 1	111	47	213	3.2

### 3. Operation

When the adjusting screw clockwise compresses the spring, the bellows are extended and the spindle opens the valve. When the valve opens, the steam flowing to the outlet side passes through the reduced pressure detection hole, and becomes an upwardly directed pressure under the bellows and balances the force of the spring. The degree of valve opening is adjusted by the balancing of inlet and reduced pressures, there by stabilizing reduced pressure.

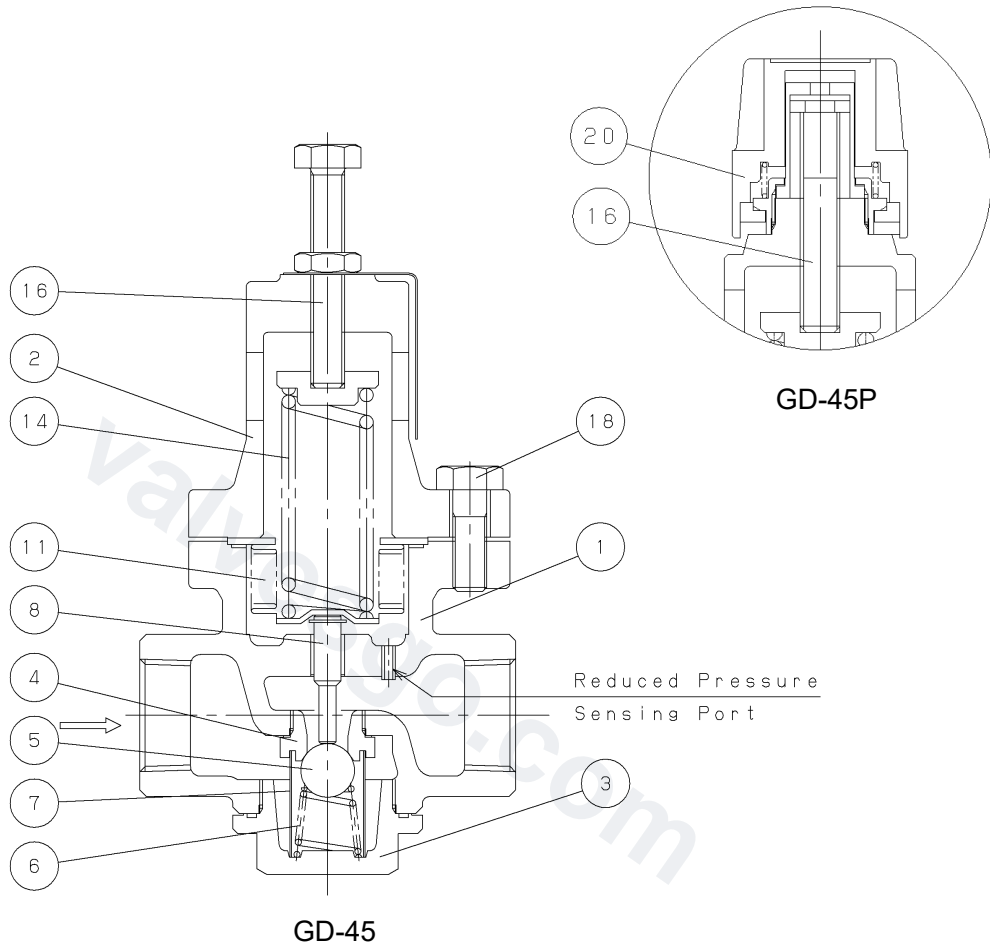

No.	Parts Name	No.	Parts Name
1	Body	8	Spindle
2	Spring Chamber	11	Bellows
3	Cap	14	Adjusting Spring
4	Valve Seat	16	Adjusting Screw
5	Valve	18	Bolts
6	Valve Spring	20	Handle (Only GD-45P)
7	Screen		

#### 4. Nominal Size Selection Chart

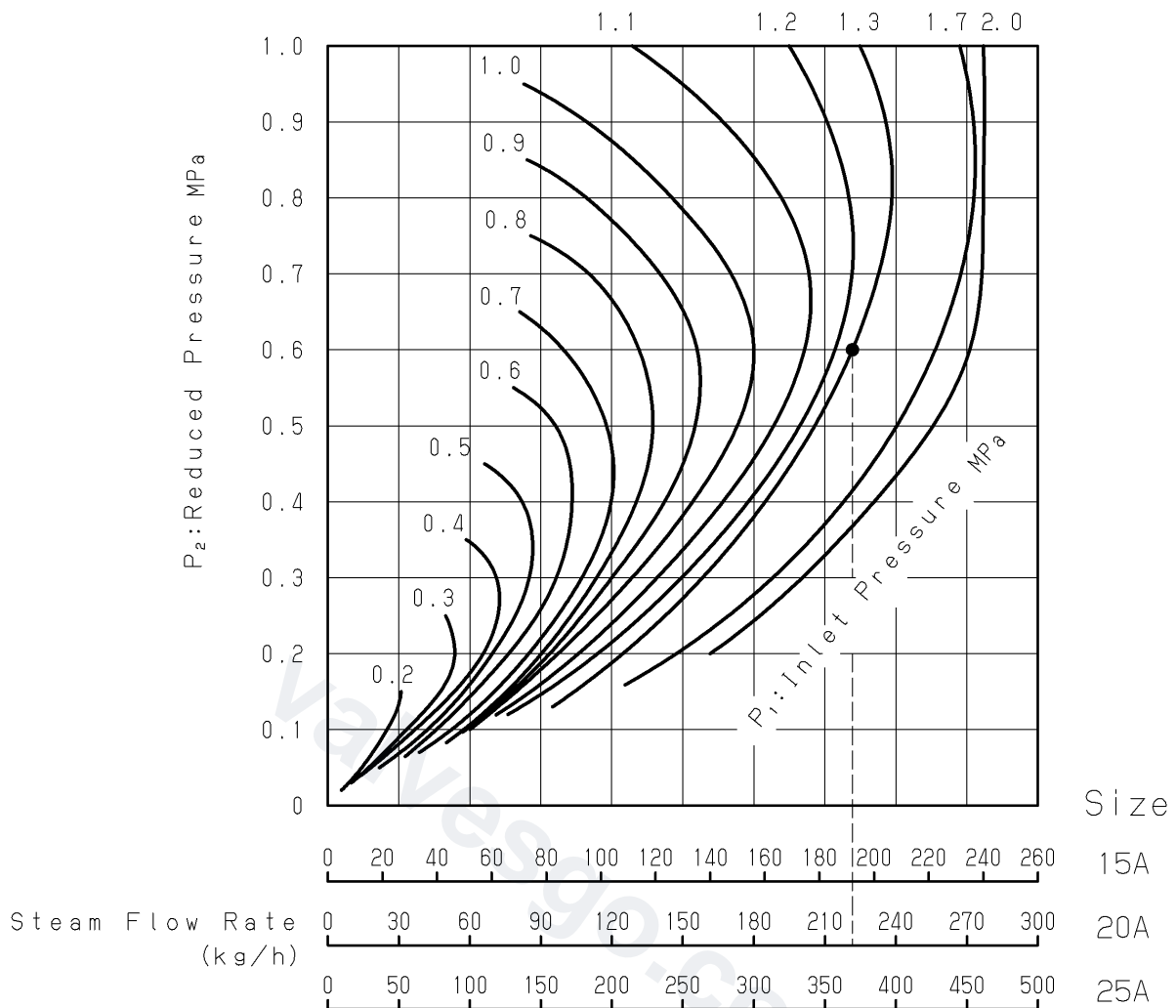

#### [Example]

Under the following operating conditions, the appropriate nominal size would be determined as described below.

Inlet pressure ( $P_1$ ): 1.3 MPa

Reduced pressure ( $P_2$ ): 0.6 MPa

Steam flow rate: 200 kg/h

First, find the point where the inlet and reduced pressures intersect. Next draw a line straight down from that point to the nominal size scale where a flow rate of 200 kg/h or more is indicated. The appropriate nominal size is indicated at the right side of the flow rate scale. For the above example, a nominal size of 20A should be selected.

## 5. Installation

### 5.1 Example of piping

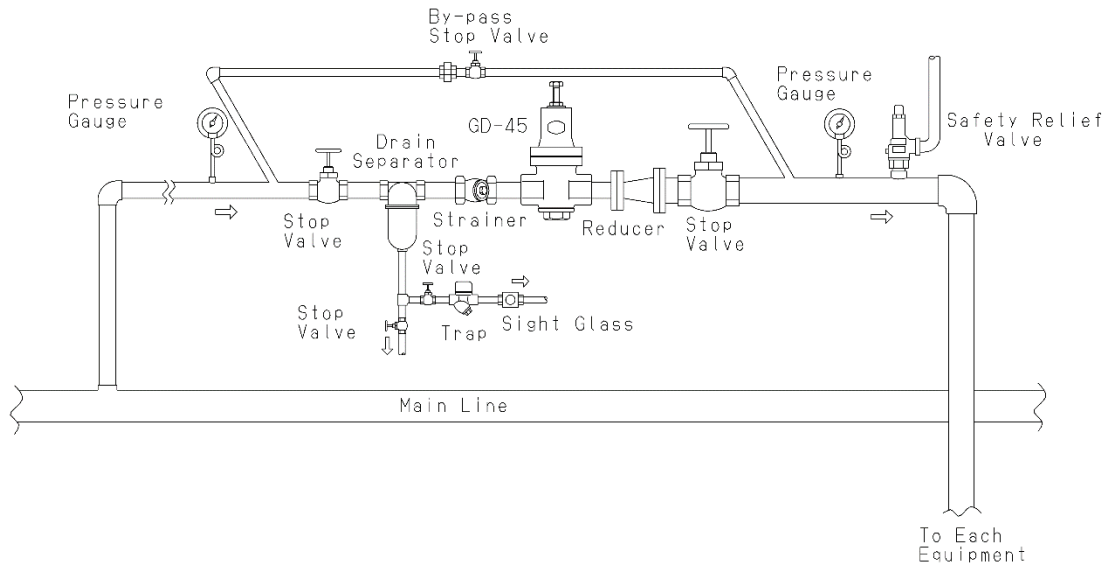

### 5.2 Precautions during installation

#### Warning

In case installing safety valve as safety device at outlet side, joint relief pipe at outlet of safety valve and guide it to safety place where steam can relief out.

※Failure to do so may result in burns.

#### Caution

- (1) Do not disassemble the valve unreasonably.  
※Disassembling the valve at your discretion may affect the original performance.
- (2) Remove foreign matter and scales from the lines before connecting the valve.  
※Failure to do so may result in the valve from functioning incorrectly.
- (3) Install a strainer (80 mesh) at the valve inlet side.  
※Failure to do so may hamper correct pressure control, which affects the original performance.
- (4) Install a safety valve at the valve outlet sides as safety device for equipment.  
※Failure to do so cannot identify PRV problem, resulting in equipment damage.
- (5) Install a pressure gauge at both the inlet and outlet sides of the valve.  
※Failure to do so may hamper correct pressure adjustment.
- (6) Install a steam trap to the inlet sides of the valve to prevent drainage problems.  
※Failure to do so may result in drainage problem, affecting the original performance.
- (7) When installing quick open and close valves, such as a solenoid valve, install it at inlet side as much as possible, and secure at least 3 m from the valve.  
※Failure to do so may result in malfunction or drastically shortened service life.
- (8) When pressure reducing in two stages, secure at least 3 m between the valves.  
※Failure to do so may result in malfunction, affecting the original performance.
- (9) Install the valve in proper direction of the fluid flow.  
※Failure to do so may affect the original performance.
- (10) Do not apply excessive load, torque or vibration to the valve.  
※Doing so may result in malfunction or drastically shortened service life.
- (11) Install the valve perpendicularly to horizontal lines.
- (12) Provide the by-pass line. (See 5.1 Example of piping)
- (13) Set pressure of safety relief valve should be higher than the pressure reducing valve's pressure.
- (14) When the reducing ratio is large, install a reducer to keep the flow velocity in the pipe 30 m/s.

- (15) Provide space on the top and bottom of the valve so that the valve can be easily disassembled and inspected. (See Fig.1)

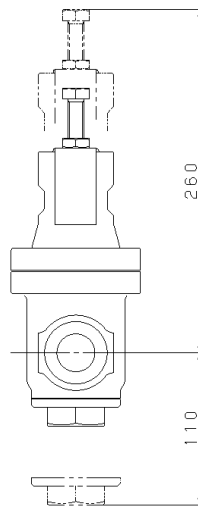

Fig.1

## 6. Operating Procedure

### 6.1 Precautions during operation

#### ⚠ Warning

- (1) Do not touch the valve directly with bare hands.  
※Doing so may result in burns.
- (2) Do not touch the handle directly with bare hands. Use protective leather gloves while operating the valve. (GD-45P)  
※Doing so may result in injury or burns.
- (3) Before flow the steam in pipeline, make sure steam can flow without any dangerous at the end of pipeline and pipeline is connected tightly.  
※In case steam blow off, it may result in burns.

#### ⚠ Caution

- (1) Close the stop valves before and after the reducing valve, and remove all foreign matter and scales via the by-pass line before operation. And, open each stop valve slowly.  
※Failure to do so may prevent the valve from functioning correctly. And, It may cause hunting, water hammer, etc., resulting in damage to the valve and other equipment when the stop valve is opened quickly.
- (2) Secondary pressure at by-pass line must be lower than set pressure.  
※ Safety valve blows in case secondary pressure at by-pass line becomes higher than set pressure.
- (3) When adjusting pressure, slowly turn the handle. Incorrect adjustment may cause hunting, water hammer, etc., it may result in damage to the valve and other equipment.
- (4) Do not use tools to turn the handle. (GD-45P)  
※Doing so may result in damage to the handle.
- (5) Press and turn the handle. (GD-45P)  
※The handle usually does not rotate due to the stopper. Do not force it to turn or it may get damaged.
- (6) The rotation range of the handle is limited. Do not rotate it over the limit. (GD-45P)  
※Doing so may result in damage to the handle.

## 6.2 Adjustment Procedure

Follow the steps below, and slowly turn the adjusting screw to set pressure. Incorrect adjustment may cause hunting, water hammer, etc., resulting in damage to the valve and other equipment.

### ■ Adjusting procedure for GD-45

- (1) Close the stop valve at inlet and outlet side of the pressure reducing valve, and taking sufficient time not to blow the safety valve, blow off the fluid to remove foreign matter via the by-pass line. After blowing, close the by-pass line stop valve.
- (2) Slowly open the stop valve at the inlet side of the pressure reducing valve, and adjust the travel of the stop valve at the outlet side of the pressure reducing valve so that a little fluid flows.
- (3) Loosen the lock nut, and slowly turn the adjusting screw to achieve the desired pressure (clockwise to increase, counterclockwise to reduce) while observing the pressure gauge on the outlet side.
- (4) Slowly open the stop valve at the outlet of the pressure reducing valve, and readjust the desired pressure. After adjustment, tighten the lock nut.

### ■ Adjusting procedure for GD-45P

- (1)(2) Same as GD-45.
- (3) Press and slowly turn the handle until the pressure is adjusted to the desired level checking the pressure gauge mounted on the outlet side. Turn the handle clockwise to increase, and counterclockwise to decrease the pressure.
- (4) Slowly open the stop valve at the outlet side, and make fine adjustments to the reduced pressure.

## 7. Maintenance Procedure

### 7.1 Troubleshooting

Problem	Cause	Solution
Pressure does not rise to the desired level.	<ol style="list-style-type: none"> <li>1. Incorrect pressure is being used.</li> <li>2. Nominal size is too small for these specifications.</li> <li>3. Incorrect adjustment.</li> <li>4. Strainer installed before pressure reducing valve is clogged.</li> <li>5. Screen is clogged.</li> <li>6. Pressure gauge malfunction.</li> </ol>	<ol style="list-style-type: none"> <li>1. Correct the pressure.</li> <li>2. Replace with the correct nominal sized item.</li> <li>3. Re-adjust according to the adjustment procedure.</li> <li>4. Disassemble and clean.</li> <li>5. Disassemble and clean.</li> <li>6. Replace the pressure gauge.</li> </ol>
Reduced pressure exceeds prescribed level.	<ol style="list-style-type: none"> <li>1. Foreign matter is embedded in the valve and/or valve seat, or else scratches exist.</li> <li>2. Reduced pressure sensing hole is clogged with foreign matter.</li> <li>3. By-pass valve is leaking.</li> </ol>	<ol style="list-style-type: none"> <li>1. Disassemble and clean. If scratches exist, polish them away.</li> <li>2. Disassemble and clean.</li> <li>3. Repair or replace the valve.</li> </ol>
Abnormal noise is heard.	<ol style="list-style-type: none"> <li>1. Pressure reduction ratio is too large.</li> <li>2. Drainage problem.</li> <li>3. An abrupt open/close valve is located too close to the pressure reducing valve.</li> </ol>	<ol style="list-style-type: none"> <li>1. Use a two-stage reduction.</li> <li>2. Install a trap.</li> <li>3. Move distance as much as possible between the valves.</li> </ol>

## 7.2 Precautions during maintenance and inspection

### Warning

Completely discharge internal pressure from the valves, lines, and equipment, and cool the valve down to a level where you can touch it with bare hands before disassembly and inspection.

※Failure to do so may result in injury or burns due to residual pressure or spillage around the valve.

### Caution

(1) In order to maintain original performance and function, examine daily and personal inspection. And, periodical inspection must be examined according to the regulations of every kind.

※For general users, request to specialized in dealer or manufacture.

(2) Pressure reducing valve shall be disassembled and inspected by qualified person or manufacture.

※Request the treatment to specialized dealer or manufacture in case of any problems.

(3) While disassembly, drain flow out from the valve, so catch it by container. And release steam completely before disassembling.

※In case of no container for drain, it makes dirty surrounding the valve.

(4) Close the stop valves before and after the reducing valve, and remove all foreign matter and scales via the by-pass line before operation.

※Failure to do so may result in the valve from functioning incorrectly.

## 7.3 Disassembly procedure

Be sure that the stop valves at inlet and outlet side of pressure reducing valve is closed and all internal pressure and condensate have discharged before disassembling the valve.

### ■ Disassembly procedure for GD-45

(1) Loosen the lock nut [17] and turn the adjusting screw [16] to release the adjusting spring [14] (no compression).

(2) Remove the bolt [18] of the spring chamber [2]. Remove the spring chamber, adjusting spring, the spring plate [15], the bellows [11], and the spindle [8].

(3) Loosen and remove the cap [3]. Then remove the valve spring [6], the screen [7] and the valve [5].

### ■ Disassembly procedure for GP-45P

(1) Press and slowly turn the handle [20] counterclockwise till it stops, and then release the adjusting spring [14] to the no-load condition.

(2) Remove the bolts [18], spring chamber [2] and handle first, and then remove the adjusting spring, spring plate [15], bellows [11] and spindle [8].

(3) Loosen and remove the cap [3] (Watch out for the drain discharged.), and then remove the valve spring [6], screen [7] and valve [5].

## 7.4 Precautions during disassembly

### Caution

- (1) Check that there is no damage and scratches on the valve [5], and the valve seat [4].  
 ※Any scratches at sealing surface lead to increase in secondary pressure. When any scratches are identified at valve and seat, polish them away. And, change the parts if scratches still exist after polishing.
- (2) Move the spindle two to three times and confirm they move smoothly.  
 ※If the sliding parts do not move correctly, it may cause failure problems. (Working not correctly).
- (3) Replace the gasket [13] [12] with new ones when reassembling.  
 ※If the gasket is used for a long time, it may cause steam leakage problem.
- (4) Assemble in the reverse order of Disassembly. And tighten the bolts evenly.  
 ※Assemble the valve due to the order. Failure to do so may lead to not assemble correctly. And if the hexagon bolts are not screwed correctly, it may cause steam leakage problem.
- (5) Check that screen is not clogged. When screen is clogged, disassemble and clean it.  
 ※Failure to do so may result in the valve from functioning incorrectly.

## 7.5 Exploded drawing

### ■ Exploded drawing of GD-45

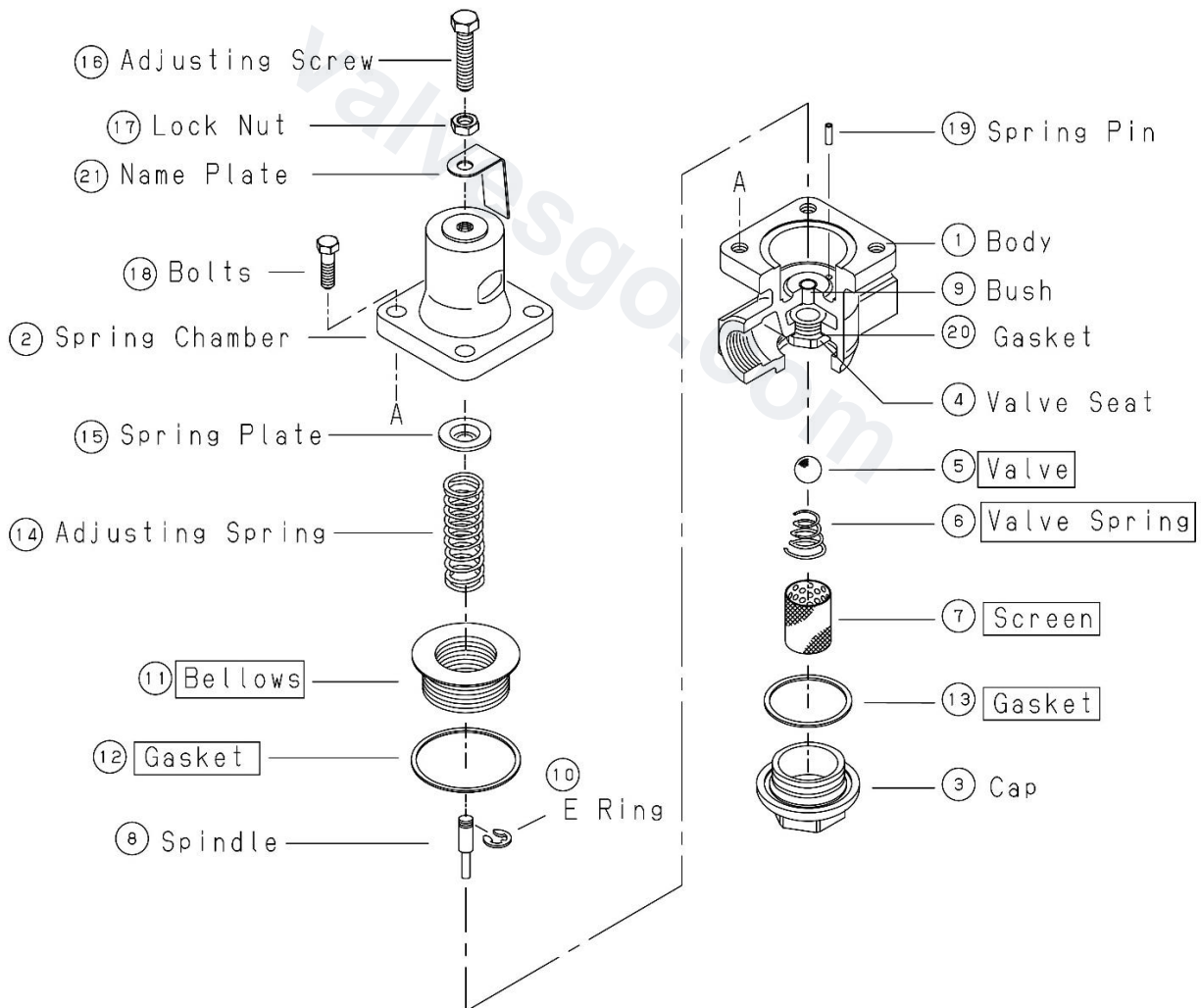

※Part names shown in boxes are consumable items.

■ Exploded drawing of GD-45P

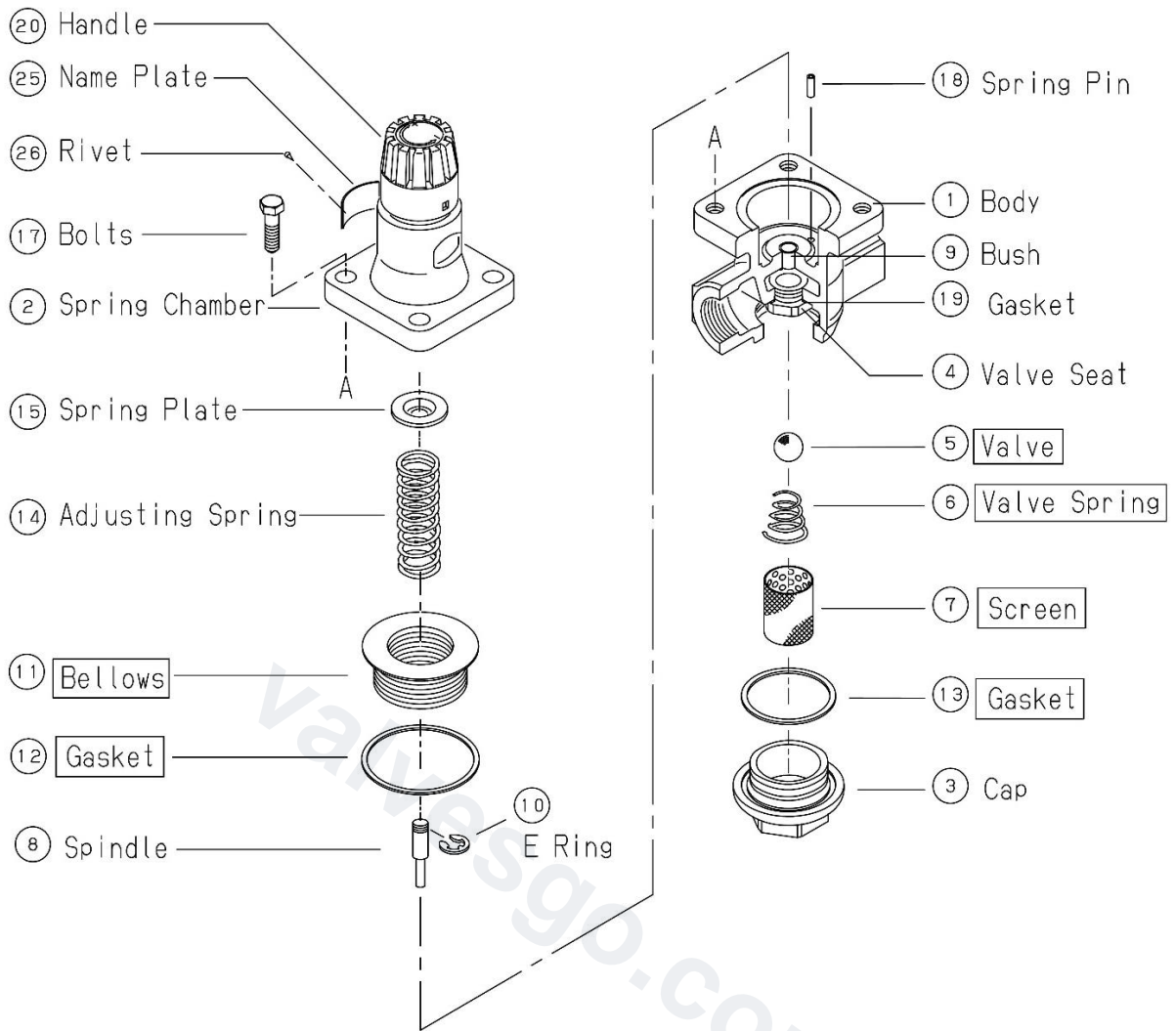

※Part names shown in boxes are consumable items.

---

## Warranty Information

---

1. Limited warranty

This product has been manufactured using highly-advanced techniques and subjected to strict quality control. Please be sure to use the product in accordance with instructions on the manual and the label attached to it.

Yoshitake warrants the product to be free from any defects in material and workmanship under normal usage for a period of one year from the date of receipt by the original user, but no longer than 24 months from the date of shipment from Yoshitake's factory.

2. Parts supply after product discontinuation

This product may be subject to discontinuation or change for improvement without any prior notice. After the discontinuation of the product, Yoshitake supplies the repair parts for 5 years otherwise individually agreed.

3. This warranty does not cover the damage due to any of below:

- (1) Valve seat leakage or malfunction caused by foreign substances inside piping.
- (2) Improper handling or misuse.
- (3) Improper supply conditions such as abnormal water pressure/quality.
- (4) Water scale or freezing.
- (5) Trouble with power/air supply.
- (6) Any alteration made by other than Yoshitake.
- (7) Use under severe conditions deviating from the design specifications (e.g. in case of corrosion due to outdoor use).
- (8) Fire, flood, earthquake, thunder and other natural disasters.
- (9) Consumable parts such as O-ring, gasket, diaphragm and etc.

Yoshitake is not liable for any damage or loss caused by malfunction or defect of the product.

**YOSHITAKE** 