

GD-46 Series



JWWA approval

The GD-46 Series water pressure reducing valve enables to shorten a construction work period since water pressure inspection can be performed easily by turning the cap upside down with the valve installed.



GD-46PP



GD-46D

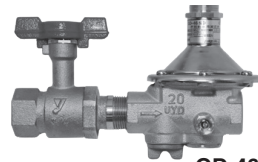

GD-46SD

■Features

1. Reduced noise. Can be used even late at night.
2. Water pressure inspection can be performed easily by turning the cap upside down with the valve installed.
3. Pressure balance structure can keep the reduced pressure at a constant level without being affected by inlet pressure.
4. Attached pressure gauge joint allows a pressure gauge to be installed while water is supplied so that the set pressure can be checked easily.
5. Noise characteristics and flow characteristics conform to the “Quality Criterion on Materials” of Urban Renaissance Agency in Japan.

■Specifications

Nominal size		20A
Application		City water
Inlet pressure		1.0 MPa or less
Reduced pressure		(A) 0.05-0.10 MPa (Standard setting: 0.09 MPa)
		(B) 0.10-0.22 MPa (Standard setting: 0.20 MPa)
		(C) 0.20-0.30 MPa (Standard setting: 0.25 MPa)
Minimum differential pressure		0.02 MPa
Maximum pressure reduction ratio		10:1
Working temperature	Without pipe end core	5-90°C
	Equipped with pipe end core	5-40°C
	Equipped with check valve	5-60°C
Minimum adjustable flow rate		0.5 L/min
Rated flow rate	Without check valve	50 L/min (Differential pressure before and after valve: 0.10 MPa or more)
	Equipped with check valve	30 L/min (Differential pressure before and after valve: 0.10 MPa or more)
Material	Body	Cast bronze (NPb-treated)
	Spindle	Dezincification resistant material
	Valve disc	Synthetic rubber/Stainless Steel
	Diaphragm	Synthetic rubber
Pressure check function		Pressure gauge joint (JIS Rc 1/8 screwed)
Outlet withstand pressure		1.2 times the maximum working pressure of outlet side

- Available with pressure gauge (type A or type D) as an optional extra (for 0.5 MPa).
- The accuracy of a pressure gauge is $\pm 3\%$ F.S.
- The strainer is 60 mesh.
- The product is set to the pressure reducing valve function when it is delivered from the factory.
- An incombustible material is used for heat insulating material.
- Stop valve is not made with dezincification resistant material.

■ Dimensions of the Heat Insulating Material

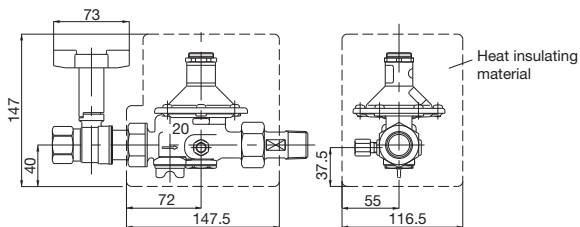

GD-46SP

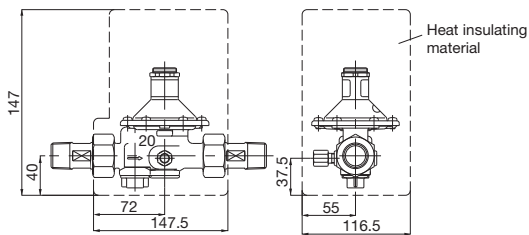

GD-46PP

Note) The heat insulating material is common to all GD-46 Series valves.
However, no heat insulating material is used for the water stop valve.

■ Dimensions of the Valve Equipped with the Optional Pressure Gauge

· Equipped with the pressure gauge Type A

· Equipped with the pressure gauge Type D

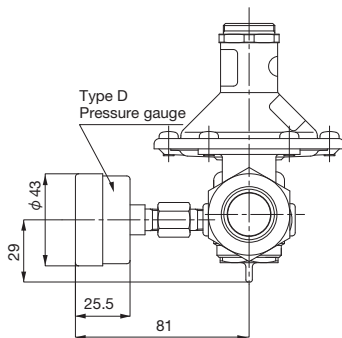
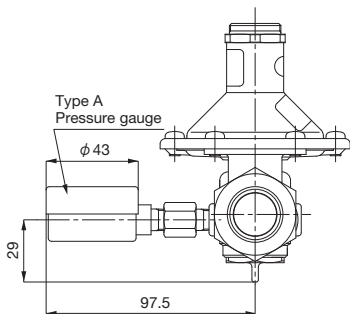

Flow Characteristic Chart

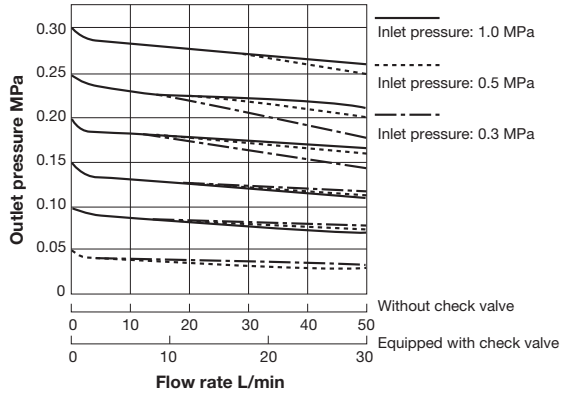

Noise Characteristic Chart

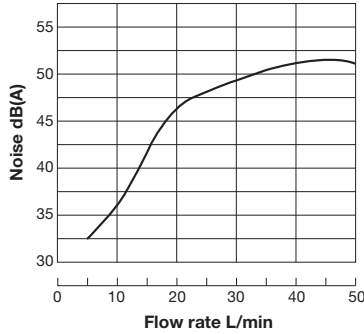

<Test conditions>

- Inlet pressure: 0.6 MPa
- Reduced pressure: 0.2 MPa
- Distance from the sample valve to the microphone: 15 cm
- Background noise: 30 dB (A)
- (Except for the valve equipped with a check valve)

Pressure Characteristic Chart

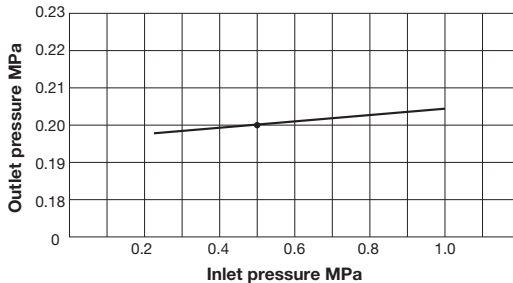

This chart shows variation in reduced pressure when the inlet pressure of 0.5 MPa is changed between 0.22 MPa and 1.0 MPa while the reduced pressure is set at 0.2 MPa.

■ How to Adjust the Pressure

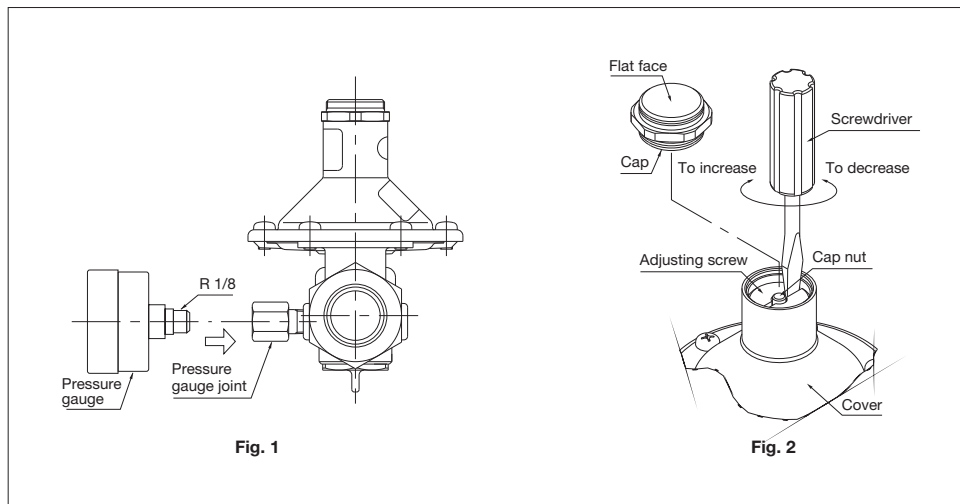

Fig. 1

Fig. 2

1. Screw the pressure gauge into the pressure gauge joint (Fig. 1).
2. Remove the cap. By checking the pressure gauge, turn the adjusting screw to adjust the reduce pressure to a desired level. (Fig.2).
 - The reduced pressure increases when the adjusting screw is turned clockwise.
 - The reduced pressure decreases when the adjusting screw is turned counterclockwise.

Note) Use a keystone tip screwdriver of 4.5 to 6 mm in nominal width for slotted head screws. Set the screwdriver in the slot of the adjusting screw avoiding the cap nut attached in the center of the screw, and adjust the reduced pressure. If pressure adjustment is difficult to make, please contact us.
3. After reduced pressure adjustment, attach the cap with the flat face up.
4. Remove the pressure gauge.

Problem	Possible cause	Corrective action
Low flow rate.	· Strainer is clogged.	Clean the strainer.
	· Setting pressure is low.	Adjust the pressure by following the adjusting steps.
Secondary pressure is higher than the set pressure.	· The cap is left in water pressure test status.	Flat surface part of cap should be upside.
External leakage.	· Set screw, valve cap, strainer cap is loose.	Retighten the round head screw, valve cap, and the strainer cap.
	· O ring or gasket is damaged.	Replace the O ring and gasket with a new one.
	· Joint of pressure gauge is loosen.	Remove the joint. Apply seal tape to the thread and attach the joint to the valve body.

■Dimensions (mm) and Weights (kg)

Model	Connection	L	Weight
	Inlet x outlet		
GD-46	G 1 x G 1	-	1.0
GD-46PP-46PPC	R 3/4 x R 3/4	218	1.4
GD-46KK-46KKC-46LL-46LLC	Rc 3/4 x Rc 3/4	214	1.5
GD-46PK-46PKC-46PL-46PLC	R 3/4 x Rc 3/4	216	1.4
GD-46KP-46KPC-46LP-46LPC	Rc 3/4 x R 3/4	216	1.4
GD-46PG	R 3/4 x G 1-3/4	165	1.2
GD-46GP-46GPC	G 1 x R 3/4	165	1.2
GD-46KG-46LG	Rc 3/4 x G 1	163	1.2
GD-46GK-46GKC-46GL-46GLC	G 1 x Rc 3/4	163	1.2
GD-46SG	Rc 3/4 x G 1	194.5	1.4
GD-46SP-46SPC	Rc 3/4 x R 3/4	247.5	1.6
GD-46SL-46SLC-46SK-46SKC	Rc 3/4 x Rc 3/4	245.5	1.6

(GD-46 Series)

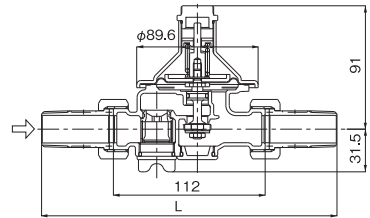

(Equipped with stop valve)

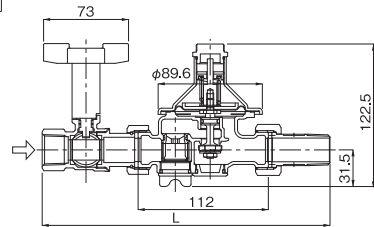

■ Joints and Water Stop Valves Used for GD-46 Series Valves

· Standard type

JO-36UP
JO-36UV

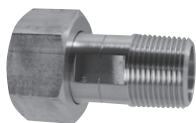

· Dimensions and weights

JO-36UV: $\phi D = 18.6$
JO-36UP: $\phi D = 20.4$

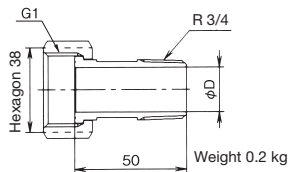

JO-36UL
JO-36UK

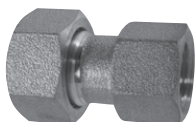

JO-36UK-JO-36UL

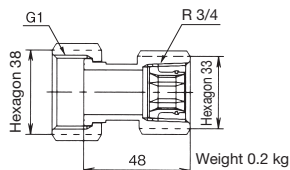

* JO-36UK is not provided with built-in pipe end core.

· Check valve incorporated type

CV-36UP
CV-36UV

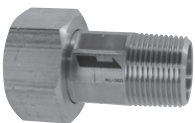

CV-36UV: $\phi D = 18.6$
CV-36UP: $\phi D = 20.4$

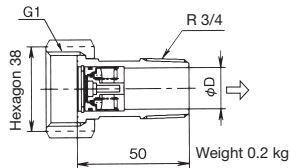

CV-36UL
CV-36UK

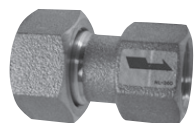

CV-36UKCV-36UL

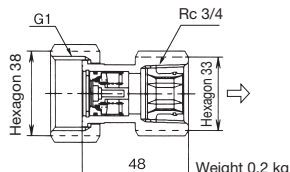

* CV-36UK is not provided with built-in pipe end core.

· Water stop valve

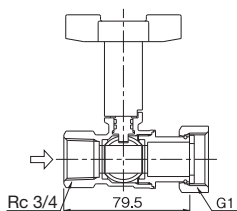

· Available with pipe end core.
Stop valve body is not made with dezincification resistant material.

About the Model for Individual Water Supply PRV

There are many variations of connections. Please select the suited model for design and construction from the following pictures and list.

How to see the model of GD-46 series

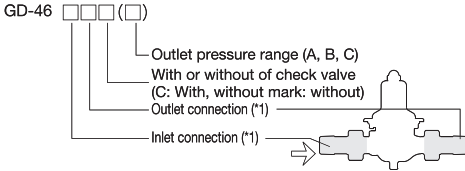

(*1) Symbol list

P	Common core or male thread prepared for P-shaped core
V	Common core or male thread prepared for V-shaped core
L	Female thread are prepared common core built in
K	Female thread of without tube end core (Built in available)
G	Parallel pipe male thread (G1)
S	Female for water stop valve (Inlet side)
D	Screwed (R 3/4)

Variation	Model for GD-46 series
1	GD-46PP · 46PPC
2	GD-46KK · 46KKC · 46LL · 46LLC
3	GD-46PK · 46PKC · 46PL · 46PLC
4	GD-46KP · 46KPC · 46LP · 46LPC
5	GD-46PG
6	GD-46LG · 46LG

Variation	Model for GD-46 series
7	GD-46GP · 46GPC
8	GD-46GK · 46GKC · 46GL · 46GLC
9	GD-46
10	GD-46SG
11	GD-46SP · 46SPC
12	GD-46SK · 46SKC · 46SL · 46SLC
13	GD-46D
14	GD-46SD

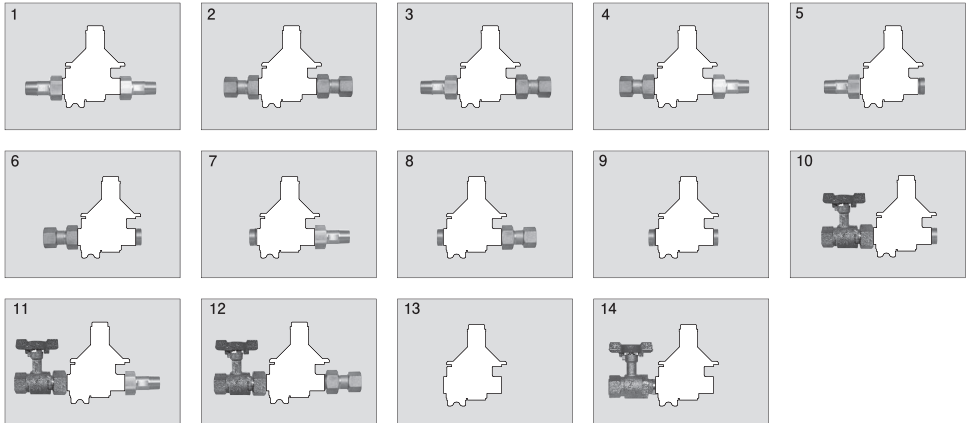

The inside of collective housing shaft

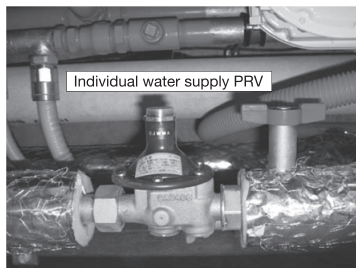
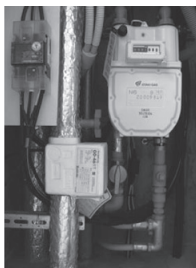

Piping of Individual Water Supply PRV

The typical piping examples of individual water supply PRV are shown below. When installing the product to the piping actually, please install it according to the installation manual for each products.

Notes on installation

1. Arrow mark on the body must match with flow direction when installing.
 2. Parallel Installation or vertical installation to the piping is available.
 3. Install after eliminating the dusts, scale, and sands from the piping.
 4. Do not touch the adjusting screw unnecessarily because setting pressure is adjusted to standard setting pressure.
 5. Clean one or two times more per year regularly because if the dust, scale and sands are stuck in the strainer, water would not come out smoothly.
 6. Foreign substance accumulates especially in the first plumbing, so check the strainer soon after starting water supply.
 7. Caution on piping installation of a vinyl chloride tubing. If the adhesive agent for the vinyl chloride tubing flows in the product, synthetic rubber may be involved in, so please be careful when installing.
 8. Use the polystyrene foam as insulation material. The band of insulation material is operation manual.
- Be sure to attach it on the body after installation so that you can see it any time.

Piping example

<Horizontal piping>

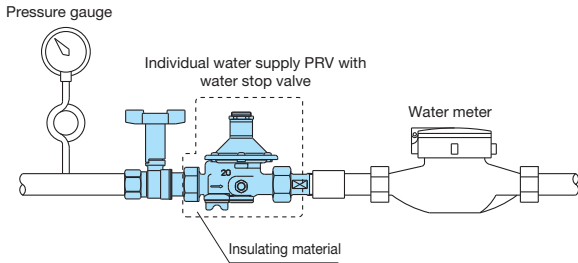

<Vertical piping>

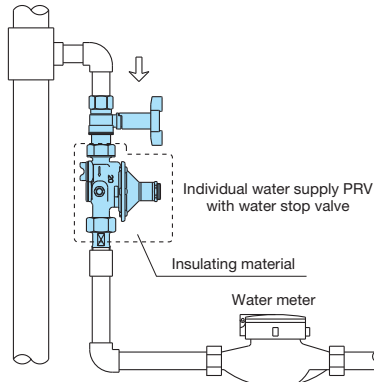



<Water tank system>

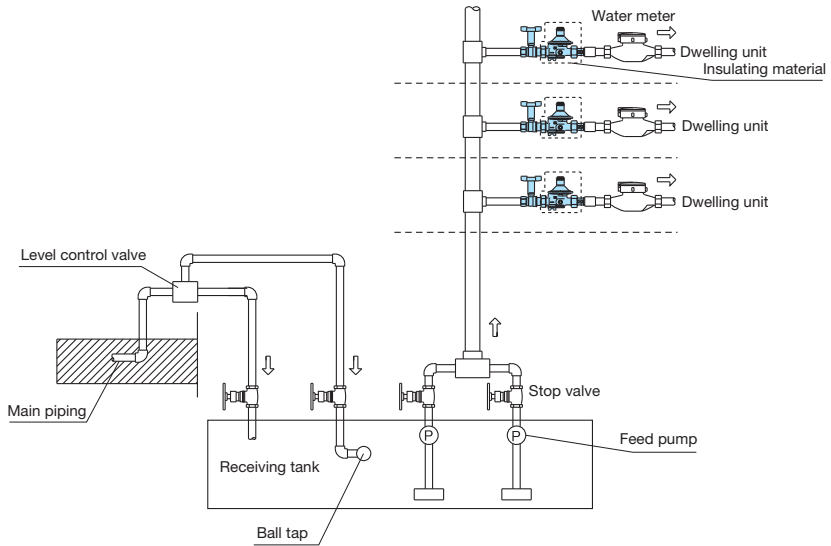

<Direct pressure system>

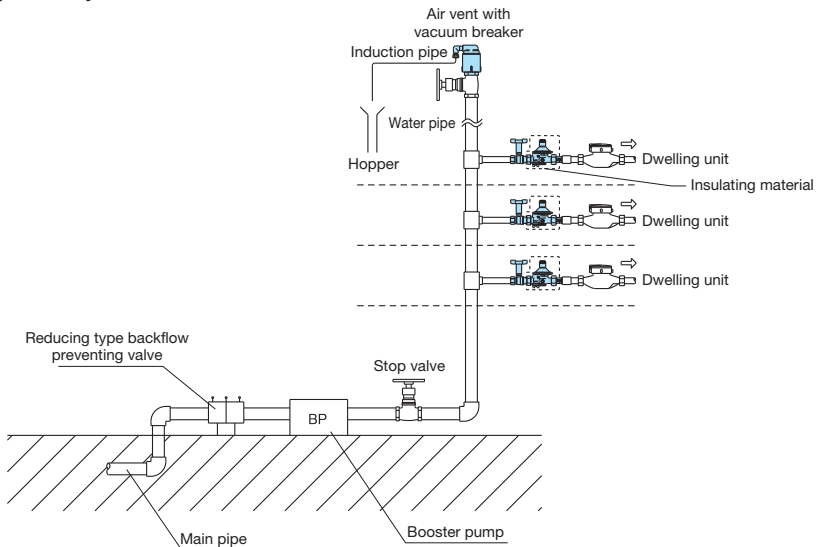

Water Pressure Inspection Procedure



Water pressure inspection procedure

[Switching procedure of GD-46 PRV]

1. Be sure to check that there is no internal pressure in the piping before water pressure inspection. If internal pressure remains inside, remove it.
2. Remove the cap and turn it out (make concave portion upward), and screw it firmly onto the spring cover. (Fig. 1)
 - * Do not screw the cap when there is internal pressure.
3. On water pressure inspection, be sure to check the concave portion of the cap is screwed in upward direction, and conduct the water pressure inspection at 1.75 MPa or less.
4. Take the internal pressure, and be sure to return the cap to the original position (making planar position upward) after water pressure inspection. (Fig. 2)
 - * If the cap does not return to its original position, the product cannot functions as a pressure reducing valve.

Bypass function

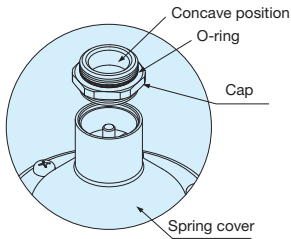

Fig. 1

Pressure reduction function

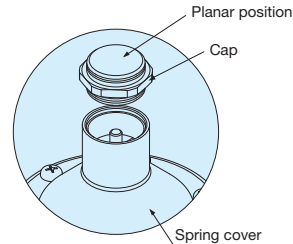

Fig. 2