

# GD-46 Series

## Home Water Pressure Reducing Valve

### Instruction Manual

#### Handling Precautions

Thank you for purchasing GD-46 series product. To correctly and safely use your GD-46, read through the document attached to the product and keep it for later reference.

— — — — Informational items that require to take proper safety operating procedure are given as WARNING or CAUTION: — — — —

 WARNING

This symbol indicates a potentially hazardous situation that, if not avoided, could result in death or serious injury.

 CAUTION

This symbol indicates a hazardous situation that, if not avoided, may result in minor or moderate injury. (“Caution” may also be used to indicate other unsafe practices or risks of property damage.)

#### Contents

1 .	Applications.....	1
2 .	Model	
2.1	Composition of model name.....	1
2.2	Model list .....	1
3 .	Specifications.....	2
4 .	Dimensions	
4.1	Dimensions and weights .....	3
4.2	Dimensions of heat insulating material .....	4
4.3	Dimensions with pressure gauge (option) .....	4
5 .	Flow characteristic curve .....	5
6 .	Noise characteristic curve ( w/o check valve).....	5
7 .	Pressure characteristic curve .....	6
8 .	Operational description .....	6
9 .	Installation	
9.1	Piping example .....	7
9.2	Precautions for installation.....	8 ~ 9
9.3	Precaution and procedure for water pressure inspection .....	1 0
10.	Operation	
10.1	Precaution for operation .....	1 1
10.2	Precaution and procedure for pressure adjustment.....	1 1
11.	Maintenance	
11.1	Troubleshooting guide .....	1 2
11.2	Precaution for maintenance and inspection .....	1 2
11.3	Disassembling.....	1 3
11.4	Troubleshooting.....	1 3
11.5	Precaution for assembly.....	1 3
11.6	Precaution for cleaning and how to clean.....	1 4
12.	Exploded drawing.....	1 5
	Part table .....	1 6
13.	Packing	
13.1	Packing figure .....	1 7
13.2	Contents of packing .....	1 7
After Sale Service		

# YOSHITAKE

1 . Applications

The model GD-46 home water supply reducing valve is installed on the water supply line to each household of, e.g., a complex housing to ensure that water is supplied at a regulated pressure.

2 . Model

2 . 1 Composition of model name

The model name indicates the inlet and outlet connections/joints.

(Example) G D - 4 6 P L C ( A )

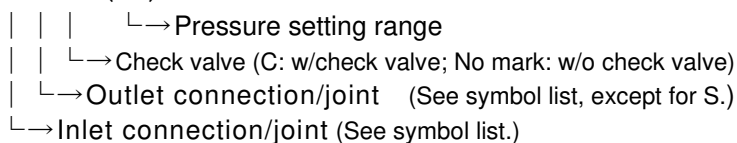

Note: "GD-46" with no symbols means parallel male threads (G1 x G1) for inlet and outlet.

Symbol list

Symbol	Connection/Joint for inlet/outlet
G	Parallel male thread (G1) for pipes attached to meter socket, etc.
P	Male thread (R3/4) compatible with cores for P&V or P
L	Female thread (Rc3/4) with built-in P&V compatible tube end core
K	Female thread (Rc3/4) without tube end core
S	Water shut off valve female thread (Rc3/4)

2 . 2 Model list

GD-46 series

Inlet connection/joint \ Outlet connection/joint			W/o union	Male union	Female union		Water shut off valve
			G	P	L	K	S
W/O union	G		GD-46	GD-46PG	GD-46LG	GD-46KG	GD-46SG
W/ Male union	P	W/O check valve	GD-46GP	GD-46PP	GD-46LP	GD-46KP	GD-46SP
		W/ check valve	GD-46GPC	GD-46PPC	GD-46LPC	GD-46KPC	GD-46SPC
W/ Female union	L	W/O check valve	GD-46GL	GD-46PL	GD-46LL	—	GD-46SL
		W/ check valve	GD-46GLC	GD-46PLC	GD-46LLC	—	GD-46SLC
	K	W/O check valve	GD-46GK	GD-46PK	—	GD-46KK	GD-46SK
		W/ check valve	GD-46GKC	GD-46PKC	—	GD-46KKC	GD-46SKC

### 3. Specifications

Nominal diameter		2 0 A
Application		City water
Inlet pressure		1.0 MPa or less
Reduced pressure	(A)	0.05~0.10MPa (Standard setting: 0.09MPa )
	(B)	0.10~0.22MPa (Standard setting: 0.20MPa )
	(C)	0.20~0.30MPa (Standard setting: 0.25MPa )
Minimum differential pressure		0.02 MPa
Maximum pressure reduction ratio		10 : 1
Working temperature	w/o pipe end core	5 ~ 9 0 °C
	w/ pipe end core	5 ~ 4 0 °C
	w/ check valve	5 ~ 6 0 °C
Min. adjustable flow rate		0.5 L/min
Rated flow	w/o check valve	50 L/ min (Pressure difference between upstream and downstream of the valve:0.10 MPa or more)
	w/ check valve	30 L/ min (Pressure difference between upstream and downstream of the valve:0.10 MPa or more)
Pressure check function		Pressure gauge joint (JIS Rc1/8)

- Pressure gauges (type A and D) are option. (0.5 MPa)  
Pressure gauge (JIS R1/8) is to be connected at the site.  
Accuracy of the pressure gauge is  $\pm 3\%$  F.S.
- Strainer has a mesh size of 60.
- Factory setting is reducing valve function.
- An incombustible material is used for heat insulating material.

#### CAUTION

Please confirm that the indications on the product correspond with the specifications of the ordered product model before use.

\* If they are different, please contact us without using the product.

4 . Dimensions

4 . 1 Dimensions and weights

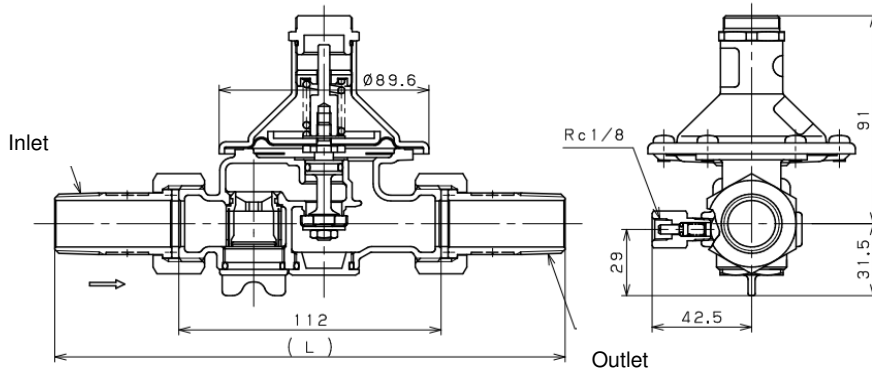

Model GD-46PP

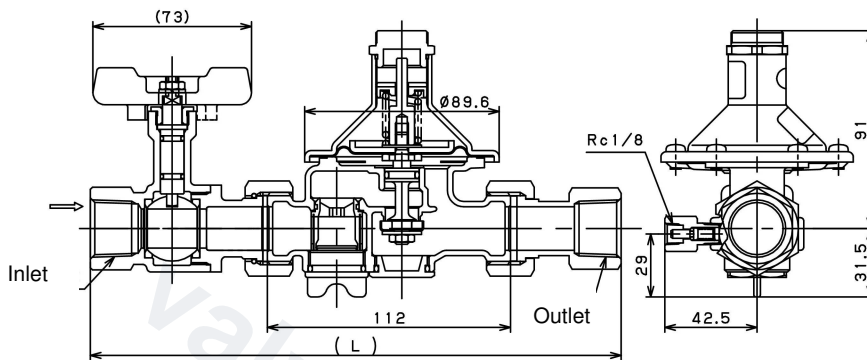

Model GD-46SK

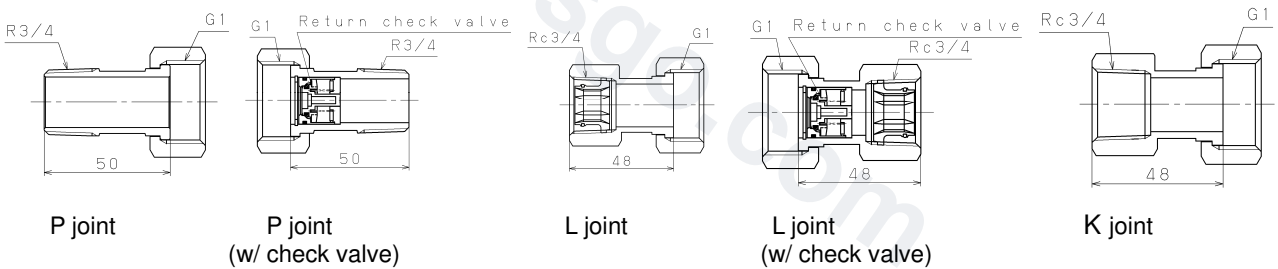

Note: Connections and joints depend on model.

Model	Joint	L	Mass (kg)
	Inlet x outlet		
GD-46	G1 x G1	—	1.0
GD-46PP·46PPC	R3/4 x R3/4	218	1.4
GD-46LL·46LLC·46KK·46KKC	Rc3/4 x Rc3/4	214	1.5
GD-46PL·46PLC·46PK·46PKC	R3/4 x Rc3/4	216	1.4
GD-46LP·46LPC·46KP·46KPC	Rc3/4 x R3/4	216	1.4
GD-46PG	R3/4 x G1	165	1.2
GD-46GP·46GPC	G1 x R3/4	165	1.2
GD-46LG·46LGC	Rc3/4 x G1	163	1.2
GD-46GL·46GLC·46GK·46GKC	G1 x Rc3/4	163	1.2
GD-46SG	Rc3/4 x G1	194.5	1.4
GD-46SP·46SPC	Rc3/4 x R3/4	247.5	1.6
GD-46SL·46SLC·46SK·46SKC	Rc3/4 x Rc3/4	245.5	1.6

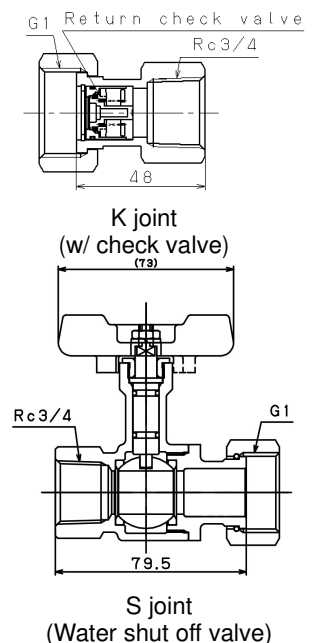

#### 4 . 2 Dimensions of heat insulating material

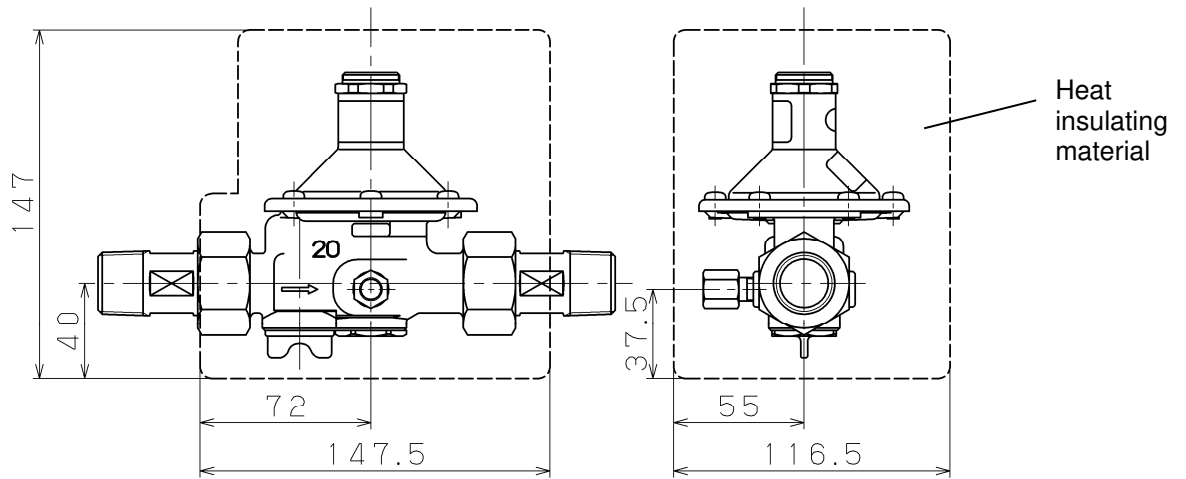

Model GD-46PP

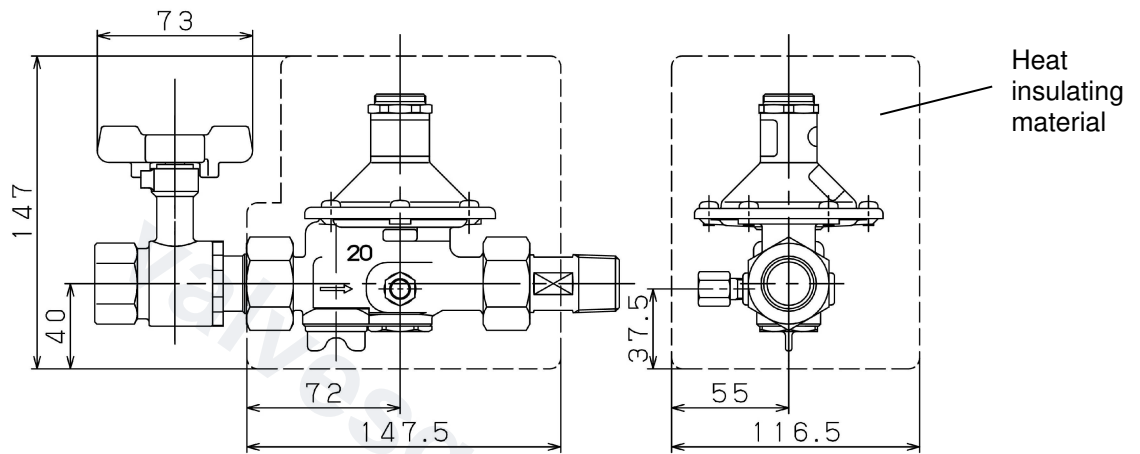

Model GD-46SP

Note: The heat insulating material is common to all products in GD-46 series. Water shut off valve has no insulating material.

#### 4 . 3 Dimensions with pressure gauge (option)

With type A pressure gauge

With type D pressure gauge

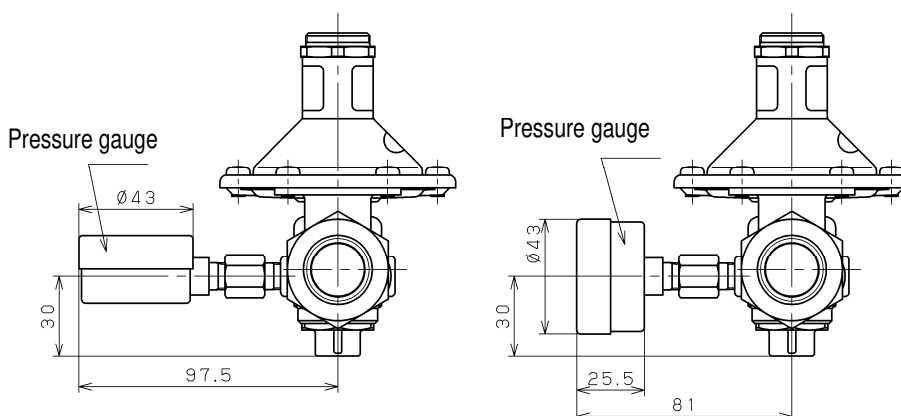

Note: Secure the space, at least, shown above before pressure adjustment. Be sure to detach the pressure gauge after pressure adjustment.

5. Flow characteristic curve

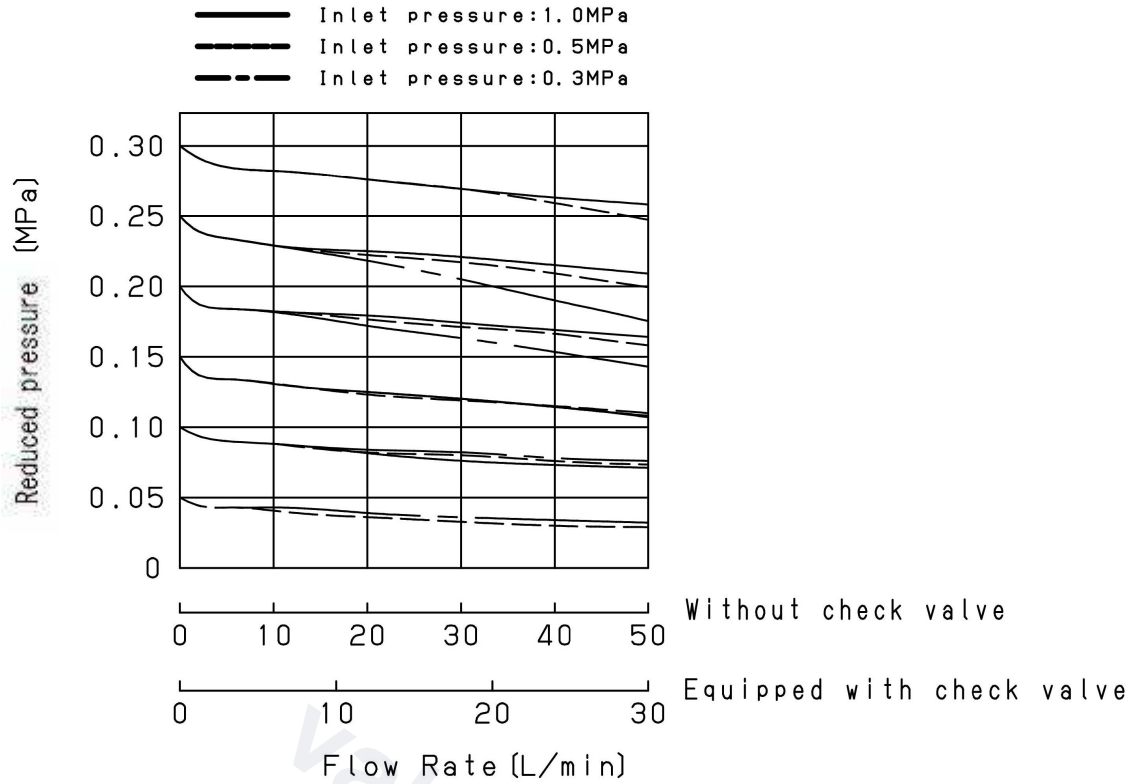

6. Noise characteristic curve (w/o check valve)

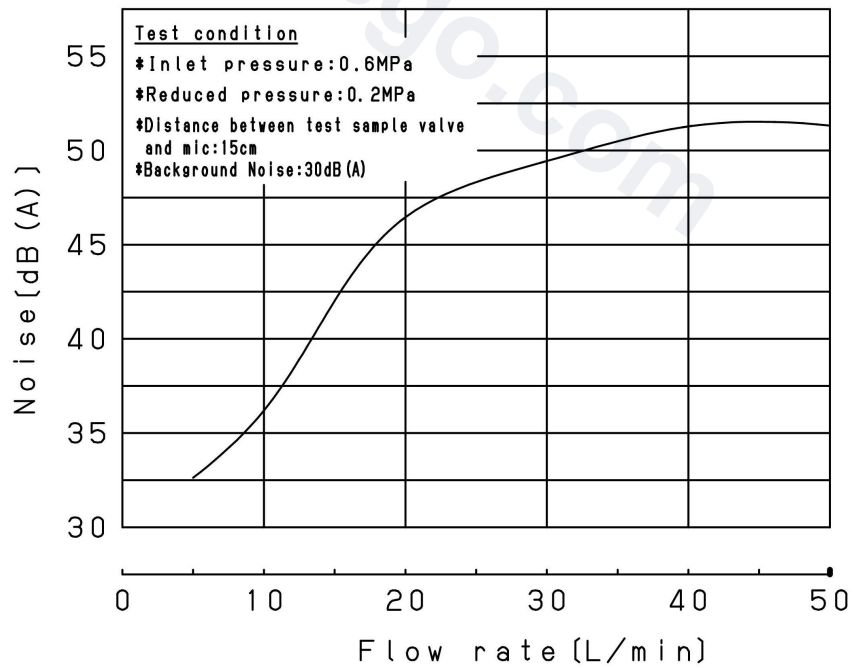

## 7 . Pressure characteristic curve

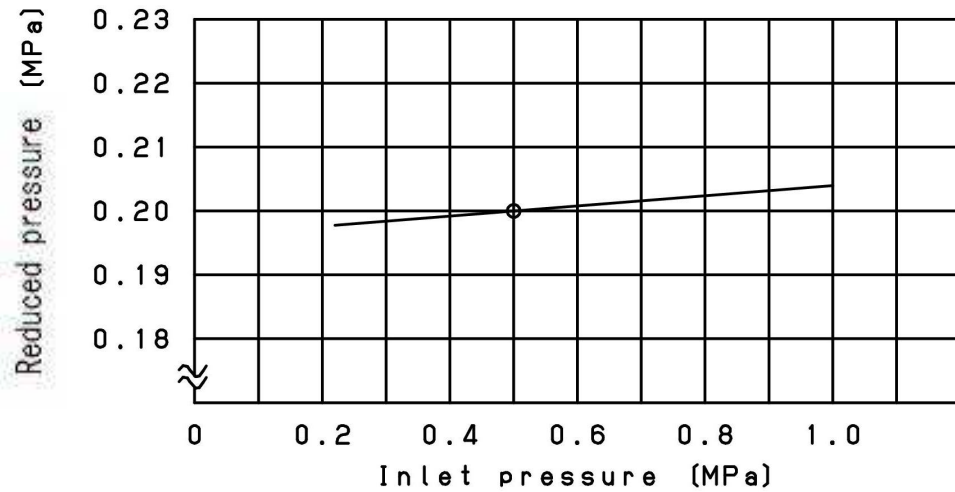

This chart shows variation in reduced pressure when the inlet pressure of 0.5 MPa is changed between 0.22 MPa and 1.0 MPa while the reduced pressure is set at 0.2 MPa.

## 8 . Operational description

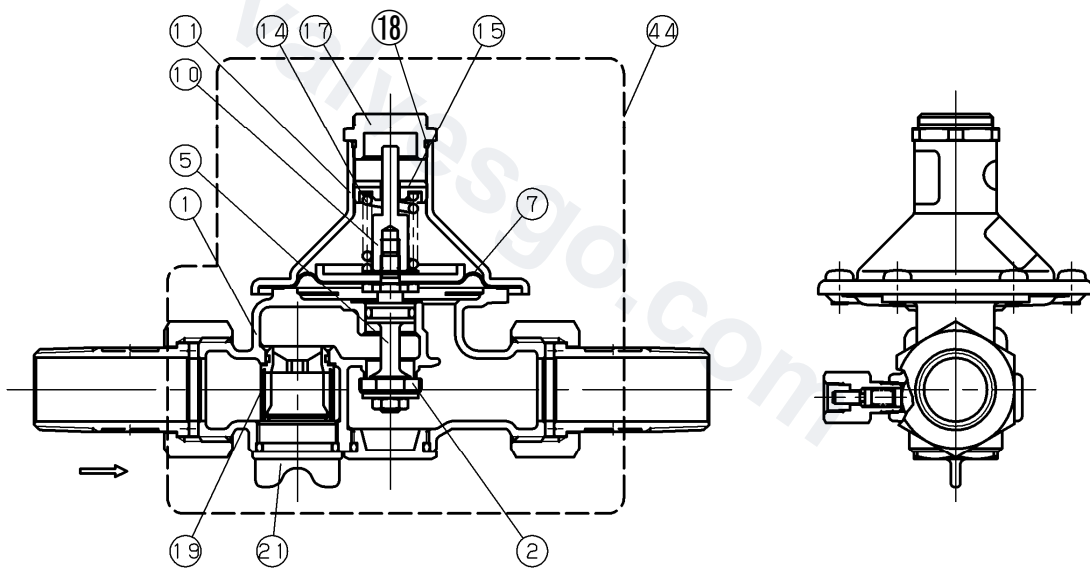

No	Name of part	No	Name of part
1	Body	15	Adjusting screw
2	Valve	17	Cap
5	Spindle	18	O-ring
7	Diaphragm	19	Strainer
10	Domed cap nut	21	Strainer cap
11	Spring cover	44	Heat insulating material
14	Adjusting spring		

Before applying fluid, the adjusting spring (14) compressed by the adjusting screw (15) presses down the diaphragm (7). The Spindle (5) opens valve (2). As water runs from the inlet through the strainer (19) and the valve top to the outlet side where water also directly applies pressure to the diaphragm (7). The reduced pressure applied to the diaphragm (7) adjusts the opening degree of the valve (2) against the force from the adjusting spring (14), keeping the reduced pressure stable.

## 9. Installation

### 9.1 Piping example

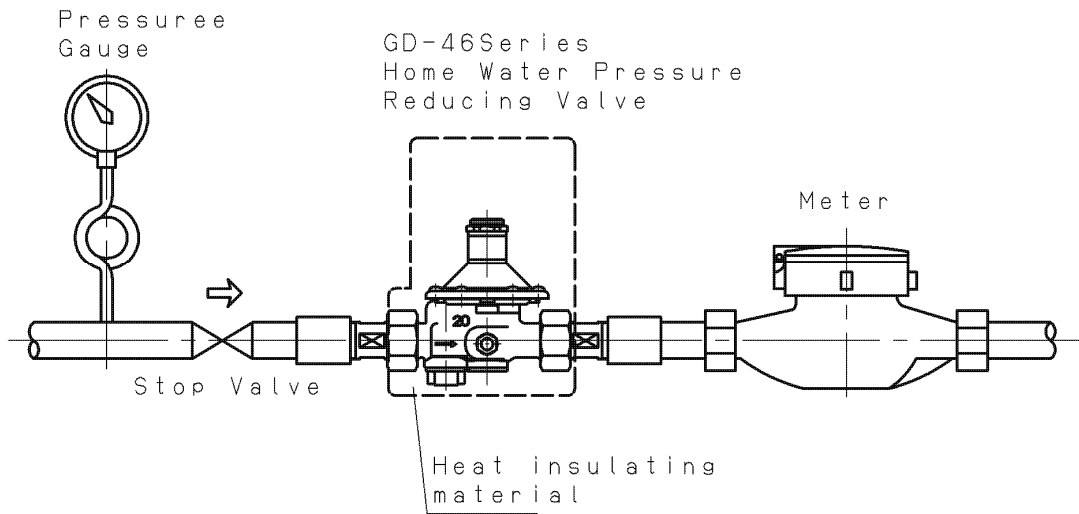

#### [Example.1]

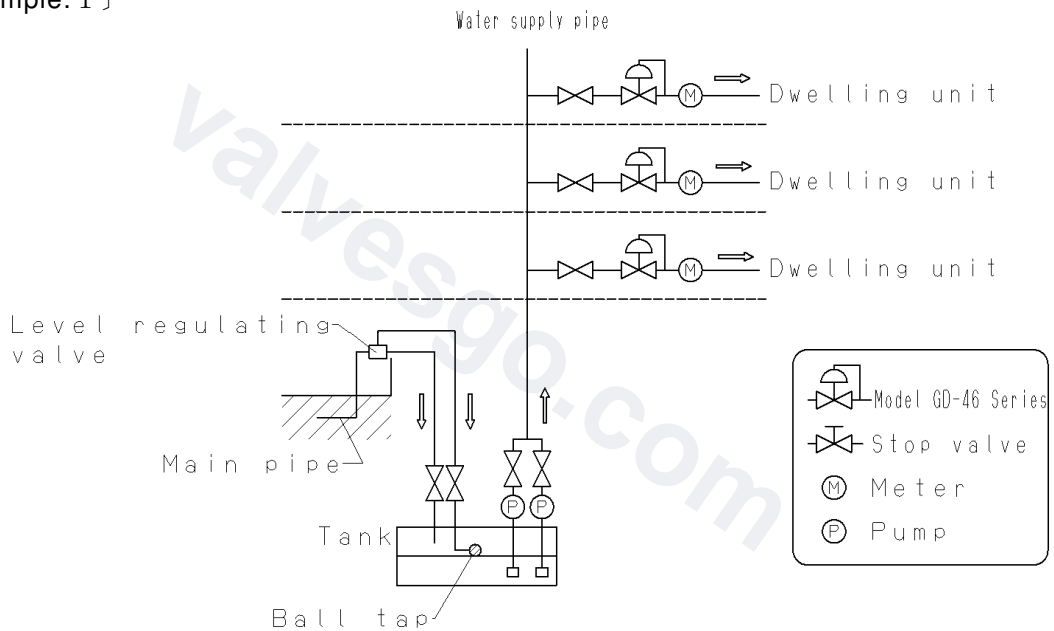

#### [Example.2]

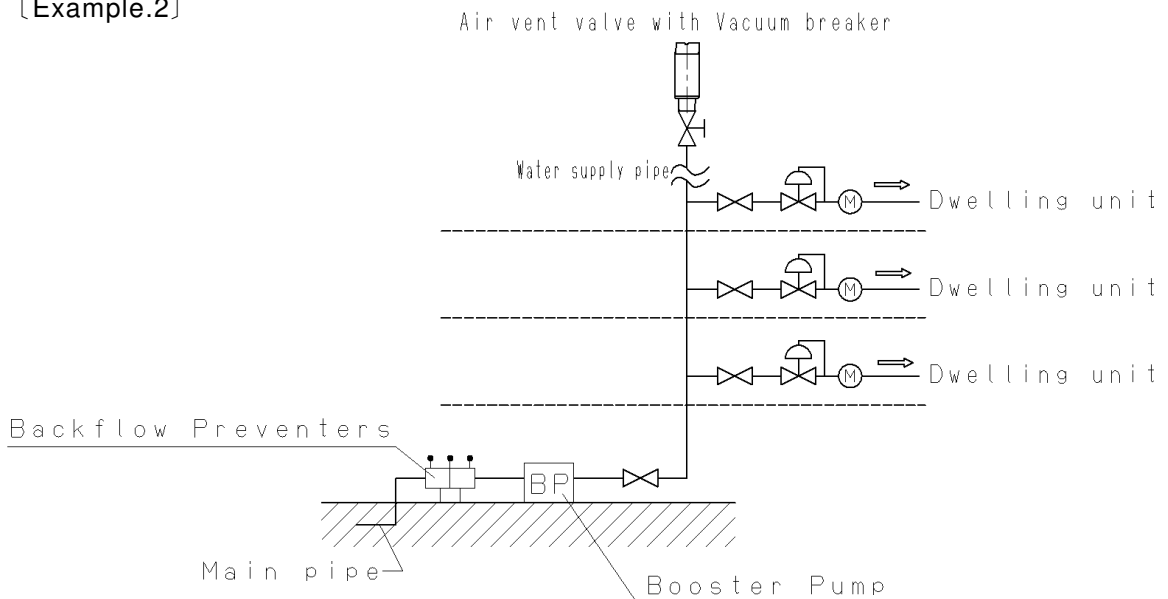

**CAUTION**

- ( 1 ) Do not disassemble the reducing valve unless it must be disassembled.  
 ※The product has been strictly inspected at the factory. Incorrectly disassembled, the reducing valve cannot function, as it should.
- ( 2 ) Before connecting the reducing valve to the piping, remove the foreign materials from the piping.  
 ※If foreign materials are introduced into the reducing valve, it cannot operate as it should and may be damaged.
- ( 3 ) When installing, check the direction of the reducing valve so that the fluid flowing and the arrow marked on the valve body are in the same direction. The product can be installed vertically or horizontally.  
 ※If installed in opposite direction, the reducing valve cannot function as it should.
- ( 4 ) To attach water shut off valve to reducing valve, make sure there is no inclination (misalignment of the piping center).  
 ※If there is an inclination (misalignment of the piping center), It causes outside leakage because the searing performance of the gasket is impaired.
- ( 5 ) When installing GD-46□□C type with the check valve, be sure to attach the supplied joint with internal check valve to the outlet side of the reducing valve.  
 ※If the joint is installed at the inlet side, the fluid cannot flow.
- ( 6 ) Secure at least the space specified in "Space required for disassembly and inspection" shown below.  
 ※Larger the space, easier the maintenance and inspection works.
- ( 7 ) When piping synthetic tube like polyvinyl chloride, never introduce the adhesive material into the product.  
 ※The adhesive material can cause the clogged strainer or damaged synthetic rubber, which may degrade the product performance.
- ( 8 ) Installing guidance on the product with internal tube end core
  - ①Do not expose the product close to the fire or hot temperature from the welding work.  
 ※ The end tube core may be thermally deformed and fail to operate as designed.
  - ②Female joint in the core  
 Water supply lining steel pipe is either "Vinyl chloride lining steel pipe for city water" or "Polyethylene resin lining steel pipe". The end tube core in the product can accommodate pipes of both types.
  - ③Cutting the pipe  
 When cutting the pipe, the cutting angle must be perpendicular to the length of the pipe. Use an automatic metal sawing machine, automatic circular sawing machine, or the like.  
 Notes: 1 . Do not use pipe cutter or gas cutting, arc cutting or high-speed wheel cutting technology.  
 2 . Completely remove oil from the pipe.  
 ※ The oil may damage the synthetic rubber, degrading its performance.
  - ④Chamfering the pipe  
 Plane the burrs off the pipe inside using a chamfering tool such as scraper.
  - ⑤Threading the pipe  
 Cut threads on the pipes according to JIS specifications. Verify the thread by using a screw-thread gauge.  
 ※Note that a screw-thread smaller than the specified value may damage the core.
  - ⑥Applying seal material  
 Apply corrosion resistant seal material evenly to the male threads of the pipe and the pipe end.
  - ⑦Connecting pipes  
 When jointing pipes, refer to the standard number of screwed threads and thread depth shown below.

Normal diameter	Standard number of screwed threads (ridges)	Standard screwed thread depth (mm)	Standard tightening torque (N · m)
20A	6	11	60

- ( 9 ) Use the polystyrene foam as the thermal insulating material.

- (10) The band on the insulating material also serves as instruction. Attach it to the product after piping for future reference.
- (11) To attach water shut off valve and union joint to the reducing valve, fasten the union nut by hand till it touches the gasket (①), and then screw it in by approximately 1/3 turn (②), as shown below.  
 ※Do not apply a torque more than the above-specified. Overtightening causes outside leakage.

After screwing in by approx. 1/3 turn from ①.

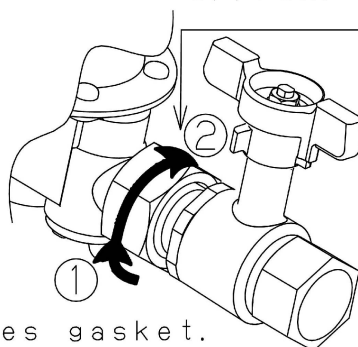

Union touches gasket.

- (12) When installed in a closed piping, the reducing valve is damaged due to volume expansion of the fluid caused by temperature increase.
- (13) If fluid remains inside the reducing valve for a long time, the sliding parts become stuck resulting in malfunction of the valve.
- (14) Do not apply excessive load, torque or vibration to the reducing valve.
- (15) Do not connect the reducing valve to a dissimilar metal pipe that can cause a potential difference, to avoid corrosion of the valve or its parts.
- (16) Choose a proper reducing valve considering usage conditions including use frequency and the durability of the valve.
- (17) In the case where a cross-linked polyethylene pipe with casing is used for a header, support the pipe with metal fittings. Otherwise, outside leakage may occur due to excessive load applied to the union packing.

- Space required for disassembly and inspection

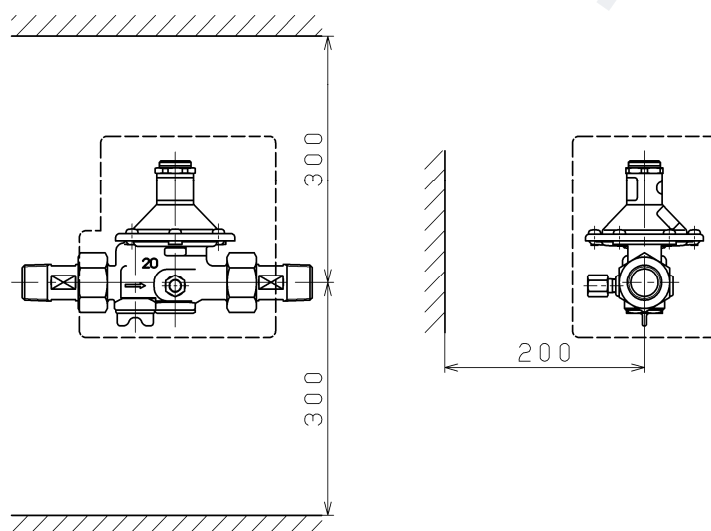

### 9. 3 Precaution and procedure for water pressure inspection

#### CAUTION

- (1) Wear protective gloves e.g. cotton work gloves when removing/installing the cap (17).  
※Hand protection is required.
- (2) If perform pneumatic inspection with the concave position upward (Fig.1), do not sprinkle forming liquid to the O-ring (18).  
※Since the O-ring (18) built into the cap uses a water-absorbent O-ring, the O-ring may seal when the cap is returned to the original position (making planar position upward), causing malfunction.

- (1) Be sure to check that there is no internal pressure in the piping before water pressure inspection. If internal pressure remains inside, remove it.
- (2) Remove the cap and turn it out (make concave portion upward), and screw it firmly onto the spring cover. (Fig.1)  
※Do not screw the cap when there is internal pressure.
- (3) On water pressure inspection, be sure to check the concave portion of the cap is screwed in upward direction, and conduct the water pressure inspection at 1.75 MPa or less.
- (4) Take the internal pressure, and be sure to return the cap to the original position (making planar position upward) after water pressure inspection.(Fig.2)  
※If the cap does not return to its original position, the product cannot functions as a pressure reducing valve.

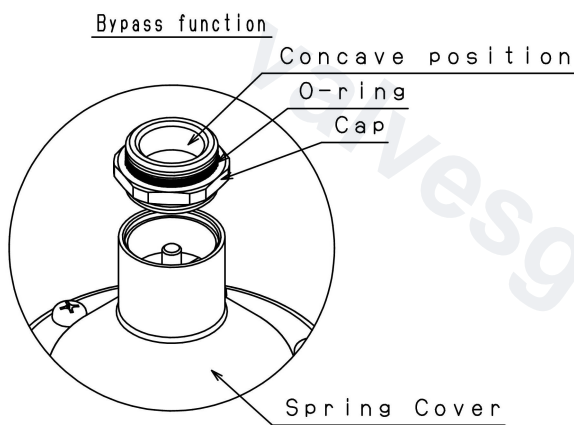

Fig.1.

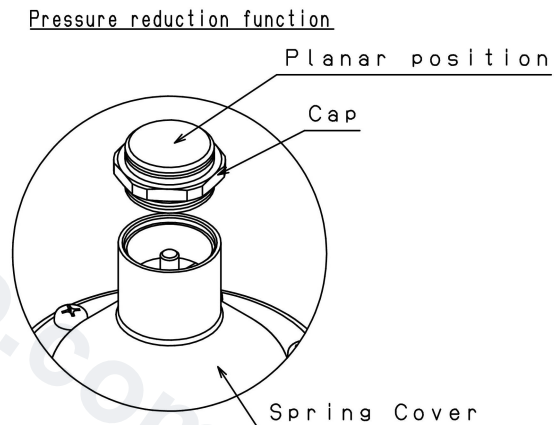

Fig.2.

## 1 0 . Operation

### 1 0 . 1 Precaution for operation

#### WARNING

Never directly touch the product with bare hands when hot fluid is running.  
※Hot fluid may cause burns.

#### CAUTION

- ( 1 ) Do not disassemble the product unnecessarily. The product is adjusted to the standard set pressure at factory before shipment. In the case the adjustment is required, it must be done by an experienced professional and the set pressure must be within the range specified on the label attached to the product. Refer to "10.2 Precaution and procedure for pressure adjustment".
- ( 2 ) Confirm that the flat surface of the cap is facing up.※The product does not work as a pressure reducing valve with the concave face of the cap upward.  
The concave face has an O-ring on its circumference.

The set pressure may change according to ambient temperature or fluid temperature.  
Avoid exposing the product and the piping to the direct sunshine.

### 1 0 . 2 Precaution and procedure for pressure adjustment

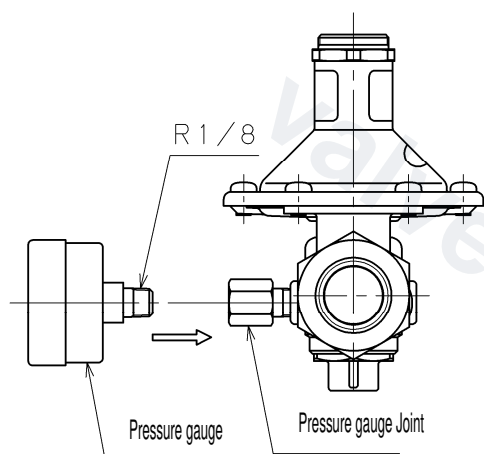

Fig. 3

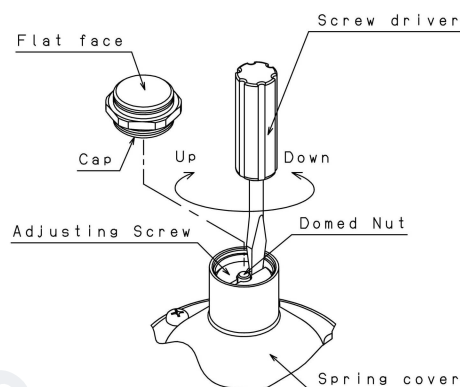

Fig. 4

- ( 1 ) Screw the pressure gauge into the pressure gauge joint. (Fig. 3)
- ( 2 ) Remove the cap. By checking the pressure gauge, turn the adjusting screw to adjust the reduced pressure to a desired level. (Fig.4)
  - The reduced pressure increases when the adjusting screw is turned clockwise.
  - The reduced pressure decreases when the adjusting screw is turned counterclockwise.

Note: Use a keystone tip screwdriver of 4.5 to 6 mm in nominal width for slotted head screws. Set the screwdriver in the slot of the adjusting screw avoiding the domed cap nut attached in the center of the screw, and adjust the reduced pressure. If pressure adjustment is difficult to make, please contact us.

- ( 3 ) After reduced pressure adjustment, attach the cap with the flat face up.

#### CAUTION

- ( 4 ) Connect the pressure gauge on the spot.  
Be sure to detach the pressure gauge after making adjustment and checking the pressure.  
※If the pressure reducing valve is used with the pressure gauge attached, the pressure gauge joint may be damaged (stress corrosion cracking) depending on the usage environment, causing outside leakage. If the reducing valve needs to operate with a pressure gauge connected, screw the gauge directly into the valve body and do not use a pressure gauge joint.

1 1 . Maintenance

1 1 . 1 Troubleshooting guide

Problem	Possible cause	Corrective action
Reduced pressure is higher than the set pressure	<ol style="list-style-type: none"> <li>The cap (17) is left in water pressure check status.</li> <li>Diaphragm (7) is damaged.</li> <li>Spindle O ring (6) is damaged.</li> <li>Foreign object is pinched between valve (2) and valve seat. Valve or valve seat is damaged.</li> </ol>	<ol style="list-style-type: none"> <li>Invert the cap (17) so that its flat surface is on upside.</li> <li>Replace the diaphragm with a new set.</li> <li>Replace the diaphragm with a new set</li> <li>Remove the foreign materials. If the valve (2) is damaged, replace it with a new one. If the valve seat is damaged, replace the valve body (1) with a new one.</li> </ol>
Low flow rate	<ol style="list-style-type: none"> <li>Sliding movement of valve stem O ring (5) is disturbed by water scale, deposits, etc.</li> <li>Strainer (19) is clogged.</li> <li>Pressure is set low.</li> <li>Water shut off valve (41) is closed.</li> </ol>	<ol style="list-style-type: none"> <li>Clean the inside of the valve body and replace the diaphragm with a new set.</li> <li>Clean the strainer (19).</li> <li>Adjust the pressure following the adjusting steps.</li> <li>Open the water shut off valve (41).</li> </ol>
External leakage	<ol style="list-style-type: none"> <li>Set screw (23) is loosened.</li> <li>Valve cap (12) is loosened.</li> <li>O ring (13) is damaged.</li> <li>Strainer cap (21) is loosened.</li> <li>O ring (22) is damaged.</li> <li>Union nut (33), (34) or (41) is loosened.</li> <li>Gasket (30) or (43) is damaged.</li> <li>Pressure gauge joint (24) is loosened.</li> <li>Foreign object is stuck in pressure gauge joint (24).</li> </ol>	<ol style="list-style-type: none"> <li>Retighten the round head screw (23).</li> <li>Retighten the valve cap (12).</li> <li>Replace the O ring (13) with a new one.</li> <li>Retighten the strainer cap (21).</li> <li>Replace the O ring (22) with a new one.</li> <li>Retighten the union nut (33), (34) and (41).</li> <li>Replace the gasket (30),(43).</li> <li>Remove the pressure gauge joint (24). Apply seal tape to the threads and attach the joint to the valve body (1).</li> <li>Replace the pressure gauge joint (24) with a new one.</li> </ol>

1 1 . 2 Precaution for maintenance and inspection

**⚠ WARNING**

- (1) Completely discharge the pressure inside of the product and piping before disassembly and inspection. Disassembly and inspection must be conducted by an experienced professional.  
※Residual pressure, if any, may blow out the fluid, causing bodily injury or contamination on surroundings.
- (2) Never touch the product with bare hands when hot fluid is used.  
※Hot fluid may cause burns.

**⚠ CAUTION**

- (1) For troubles other than those described in 11.1 Troubleshooting guide, contact us.
- (2) During disassembling, internal fluid flows out. Discharge it into a suitable container.  
※Fluid spills will contaminate surroundings.
- (3) When starting operation after interval of an extended period, turn on a faucet and check the water supply pressure.  
※In case of a trouble such as poor water pressure, adjustment work must be done by an experienced professional.
- (4) Service life of the product is about 8 years. Parts made of synthetic rubber are consumable parts. Although their service lives vary depending on conditions of use, replace the following parts when the time below comes in order to maintain the optimal performance of the product.

Serviceable life	Parts name/number
3 years	Diaphragm set, Valve (2)
5 years	O rings (13),(22),(18) Gaskets (30),(43)

※ Refer to “12. Exploded drawing” for the numbers in brackets.

### 1 1 . 3 Disassembling

- ( 1 ) Remove the cap (17). Unscrew the adjusting screw (15) to free the adjusting spring (14) from the load.
- ( 2 ) Remove 6 round head screws (23) from the spring cover (11). Remove the cover (11) and adjusting spring (14).
- ( 3 ) Remove the valve cap (12) (nominal designation 27).
- ( 4 ) While holding the hexagon head (nominal designation 10) of the cap nut (10), remove the hexagon nut (4) (nominal designation 10) from the valve(2).
- ( 5 ) Remove the set of diaphragm, valve (2) and washer (3).

### 1 1 . 4 Troubleshooting

- ( 1 ) Reduced pressure exceeds the predetermined pressure:  
Check the status of the cap (17). If it is OK, follow the procedure described in 11.3 Disassembling, steps (1)-(5) and check the diaphragm set, valve body and valve.
- ( 2 ) Flow is low at a faucet:  
Check the water shut off valve (41), strainer (19) and the pressure setting. If they are OK, follow the procedure described in 11.3 Disassembling, steps (1)-(5) and check the diaphragm set and valve body.
- ( 3 ) External leakage:  
Locate the leaking component and secure or retighten the related parts. If the leakage persists, replace the associated O ring or gasket.

### 1 1 . 5 Precaution for assembly

#### CAUTION

- |   |
|---|
| <ol style="list-style-type: none"><li>( 1 ) Confirm that the inside the valve body and components are free from foreign material deposition.<br/>※Foreign objects degrade performance and must be removed.</li><li>( 2 ) Confirm that the valve and O ring are free from scar and damage.<br/>※ Damaged component degrades system performance and must be replaced.</li><li>( 3 ) Apply a coat of silicone grease (harmless to humans) to the O ring.<br/>※ Silicone grease protects the surface of the O ring.</li></ol> |
|---|

Assemble the unit in the reversal order of the disassembly.

Set screws (23) on the spring cover (11) must be tightened in a crisscross pattern with uniform torque.

## 1 1 . 6 Precaution for cleaning and how to clean

### ⚠ WARNING

- (1) Completely discharge the pressure inside of the product and piping before disassembly and inspection. Disassembly and inspection must be conducted by an experienced professional.
  - ※Residual pressure, if any, may blow out the fluid, causing bodily injury or bringing pollution to equipment and facilities.
- (2) Never touch the product with bare hands when hot fluid is used.
  - ※Hot fluid may cause burns.

### ⚠ CAUTION

- (1) Clean the strainer at regular intervals, once or twice per year.
  - ※Too many scales decrease flow rate and thus performance.
- (2) When removing the strainer cap, place a suitable receiver under it. See Fig.6.
- (3) When cleaning the strainer, do not remove it from the strainer cap.
  - ※Disassembling the strainer may cause damage to it.

- (1) Close the slice valve at the inlet and open a faucet located at the end of the piping to completely relieve the product internal pressure.
- (2) Turn the strainer cap counterclockwise until it is disengaged.
- (3) With the strainer cap still attached to the strainer, wash them in water to remove the deposited scales.
- (4) Attach the set of strainer and strainer cap to the valve body.
- (5) Open the slice valve at the inlet. Check the strainer cap for leakage. If leaking, replace the O ring with a new one.
- (6) Check the flow rate at the faucet located at the end of the system.

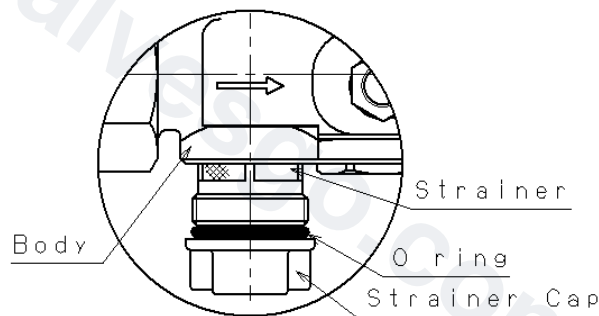

fig.5

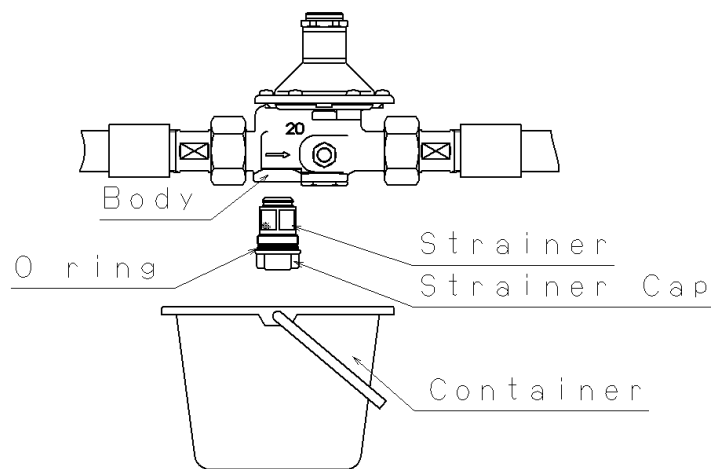
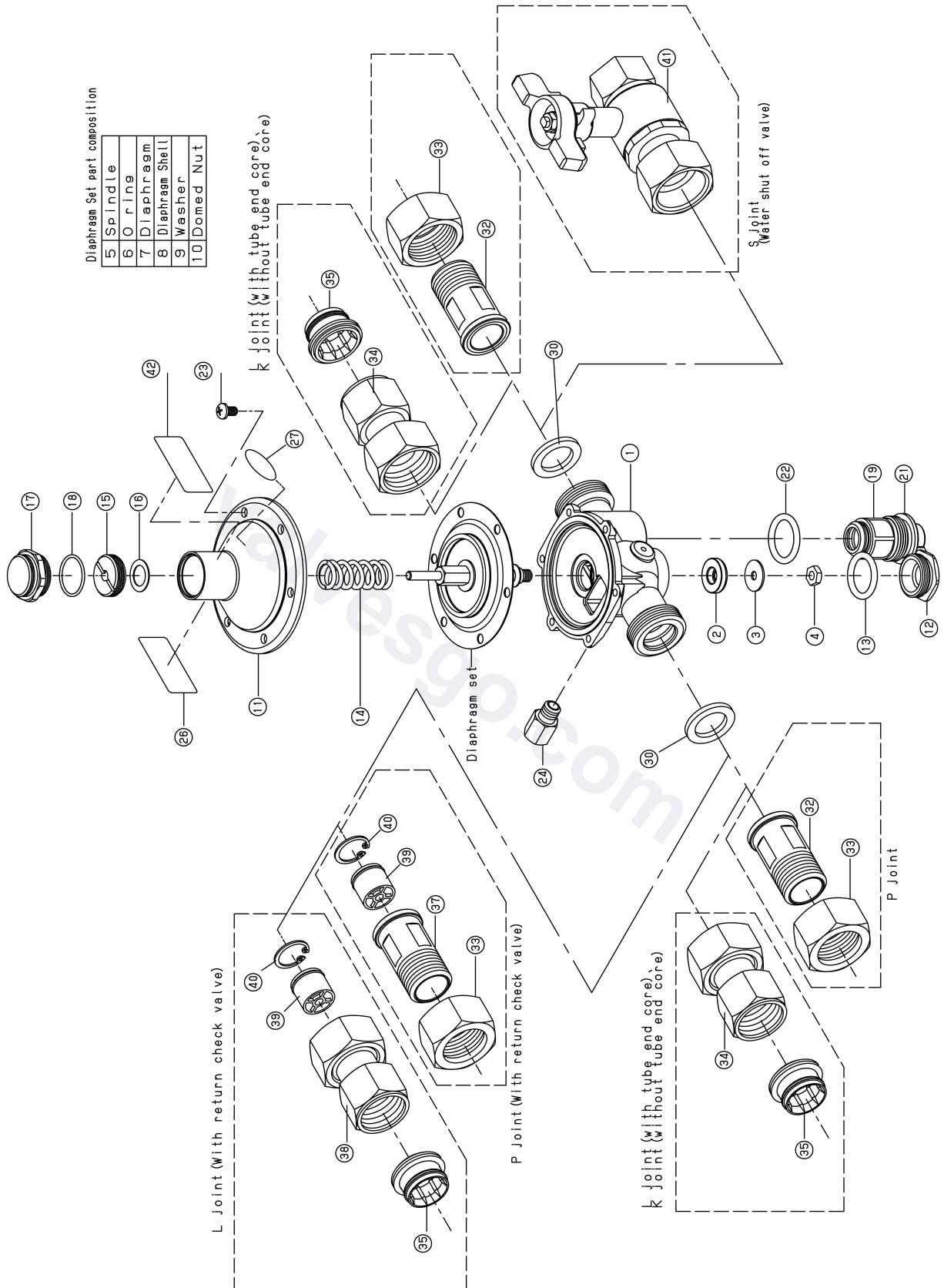

fig.6

1 2 . Exploded drawing

● Refer to the following page for a part table.



● Part table

Part No.	Name of Part	Part No.	Name of Part
1	Body	22	O ring
2	Valve	23	Set Screw
3	Washer	24	Pressure Gauge Joint
4	Nut	26	Label
5	Spindle	27	Label
6	O ring	30	Gasket
7	Diaphragm	32	Union Nipple
8	Diaphragm Shell	33	Union Nut
9	Washer	34	Union Socket
10	Domed Cap Nut	35	Tube end core
11	Spring Cover	37	Nipple for Check valve
12	Valve Cap	38	Socket for Check valve
13	O ring	39	Check valve
14	Adjusting Spring	40	Retaining Ring C Type
15	Adjusting Screw	41	Water Shut off Valve
16	Washer	42	Label
17	Cap		
18	O ring		
19	Strainer		
21	Strainer Cap		

### 1 3 . Packing

#### 1 3 . 1 Packing figure

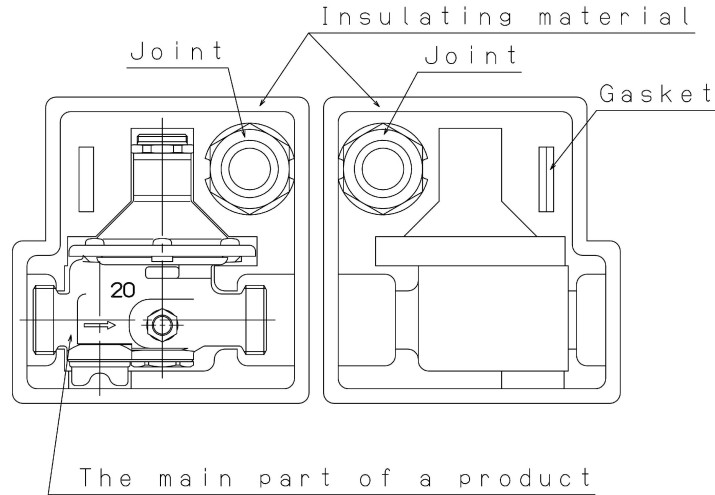

#### 1 3 . 2 Contents of packing

Model	The main part of a product	Joint						Gasket	Pressure gauge (Option)
		P joint	L joint	K joint	P joint with check valve	L joint with check valve	K joint with check valve		
GD-46	1	—	—	—	—	—	—	—	(1)
GD-46PP	1	2	—	—	—	—	—	2	(1)
GD-46LL	1	—	2	—	—	—	—	2	(1)
GD-46KK	1	—	—	2	—	—	—	2	(1)
GD-46PL	1	1	1	—	—	—	—	2	(1)
GD-46LP	1	1	1	—	—	—	—	2	(1)
GD-46PK	1	1	—	1	—	—	—	2	(1)
GD-46KP	1	1	—	1	—	—	—	2	(1)
GD-46PG	1	1	—	—	—	—	—	1	(1)
GD-46GP	1	1	—	—	—	—	—	1	(1)
GD-46LG	1	—	1	—	—	—	—	1	(1)
GD-46GL	1	—	1	—	—	—	—	1	(1)
GD-46KG	1	—	—	1	—	—	—	1	(1)
GD-46GK	1	—	—	1	—	—	—	1	(1)
GD-46PPC	1	1	—	—	1	—	—	2	(1)
GD-46LLC	1	—	1	—	—	1	—	2	(1)
GD-46PLC	1	1	—	—	—	1	—	2	(1)
GD-46LPC	1	—	1	—	1	—	—	1	(1)
GD-46KKC	1	—	—	1	—	—	1	2	(1)
GD-46PKC	1	—	—	—	—	—	1	2	(1)
GD-46KPC	1	—	—	1	1	—	—	2	(1)
GD-46GPC	1	—	—	—	1	—	—	1	(1)
GD-46GLC	1	—	—	—	—	1	—	1	(1)
GD-46GKC	1	—	—	—	—	—	1	1	(1)
GD-46SG	1	—	—	—	—	—	—	—	(1)
GS-46SP	1	1	—	—	—	—	—	1	(1)
GD-46SL	1	—	1	—	—	—	—	1	(1)
GD-46SK	1	—	—	1	—	—	—	1	(1)
GD-46SPC	1	—	—	—	1	—	—	1	(1)
GD-46SLC	1	—	—	—	—	1	—	1	(1)
GD-46SKC	1	—	—	—	—	—	1	1	(1)

• The water shut off valve is another packing.

---

## Warranty Information

---

1. Limited warranty

This product has been manufactured using highly-advanced techniques and subjected to strict quality control. Please be sure to use the product in accordance with instructions on the manual and the label attached to it.

Yoshitake warrants the product to be free from any defects in material and workmanship under normal usage for a period of one year from the date of receipt by the original user, but no longer than 24 months from the date of shipment from Yoshitake's factory.

2. Parts supply after product discontinuation

This product may be subject to discontinuation or change for improvement without any prior notice. After the discontinuation of the product, Yoshitake supplies the repair parts for 5 years otherwise individually agreed.

3. This warranty does not cover the damage due to any of below:

- (1) Valve seat leakage or malfunction caused by foreign substances inside piping.
- (2) Improper handling or misuse.
- (3) Improper supply conditions such as abnormal water pressure/quality.
- (4) Water scale or freezing.
- (5) Trouble with power/air supply.
- (6) Any alteration made by other than Yoshitake.
- (7) Use under severe conditions deviating from the design specifications (e.g. in case of corrosion due to outdoor use).
- (8) Fire, flood, earthquake, thunder and other natural disasters.
- (9) Consumable parts such as O-ring, gasket, diaphragm and etc.

Yoshitake is not liable for any damage or loss caused by malfunction or defect of the product.

**YOSHITAKE** 