

Model GP-1000 Series
PRESSURE REDUCING VALVE
Installation & Operation Manual

Please read this bulletin thoroughly before using the pressure reducing valve, so that you may do so correctly and safely. Please carefully store this bulletin in a handy place.

—————The following safety symbols are used in this manual. —————

⚠ Warning

This symbol indicates a potentially hazardous situation that, if not avoided, could result in death or serious injury.

⚠ Caution

This symbol indicates a hazardous situation that, if not avoided, may result in minor or moderate injury. (“Caution” may also be used to indicate other unsafe practices or risks of property damage.)

Contents

1. Features	1
2. Specifications	1
3. Dimensions and Weights.....	2
4. Operation.....	3
5. Nominal Size Selection Method	
5.1 Specifications selection chart.....	4
5.2 Safety valve setting pressure.....	4
5.3 Characteristics chart	4
5.4 Nominal size selection chart	5
5.5 Nominal size selection calculation formula	6
6. Installation	
6.1 Example of piping	6
6.2 Precautions during installation	7
7. Operating Procedure	
7.1 Precautions during operation	8
7.2 Adjustment procedures	8
8. Maintenance Procedure	
8.1 Troubleshooting	9
8.2 Precautions during maintenance and inspection	10
8.3 Disassembly.....	10
8.4 Precautions during reassembly.....	11
8.5 Exploded drawing	12
After Sale Service	



1. Features

GP-1000 Series pressure reducing valves for steam are pilot-operated valves which can be used with confidence for small to large flow rate, in a host of applications ranging from building utilities systems, air-conditioning systems, and factory systems, etc.

2. Specifications

Model	GP-1000	GP-1010	GP-1000SS	GP-1000H	GP-1002	GP-1012
Connection	Flanged (JIS 10K FF)	JIS Rc Screw	Flanged (JIS 10K FF)	Flanged (JIS 16K FF)	Flanged (JIS 10K FF)	JIS Rc Screw
Nominal size	15~100A	15~50A	15~100A	15~100A	15~100A	15~50A
Application	Steam					
Inlet pressure	0.1~1.0 MPa			0.1~1.6 MPa	0.1~0.5 MPa	
Reduced pressure	0.05~0.9 MPa			0.05~0.9 MPa 0.9~1.4 MPa	0.03~0.15 MPa	
	90% or less of inlet pressure (gauge pressure)					
Min. differential pressure	0.05 MPa					
Max. pressure reducing ratio	20:1					
Max. temperature	220°C					
Valve seat leakage	0.01% or less of rated flow					
Material	Body	Ductile cast iron	Stainless steel	Ductile cast iron		
	Valve	Stainless steel				
	Valve seat	Stainless steel				
	Piston/Cylinder	Brass or Bronze	Stainless steel		Brass or Bronze	
	Gasket	Non asbestos				
Body hydraulic test	2.0 MPa			3.2 MPa	1.0 MPa	

- Stainless steel main components (piston & cylinder) are also available.(GP-1□□□S)
- All stainless steel types are also available for GP-1000.
- Adjusting handle types are also available for GP-1000 and GP-1010.(GP-1001,1011)

⚠ Caution

- (1) Please collate with attached nameplate and specification of ordered model.
 ※Please consult factory in case they do not match each other.

3. Dimensions and Weights

- GP-1000, 1000H, 1002

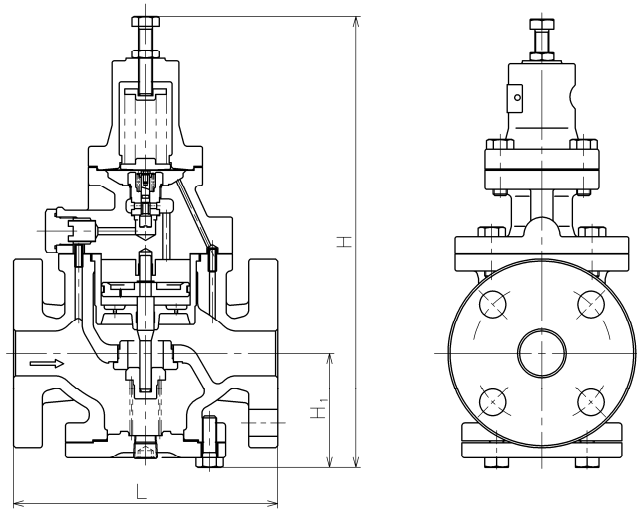

(mm)

Size	L	H	H ₁	Weight (kg)
15A	150	285	64	8.0
20A	155	285	64	8.5
25A	160	300	67	10.0
32A	190	323	82	14.0
40A	190	323	82	14.5
50A	220	347	93	20.0
65A	245	357	100	30.0
80A	290	404	122	35.0
100A	330	450	144	52.5

- GP-1010, 1012

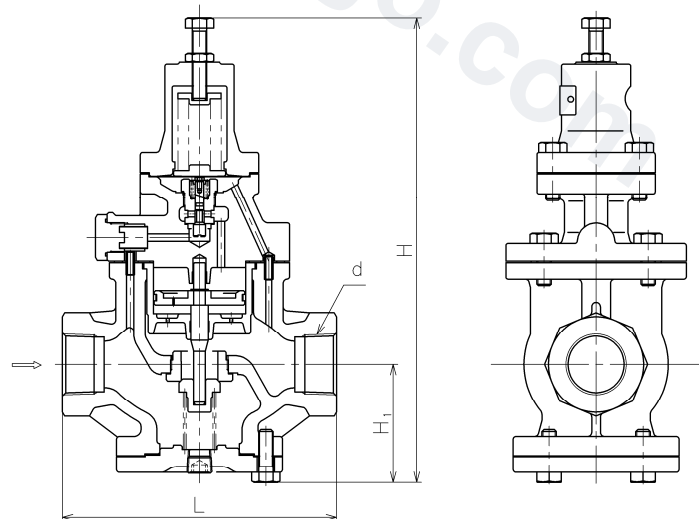

(mm)

Size	d	L	H	H ₁	Weight (kg)
15A	Rc 1/2	150	285	64	7.0
20A	Rc 3/4	155	285	64	7.0
25A	Rc 1	160	300	67	8.5
32A	Rc 1-1/4	190	323	82	12.0
40A	Rc 1-1/2	190	323	82	12.5
50A	Rc 2	220	347	93	18.0

4. Operation

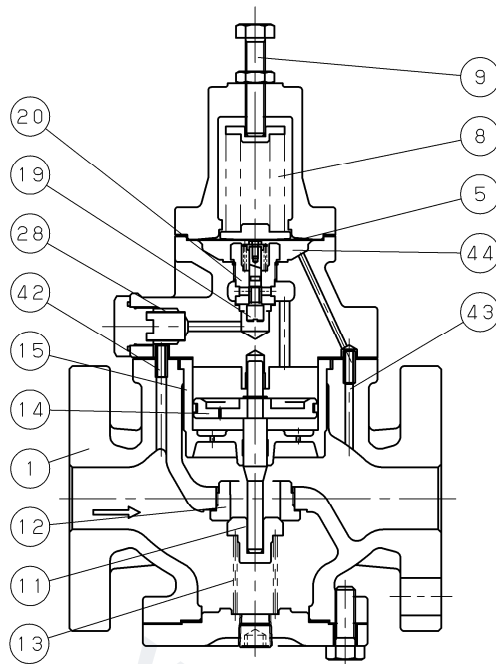

No.	Parts name
1	Body
5	Diaphragm
8	Adjusting spring
9	Adjusting screw
11	Main valve
12	Main valve seat
13	Main valve spring
14	Piston
15	Cylinder
19	Pilot valve
20	Pilot valve seat
28	Strainer
42	Inlet press. passage
43	Reduced press. Sensing port
44	Diaphragm chamber

The pressure-reducing valve reduces pressure by the throttling the valve. The valve is composed of the main valve and main valve seat for throttling, and adjusting spring, diaphragm, pilot valve, and piston for pressure sensing and activation.

- (1) When the pressure-reducing valve is mounted correctly, releasing the compression of adjusting spring [8] allows the spring to close main valve [11] and pilot valve [19]. Slowly open the gate valve and allow the high-pressure fluid to flow in. Inlet pressure is applied to the downside of the main valve. High-pressure fluid passes through strainer [28] via inlet pressure passage [42] to also apply inlet pressure to the downside of the pilot valve.
- (2) Turning adjusting screw [9] clockwise compresses the spring, which flexes diaphragm [5] to open the pilot valve.
- (3) Inlet pressure via inlet pressure passage and pilot valve enters the upside of the piston. The pressure overrides the pressure on the downside of the main valve and the load of main valve spring [13], to open the main valve. The fluid then begins to flow from the inlet side.
- (4) Reduced pressure is led to diaphragm chamber [44] via reduced pressure sensing port [43]. The diaphragm receives the reduced pressure to be balanced with the adjusting spring load, and control the pilot valve travel.
- (5) The change of pilot valve travel changes the flow rate of fluid to the upside of the piston, and controls the main valve travel to obtain appropriate reduced pressure.

5. Nominal Size Selection Method

5.1 Pressure reducing valve specification selection chart

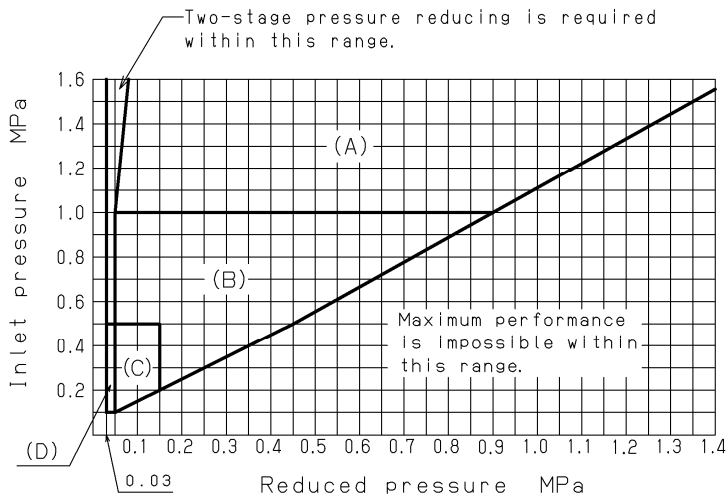

Find the intersection point of the inlet and reduced pressures. The GP-1000 series valves are suitable within range (A), (B), (C), and (D).

- Range (A) : GP-1000H
- Range (B) : GP-1000H, GP-1000(1010)
- Range (C) : GP-1000H, GP-1000(1010), GP-1002(1012)
- Range (D) : GP-1002(1012)

5.2 Safety valve setting pressure

Reduced pressures (MPa)	Safety valve setting pressure (MPa)
0.03~0.1	Reduced pressures + more than 0.05
0.1~0.4	Reduced pressures + more than 0.08
0.4~0.6	Reduced pressures + more than 0.1
0.6~0.8	Reduced pressures + more than 0.12
0.8~1.4	Reduced pressures + 15%

5.3 Characteristics chart

(1) Flow rate characteristics chart

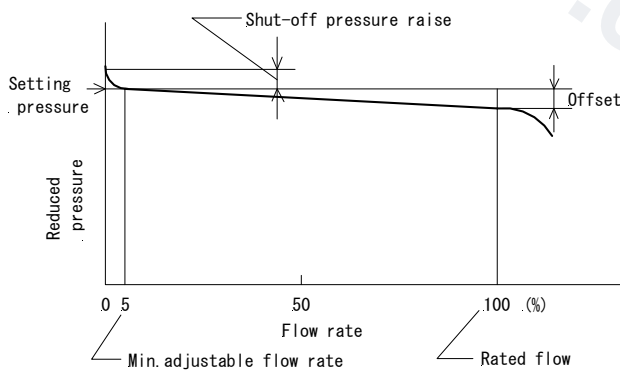

- Shut-off pressure raise : 0.02 MPa or less
- Offset : 0.03 MPa or less
(Setting pressure: 0.03~0.1 MPa)
: 0.05 MPa or less
(Setting pressure: 0.1~1.4 MPa)

(2) Pressure characteristics chart

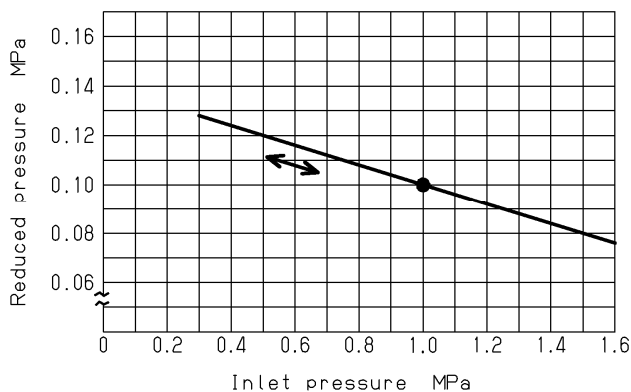

Reduced pressure is set to 0.1 MPa when inlet pressure is 1.0 MPa. The chart indicates a variation in reduced pressure when the inlet pressure is changed from 1.6 to 0.3 MPa.

5.4 Nominal size selection chart

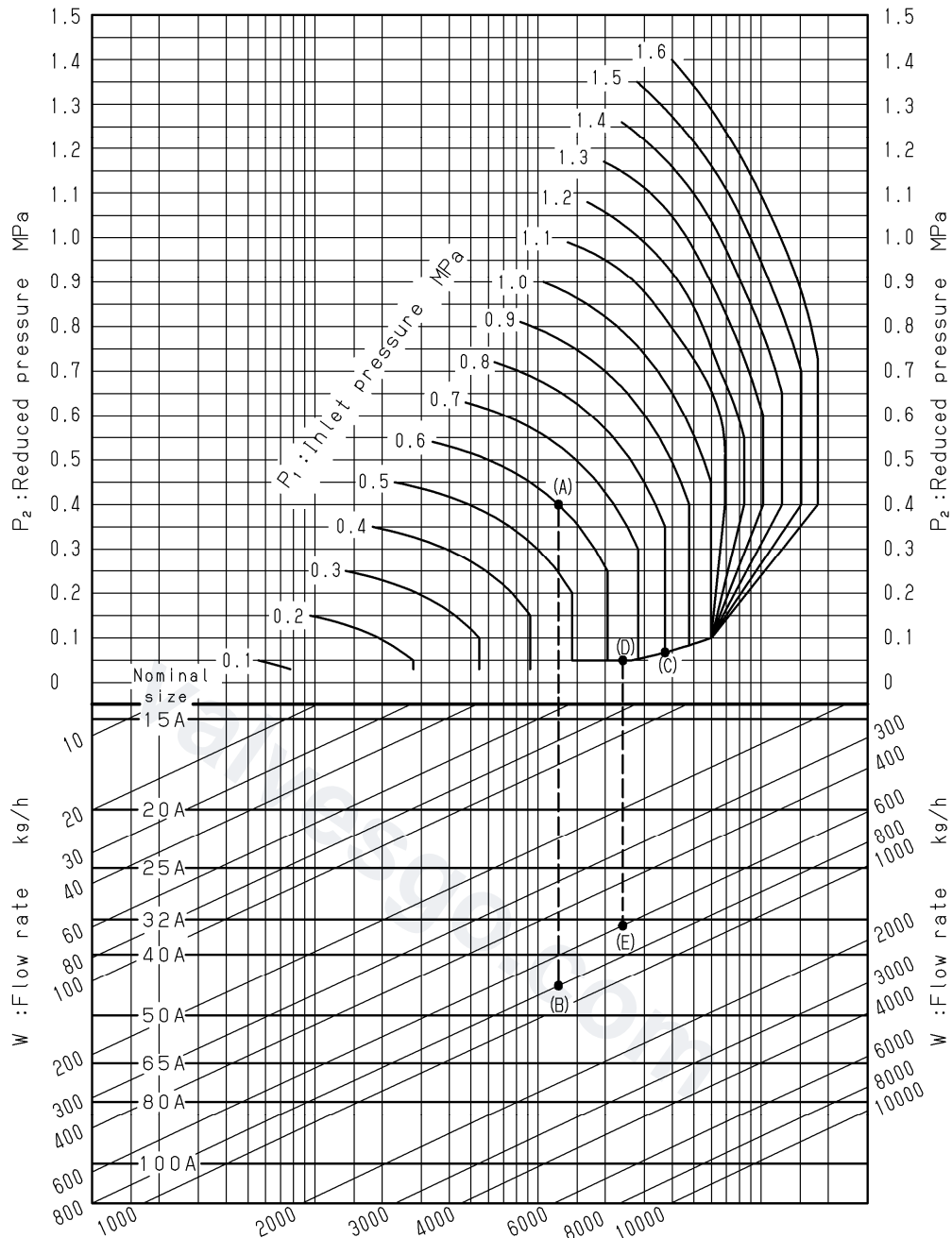

[Ex.1]

For example, take a pressure reducing valve whose inlet pressure (P_1) is 0.6 MPa, reduced pressure (P_2) is 0.4 MPa, flow rate 800 kg/h. First, find the point of intersection (A) of inlet pressure 0.6 MPa and reduced pressure 0.4 MPa. Vertically proceed from point (A) to come across the flow rate 800 kg/h, and regard this point as (B). Point (B) is between nominal sizes 40A and 50A. Select the larger nominal size 50A.

[Ex.2]

For example, take a pressure reducing valve whose inlet pressure (P_1) is 0.8 MPa, reduced pressure (P_2) is 0.05 MPa, flow rate 600 kg/h. First, find the point of intersection (C) of inlet pressure 0.8 MPa and the diagonal line. Move leftward down the diagonal line to intersection point (D) where the diagonals line intersect with the reduced pressure 0.05 MPa. Vertically proceed from point (D) to come across the flow rate 600 kg/h, and regard this point as (E). Point (E) is between nominal sizes 32A and 40A. Select the larger nominal size 40A.

5.5 Nominal size selection calculation formula

The appropriate nominal size can be calculated by obtaining the Cv value for the operating conditions in question, as shown below.

- Cv value calculation formula

$$P_2 > \frac{P_1}{2}$$

$$C_v = \frac{Wk}{138\sqrt{\Delta P(P_1 + P_2)}}$$

$$P_2 \leq \frac{P_1}{2}$$

$$C_v = \frac{Wk}{120P_1}$$

W: Max. steam flow rate [kg/h]

P₁: Inlet pressure [MPa · A]

P₂: Reduced pressure [MPa · A]

ΔP: P₁ - P₂ [MPa]

k: 1 + 0.0013 × {super-heated steam temp.[°C] - saturated steam temp.[°C]}

- Rated Cv value table (When Cv correction coefficient is C=1)

Nominal size	15A	20A	25A	32A	40A	50A	65A	80A	100A
Rated Cv value	1	2.3	4	6.5	9	16	25	36	64

※Correction of rated Cv value

If the inlet pressure exceeds 0.7 MPa, and the pressure reducing is 0.4 MPa or less, find the appropriate correction coefficient C using chart below, and multiply the rated Cv value, and obtain the corrected Cv value.

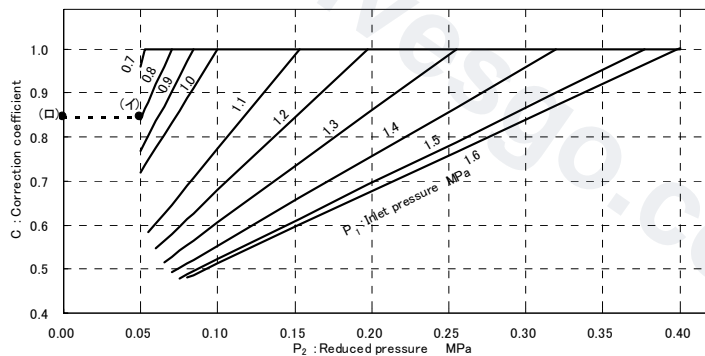

[Ex.]

Take a pressure reducing valve whose inlet pressure is 0.8 MPa, reduced pressure is 0.05 MPa. Find the inlet and reduced pressure intersection point (A) at the left chart, then draw a horizontal line in the leftward direction to point (B) which indicates a correction coefficient of 0.85. For a nominal size of 25A, the corrected Cv value would be calculated as follows:

4(rated Cv value) × 0.85(correction coefficient) = 3.4

6. Installation

6.1 Example of piping

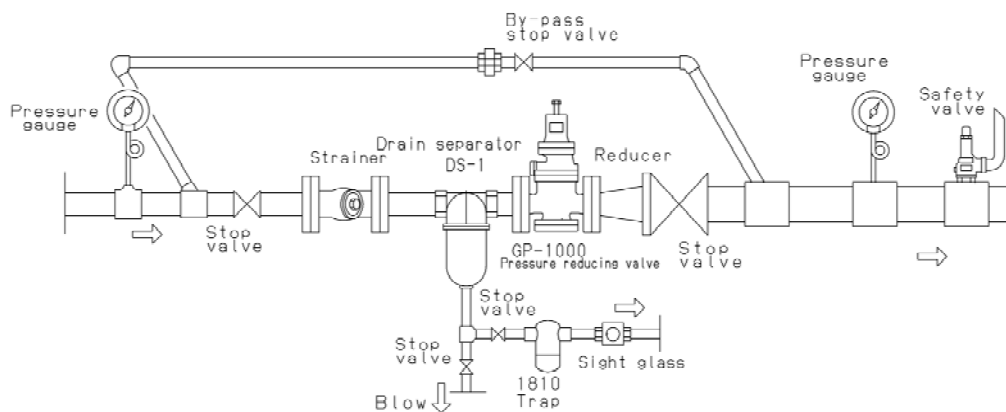

6.2 Precautions during installation

⚠ Warning

- (1) Because of heavy weight, hold the valve with lifting equipment while piping. Refer to “**3. Dimensions and weights**” table for the valve weight.
 - ※Failure to do so may result in injury due to dropping the valve.
- (2) In case installing safety valve as safety device at outlet side, joint relief pipe at outlet of safety valve and guide it to safety place where steam can relief out.
 - ※Failure to do so may result in burns.

⚠ Caution

- (1) Do not disassemble the valve unreasonably.
 - ※Disassembling the valve at your discretion may affect the original performance.
- (2) Remove foreign matter and scales from the lines before connecting the valve.
 - ※Failure to do so may prevent the valve from functioning correctly.
- (3) Install a strainer (Recommendation: 80-100mesh or equivalent) at the valve inlet side.
 - ※Failure to do so may hamper correct pressure control, which affects the original performance.
- (4) Install a safety valve at the valve outlet sides as safety device for equipment.
 - ※Failure to do so prevents problem identification, resulting in equipment damage.
- (5) Install a pressure gauge at both the inlet and outlet sides of the valve.
 - ※Failure to do so may hamper correct pressure adjustment.
- (6) Install a steam trap to the inlet sides of the valve to prevent drainage problems.
 - ※Failure to do so may result in drainage problem, affecting the original performance.
- (7) When installing quick open and close valves, such as a solenoid valve, install it at inlet side as much as possible, and secure at least 3 m from the valve.
 - ※Failure to do so may result in malfunction or drastically shortened service life.
- (8) When pressure reducing in two stages, secure at least 3 m between the valves.
 - ※Failure to do so may result in malfunction, affecting the original performance.
- (9) Install the valve in proper direction of the fluid flow.
 - ※Failure to do so may affect the original performance.
- (10) Do not apply excessive load, torque or vibration to the valve.
 - ※Doing so may result in malfunction or drastically shortened service life.

- (1) Install the valve perpendicularly to horizontal lines.
- (2) Provide the by-pass line. (See 6.1 Example of piping)
- (3) When the pressure-reducing ratio is large, install a reducer to keep the flow velocity in the pipe below 30 m/s or less.
- (4) Provide space on the top and bottom of the valve so that the valve can be easily disassembled and inspected. (See Fig.1)

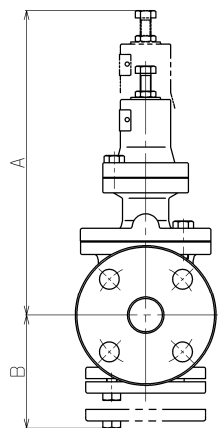

Fig.1

Nominal size	(mm)	
	A	B
15A	315	125
20A		135
25A		
32A	335	155
40A		345
50A	190	
65A		
80A	375	225
100A	395	265

7. Operating Procedure

7.1 Precautions during operation

Warning

- (1) Do not touch the valve directly with bare hands.
※Doing so may result in burns.
- (2) Before flow the steam in pipe line, make sure steam can flow without any dangerous at the end of pipe line and pipe line is connected tightly.
※In case steam blow off, it may result in burns.

Caution

- (1) Close the stop valves before and after the pressure reducing valve, and remove all foreign matter and scales via the by-pass line before operation. And, open each stop valve slowly.
※Failure to do so may prevent the valve from functioning correctly. And, It may cause hunting, water hammer, etc., resulting in damage to the valve and other equipment when the stop valve is opened quickly.
- (2) Secondary pressure at by-pass line must be lower than set pressure.
※Safety valve blows in case secondary pressure at by-pass line becomes higher than set pressure.
- (3) When adjusting pressure, slowly turn the adjusting screw
※Incorrect adjustment may cause hunting, water hammer, etc., resulting in damage to the valve and other equipment.
- (4) Remove condensate completely from the line, and close the stop valves before and after the valve when not using it for long periods of times.
※Rust generated in the valves and lines may cause malfunction.
- (5) For the model with handle, be sure to operate the handle manually and turn it while pushing down. At this time, do not turn with too much torque or do not turn excessively.
※Rust generated in the valves and lines may cause malfunction.

7.2 Adjustment procedures

Follow the steps below, and slowly turn the adjusting screw to set pressure. Incorrect adjustment may cause hunting, water hammer, etc., resulting in damage to the valve and other equipment.

- (1) Close the stop valve at inlet and outlet side of the pressure reducing valve, and taking sufficient time not to blow the safety valve, blow off the fluid to remove foreign matter via the by-pass line. After blowing, close the by-pass line stop valve.
- (2) Slowly open the stop valve at the inlet side of the pressure reducing valve, and adjust the travel of the stop valve at the outlet side of the pressure reducing valve so that a little fluid flows.
- (3) Loosen the lock nut, and slowly turn the adjusting screw to achieve the desired pressure (clockwise to increase, counterclockwise to reduce) while observing the pressure gauge on the outlet side. While adjusting the pressure, push down and turn the handle slowly because the handle is locked in normal position and look at the secondary side of pressure gauge closely. (Secondary pressure rises by turning the handle in clockwise and descends in counterclockwise).
- (4) Slowly open the stop valve at the outlet of the pressure reducing valve, and readjust the desired pressure.
- (5) After adjustment, tighten the lock nut. For the model with handle, handle is pulled up and locked by releasing hold. If it is not locked, turn the handle to left and right then release it.

8. Maintenance Procedure

8.1 Troubleshooting

Problem	Cause	Solution
Pressure does not reach the desired value.	<ol style="list-style-type: none"> 1. Incorrect pressure is being used. 2. Strainer [28] is clogged. 3. Foreign matter exists between piston [14] and cylinder [15]. 4. Piston ring [16] is damaged. 5. Nominal size is too small for the specifications. 6. Pressure is not adjusted correctly. 7. Strainer installed before pressure reducing valve is clogged. 8. Pressure gauge is faulty. 	<ol style="list-style-type: none"> 1. Correct the pressure. 2. Disassemble and clean the strainer. 3. Disassemble and remove the foreign matter. When any scratches are identified, polish them away using a paper. Change the parts if scratches still exist after polishing. 4. Replace the piston ring. 5. Change the nominal size appropriately. 6. Observe the adjustment procedures and readjust pressure. 7. Disassemble and clean it. 8. Replace it.
Reduced pressure raises above than the specified value.	<ol style="list-style-type: none"> 1. Foreign matter exists between main valve [11] and main valve seat [12], or scratches exist. 2. Foreign matter exists between pilot valve [19] and pilot valve seat [20], or scratches exist. 3. Foreign matter exists between piston [14] and cylinder [15]. 4. Trap is not provided for dead-end line. 5. By-pass valve is leaking. 6. Diaphragm [5] is damaged. 	<ol style="list-style-type: none"> 1. Disassemble and remove the foreign matter. When any scratches are identified, lap the main valve and main valve seat. Change the parts if scratches still exist after lapping. 2. Disassemble the pilot valve assembly, and clean or replace it. 3. Disassemble and remove the foreign matter. When any scratches are identified, polish them away using a paper. Change the parts if scratches still exist after polishing. 4. Install a trap. 5. Repair or replace it. 6. Replace the diaphragm.
Abnormal noise is heard.	<ol style="list-style-type: none"> 1. Nominal size is too large for the specifications. 2. Pressure reducing ratio is too large. 3. Drainage problem is caused. 4. An abrupt OPEN/CLOSE valve is located too close to the pressure reducing valve. 5. Outlet pipe is too small. 	<ol style="list-style-type: none"> 1. Change the nominal size appropriately. 2. Reduce pressure in two stages. 3. Install a trap. 4. Allow as much as possible between the valves. 5. Select a pipe size that will produce a flow velocity of 30m/s or less.

- Foreign matter and scales in a pipe may cause most of problems of pressure reducing valve. Be careful sufficiently to foreign matter in a pipe.
- Phenomenon alike valve trouble may happen by fault of pressure gauge, fluid leakage from by-pass valve, forgetting to close the by-pass valve, clogging strainer, and etc. First, check the said particulars before above troubleshooting.
- Consult factory when cannot make a judgement whether parts need replacement or not.

8.2 Precautions during maintenance and inspection

Warning

- (1) Completely discharge internal pressure from the valves, lines, and equipment, and cool the valve down to a level where you can touch it with bare hands before disassembly and inspection.
- ※ Failure to do so may result in injury or burns due to residual pressure or spillage around the valve.

Caution

- (1) In order to maintain original performance and function, examine daily and personal inspection. And, periodical inspection must be examined according to the regulations of every kind.
- ※ For general users, request to specialized dealer or manufacture.
- (2) Pressure reducing valve shall be disassembled and inspected by qualified person or manufacture.
- ※ Request the treatment to specialized dealer or manufacture in case of any problems.
- (3) While disassembly, drain flow out from the valve, so catch it by container. And release steam completely before disassembling.
- ※ In case of no container for drain, it makes dirty surrounding the valve.
- (4) Close the stop valves before and after the pressure reducing valve, and remove all foreign matter and scales via the by-pass line before operation.
- ※ Failure to do so may prevent the valve from functioning correctly.
- (5) When adjusting pressure, slowly turn the adjusting screw.
- ※ Incorrect adjustment may cause hunting, water hammer, etc., resulting in damage to the valve and other equipment.
- (6) Remove condensate completely from the line, and close the stop valves before and after the valve when not using it for long periods of times.
- ※ Rust generated in the valves and lines may cause malfunction.
- (7) In case of no operation for a long period of time, perform operating exam before start operation again.
- ※ Request the treatment to specialized dealer or manufacture in case of any problems.

8.3 Disassembly

Be sure that the stop valves at inlet and outlet side of pressure reducing valve is closed and all internal pressure and condensate have discharged before disassembling the valve.

(1) Pilot valve

1. Loosen the lock nut [10] and turn the adjusting screw [9] to release the spring [8] (no compression). For the model with handle, turn the handle in counterclockwise while pushing down in order to change the adjusting spring into free position.
2. Remove the bolt [33] of the spring chamber [4]. Remove the spring chamber, spring, top spring plate [6], bottom spring plate [7], and diaphragm [5]. For the model with handle, remove the handle and spring chamber by one since they cannot disassemble.
3. Remove the pilot valve assembly [19], [20] using a ring spanner or socket wrench (nominal size 22)

(2) Piston

1. Remove the bolt [34] of the top cover [2] and the top cover. Pick up the spindle [18], and remove the piston ring [16] and the inner ring [17].

(3) Main valve

1. Remove the bolt [35] of the bottom cover [3]. Remove the bottom cover, main valve spring [13], and main valve [11].

8.4 Precautions during disassembly

Caution

- (1) Check that there is no damage and scratches on the main valve, main valve seat, pilot valve, and pilot valve seat.
 - ※Any scratches at sealing surface lead to increase in secondary pressure. When any scratches are identified at main valve and seat, polish them away. And, change the parts if scratches still exist after polishing. Also, in case any scratches are identified at pilot valve and pilot valve seat, change into pilot valve assembly.
- (2) Move the sliding section (pilot valve, piston, etc.) two to three times and confirm they move smoothly.
 - ※If the sliding parts do not move correctly, it may cause failure problems. (Working not correctly).
- (3) Replace gaskets with new ones when reassembling.
 - ※If the gasket is used for a long time, it may cause steam leakage problem.
- (4) Assemble in the reverse order of Disassembly. And tighten the bolts evenly.
 - ※Assemble the valve due to the order. Failure to do so may lead to not assemble correctly. And if the hexagon bolts are not screwed correctly, it may cause steam leakage problem.

valvesgo.com

8.5 Exploded drawing

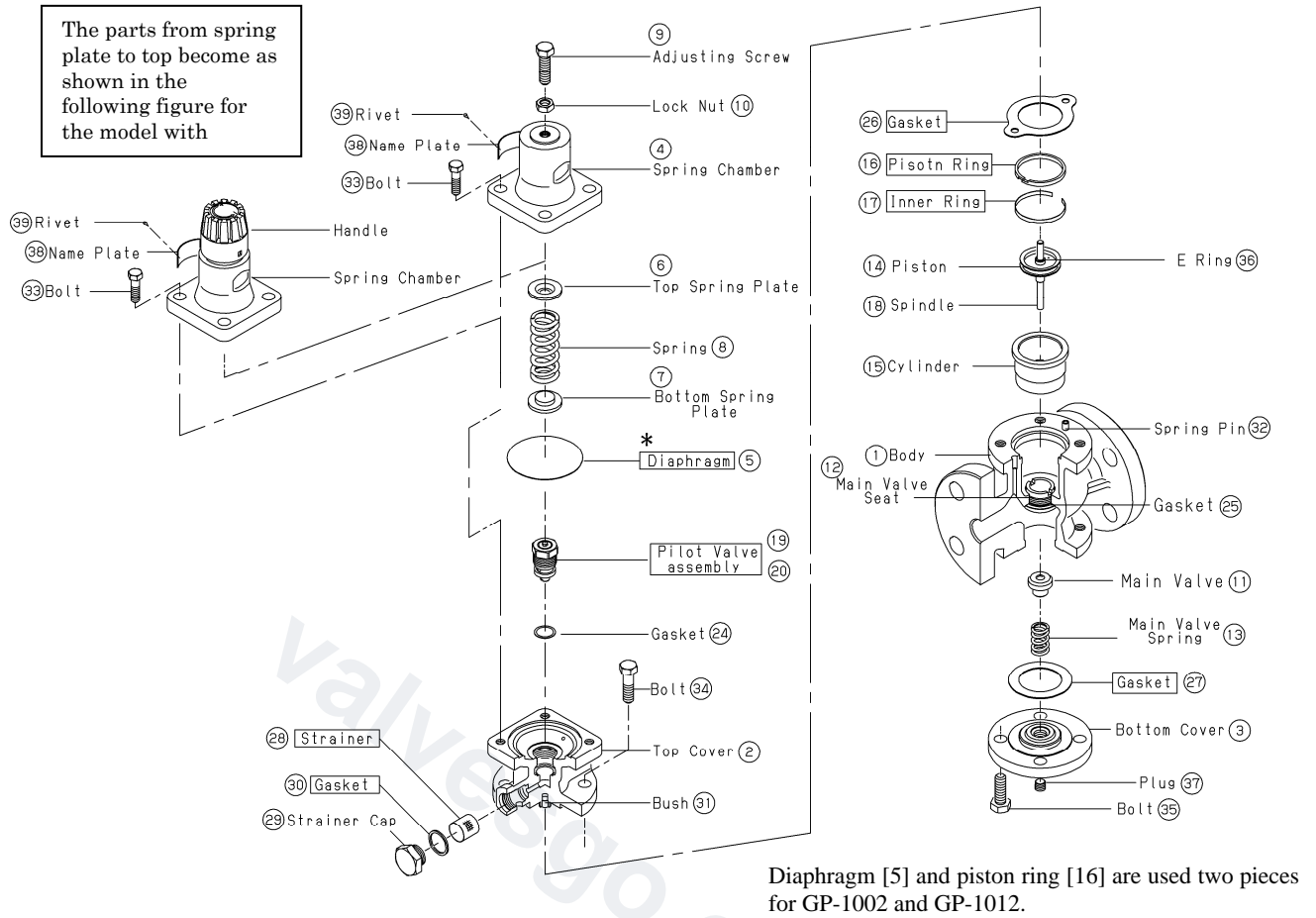

Parts with in the flame are consumable. Please contact us for purchase of these consumable parts.

No.	Name of parts	Replace period
5	Diaphragm	2 years
16	Piston ring	3 years
17	Inner ring	3 years
19•20	Pilot valve assembly	5 years
24	Gasket	5 years
26•27	Gasket	2 years
28	Strainer	5 years
30	Gasket	2 years

Note (*): Apply a liquid sealant for heat and steam resistant (Recommendation: SOLVEST 110) to the sealing surface of the diaphragm bottom and the top cover.