

# GP-1000T

- Direct type  Pilot type  Piston  Diaphragm
- Bellows  Internal sensing  External sensing  Stainless steel
- With handle  Built-in strainer  Low pressure  Remote
- Valve leakage 0  Nylon



GP-1000T



GP-1010T



GP-1200T

## ■Features

1. Far superior to conventional pressure reducing valve in workability and durability.
2. Free of valve seat leakage. Improved workability as a result of refinement of sliding parts.
3. Simple and robust internal structure.

## ■Specifications

Model	GP-1000T	GP-1010T	GP-1200T	GP-1210T
Application	Air, Other non-dangerous fluids			
Inlet pressure	0.1-1.0 MPa			
Reduced pressure	0.05-0.9 MPa			
	90% or less of inlet pressure (gauge pressure)			
Minimum differential pressure	0.05 MPa			
Maximum pressure reduction ratio	20:1			
Application temperature	5-80°C			
Valve seat leakage	None			
Material	Body	Ductile cast iron		
	Valve	Brass (NBR incorporated)		
	Valve seat	Stainless steel		
	Piston, cylinder	Brass or bronze		
	Diaphragm	Stainless steel		
Connection	JIS 10K FF flanged	JIS Rc screwed	JIS 10K FF flanged	JIS Rc screwed

· Available with stainless steel made trim parts (piston, cylinder and valve) as GP-□□□□TS.

## ■ Dimensions (mm) and Weights (kg)

### · GP-1000T · 1200T

Nominal size	L	H <sub>1</sub>	H	Weight
15A	150	64	285 (220)	8.0
20A	155	64	285 (220)	8.5
25A	160	67	300 (235)	10.0
32A	190	82	323 (258)	14.0
40A	190	82	323 (258)	14.5
50A	220	93	347 (282)	20.0
65A	245	100	357 (292)	30.0
80A	290	122	404 (339)	35.0
100A	330	144	450 (385)	52.5

\* The above values in parentheses are the dimensions of the GP-1200T.

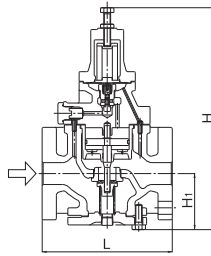

GP-1000T

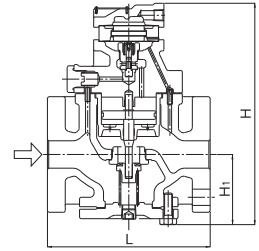

GP-1200T

### · GP-1010T · 1210T

Nominal size	d	L	H <sub>1</sub>	H	Weight
15A	Rc 1/2	150	64	285 (220)	7.0
20A	Rc 3/4	155	64	285 (220)	7.0
25A	Rc 1	160	67	300 (235)	8.5
32A	Rc 1-1/4	190	82	323 (258)	12.0
40A	Rc 1-1/2	190	82	323 (258)	12.5
50A	Rc 2	220	93	347 (282)	18.0

\* The above values in parentheses are the dimensions of the GP-1210T.

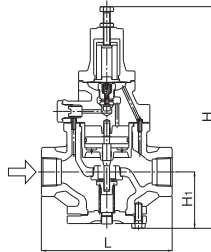

GP-1010T

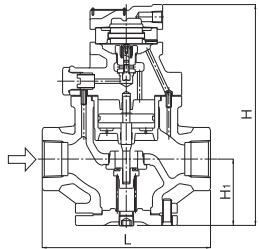

GP-1210T

### · GP-1000TSS · 1000TAS

Nominal size	L	H <sub>1</sub>	H	Weight
15A	150	67	288 (298)	8.3 ( 8.5)
20A	155	67	288 (298)	8.8 ( 9.0)
25A	160	70	303 (313)	10.5 (10.7)
32A	190	85	326 (336)	14.8 (15.0)
40A	190	85	326 (336)	15.3 (15.5)
50A	220	96	350 (360)	20.8 (21.0)

\* The above values in parentheses are the dimensions and weights of the GP-1000TAS.

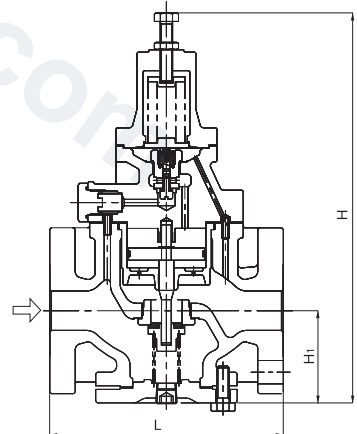
GP-1000TSS  
GP-1000TAS

**■ Loading Air Pressure-set Pressure Chart**

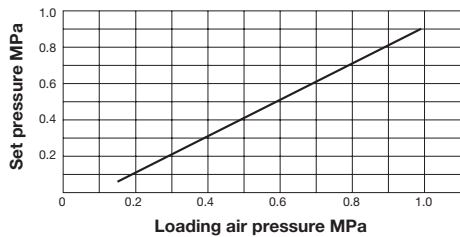

Basically, the set pressure to the loading air pressure is as shown in the chart on the left. The set pressure is slightly different depending on the conditions. In this case, adjust the loading air pressure.

**Specifications Selection Chart**

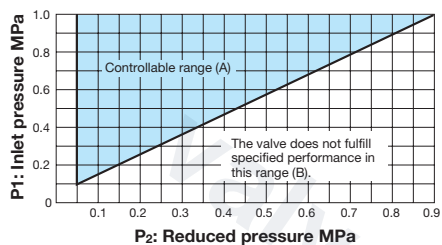

Find the intersection point of the inlet and reduced pressures. If the intersection point is within range (A), the pressures are controllable. The valve does not fulfill specified performance if the intersection point lies in range (B).

**Table of Corrected Cv Values**

Please refer to **■**-14 for Cv value.

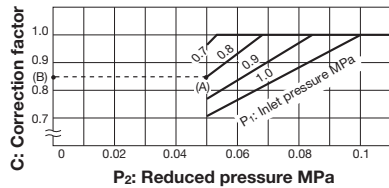

If the inlet pressure exceeds 0.7 MPa, and the pressure reducing ratio exceeds 10:1, find the appropriate correction coefficient C using chart above, and multiply the rated Cv value, and obtain the corrected Cv value.

**Example**

Take a pressure reducing valve whose inlet pressure is 0.8 MPa, the reduced pressure is 0.05 MPa. Find the inlet and reduced pressure intersection point (A) at the above chart, then draw a horizontal line in the leftward direction to point (B) which indicates a correction coefficient of 0.85. For a nominal size of 25A, the corrected Cv value would be calculated as follows:  
 $4 \text{ (rated Cv value)} \times 0.85 \text{ (correction coefficient)} = 3.4$

**■ GP-1000T Series Selection Chart**

**Flow Characteristic Chart**

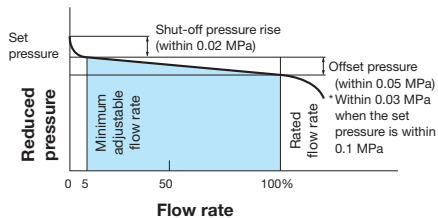

**Pressure Characteristic Chart**

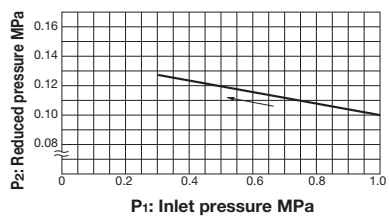

This chart shows variation in reduced pressure when the inlet pressure of 1.0 MPa is changed between 0.3 MPa and 1.0 MPa while the reduced pressure is set at 0.1 MPa.

## Nominal Sizes Selection Chart (Fluid: 20°C Air)

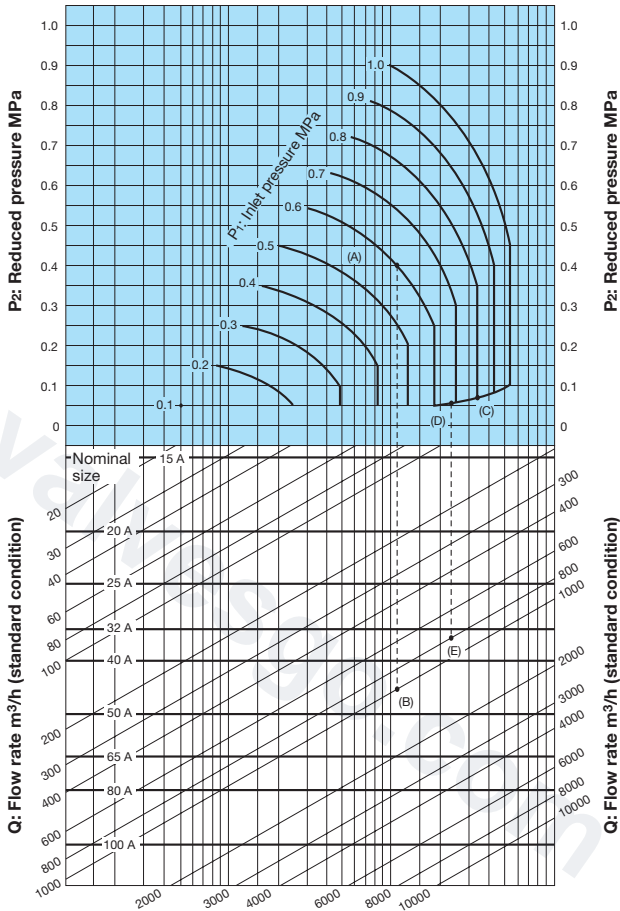

### [Example 1]

When selecting the nominal size of a pressure reducing valve whose inlet pressure ( $P_1$ ), reduced pressure ( $P_2$ ), and air flow rate are 0.6 MPa, 0.4 MPa, and 1,000  $m^3/h$  (standard condition), respectively, first find intersection point (A) of the inlet pressure of 0.6 MPa and the reduced pressure of 0.4 MPa. Trace down vertically from this intersection point to find intersection point (B) with the flow rate of 1,000  $m^3/h$  (standard condition). Since intersection point (B) lies between nominal sizes 40A and 50A, select the larger one, 50A.

### [Example 2]

When selecting the nominal size of a pressure reducing valve whose inlet pressure ( $P_1$ ), reduced pressure ( $P_2$ ), and air flow rate are 0.8 MPa, 0.05 MPa, and 800  $m^3/h$  (standard condition), respectively, first find intersection point (C) of the inlet pressure of 0.8 MPa and the diagonal line. Trace down to the left from the diagonal line to find intersection point (D) with the reduced pressure of 0.05 MPa. Trace down vertically from intersection point (D) to find intersection point (E) with the flow rate of 800  $m^3/h$  (standard condition). Since intersection point (E) lies between nominal sizes 32A and 40A, select the larger one, 40A.

\* Set the safety factor at 80 to 90%.