

GPK-2001,2003

Direct type	Pilot type	Piston	Diaphragm
Bellows	Internal sensing	External sensing	Stainless steel
With handle	Built-in strainer	Low pressure	Remote
Valve leakage 0	Nylon		

■Features

1. Superior to piston type valve in capacity and performance. Very effective in controlling inlet pressure and flow rate fluctuations.
2. Spherical main valve offers great sealability and great reduction of valve seat leakage (compliant with ANSI Class IV).
3. Remote control makes pressure adjustment easy, and the pressure setting is wide.
4. The GPK-2001 and GPK-2003 can be selected according to the loading air pressure.



GPK-2001



GPK-2003

■Specifications

Model		GPK-2001	GPK-2003
Application		Steam	
Reduced pressure sensing method		External sensing *	
Inlet pressure	JIS Rc JIS 20K RF	0.1-2.0 MPa	0.25-2.0 MPa
	JIS 10K FF	0.1-1.0 MPa	0.25-1.0 MPa
Reduced pressure		0.05-0.9 MPa (0.85 MPa for JIS 10K)	0.2-1.4 MPa (0.85 MPa for JIS 10K)
Loading air pressure		85% or less of inlet pressure (gauge pressure)	
Minimum differential pressure		Refer to the loading air pressure-set pressure chart.	
Maximum differential pressure		0.05 MPa	
Maximum pressure reduction ratio		20:1	10:1
Maximum temperature		220°C	
Valve seat leakage		0.01% or less of rated flow	
Material	Body	Ductile cast iron	
	Main valve	Stainless steel	
	Valve seat	Stainless steel	
	Pilot valve	Stainless steel	
	Pilot valve seat	Stainless steel	
	Diaphragm	Stainless steel	
Reduced pressure detection pipe		Copper pipe ϕ 8-2 m	
Connection		JIS Rc screwed JIS 20K RF and 10K FF flanged	

* External sensing is standard. When installing the pressure reducing valve, be sure to connect the provided sensing pipe and joint. Unless the sensing pipe is connected, the valve will not operate.
(Available with internal sensing type in different specifications. Note that the Cv value of internal sensing type is lower than that of external sensing type.)

· Available with ASME or EN flanged.

■For Pneumatic Circuit Operation

Please refer to P.1-18.

■ Dimensions (mm) and Weights (kg)

· GPK-2001screwed type

Nominal size	d	L	H ₁	H	A	Weight
15A	Rc 1/2	150	170	335	200	14.0
20A	Rc 3/4	150	170	335	200	14.0
25A	Rc 1	160	175	341	226	18.5
32A	Rc 1-1/4	180	192	371	226	21.5
40A	Rc 1-1/2	180	192	371	226	21.5
50A	Rc 2	230	216	435	276	33.0

* Available with NPT connection.

· GPK-2003 screwed type

Nominal size	d	L	H ₁	H	A	Weight
15A	Rc 1/2	150	170	353	200	17.5
20A	Rc 3/4	150	170	353	200	17.5
25A	Rc 1	160	175	359	226	22.0
32A	Rc 1-1/4	180	192	389	226	25.0
40A	Rc 1-1/2	180	192	389	226	25.0
50A	Rc 2	230	216	453	276	36.5

* Available with NPT connection.

· GPK-2001 flanged type (JIS 20K RF)

Nominal size	L	H ₁	H	A	Weight
15A	146 (142)	170	335	200	15.5 (15.3)
20A	146 (142)	170	335	200	16.0 (15.8)
25A	156 (152)	175	341	226	21.0 (20.6)
32A	176 (172)	192	371	226	24.0 (23.4)
40A	196 (192)	192	371	226	24.5 (24.1)
50A	222 (218)	216	435	276	36.0 (35.8)
65A	282 (278)	251	489	352	64.5 (64.2)
80A	302 (294)	264	512	352	71.5 (69.3)
100A	342 (330)	321	595	401	111.0 (107.4)

* The above values in parentheses are the dimensions and weights of JIS 10K FF flanged.

· Please contact us for other specifications.

· GPK-2003 flanged type (JIS 20K RF)

Nominal size	L	H ₁	H	A	Weight
15A	146 (142)	170	353	200	19.0 (18.8)
20A	146 (142)	170	353	200	19.5 (19.3)
25A	156 (152)	175	359	226	24.5 (24.1)
32A	176 (172)	192	389	226	27.5 (27.1)
40A	196 (192)	192	389	226	28.0 (27.6)
50A	222 (218)	216	453	276	39.5 (39.3)
65A	282 (278)	251	507	352	68.0 (67.7)
80A	302 (294)	264	530	352	75.0 (72.8)
100A	342 (330)	321	613	401	114.5 (113.9)

* The above values in parentheses are the dimensions and weights of JIS 10K FF flanged.

· Please contact us for other specifications.

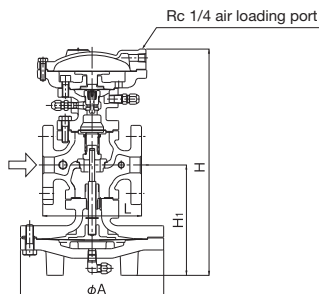
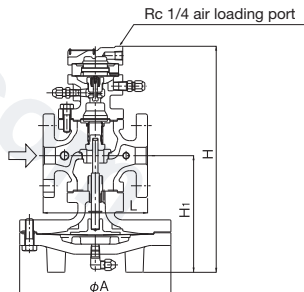
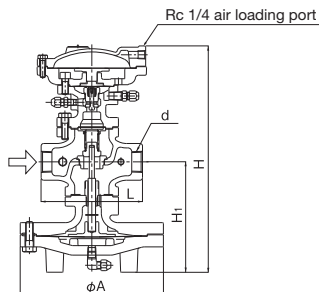
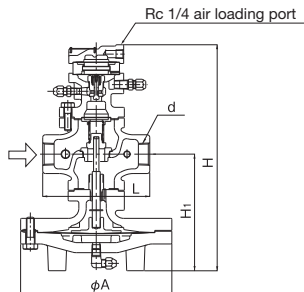

■ Dimensions (mm) and Weights (kg)

· Screwed type

Nominal size	d	L	H ₁	H	A	Weight
15A	Rc 1/2	150	74	244	200	12.4
20A	Rc 3/4	150	74	244	200	12.4
25A	Rc 1	160	76	251	226	16.4
32A	Rc 1-1/4	180	90	282	226	19.9
40A	Rc 1-1/2	180	90	282	226	19.9
50A	Rc 2	230	103	319	276	30.5

* Available with NPT connection.

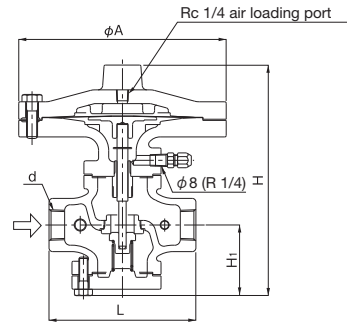

Screwed type

· Flanged type

Nominal size	L	H ₁	H	A	Weight
15A	146 (142)	74	244	200	13.9 (13.7)
20A	146 (142)	74	244	200	14.4 (14.2)
25A	156 (152)	76	251	226	19.2 (18.8)
32A	176 (172)	90	282	226	22.4 (22.0)
40A	196 (192)	90	282	226	22.9 (22.5)
50A	222 (218)	103	319	276	33.5 (33.5)
65A	282 (278)	122	373	352	61.8 (61.5)
80A	302 (294)	135	399	352	69.1 (66.9)
100A	342 (330)	167	488	401	108.6 (105.0)

* The above values in parentheses are the dimensions and weights of JIS 10K FF flanged.

· Please contact us about other specifications.

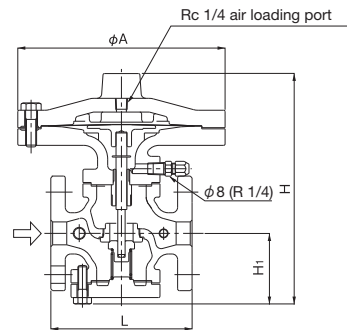

Flanged type

Specifications Selection Chart

· GP-2000, GPK-2001 · 2003

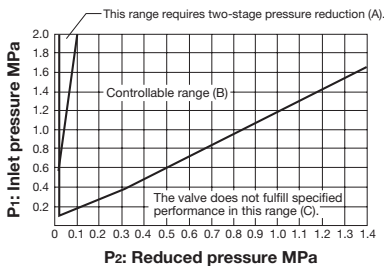

· GDK-2000

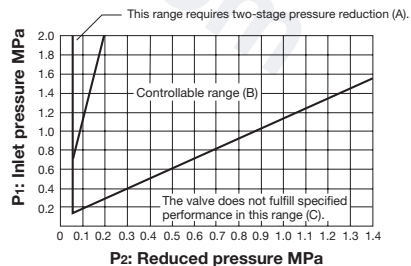

Please refer to the above selection chart to select the most appropriate pressure reducing valve. Find the point of intersection of inlet pressure (P₁) and reduced pressure (P₂). When the point of intersection is within range (A), reduce pressure in two stages. When within range (B), controllable range. When within range (C), maximum performance cannot be obtained. When reducing pressure in two stages, maximize the distance between the valves (at least 3 m).

Nominal Sizes Selection Chart for GP-2000 Series (For Steam/External Sensing)

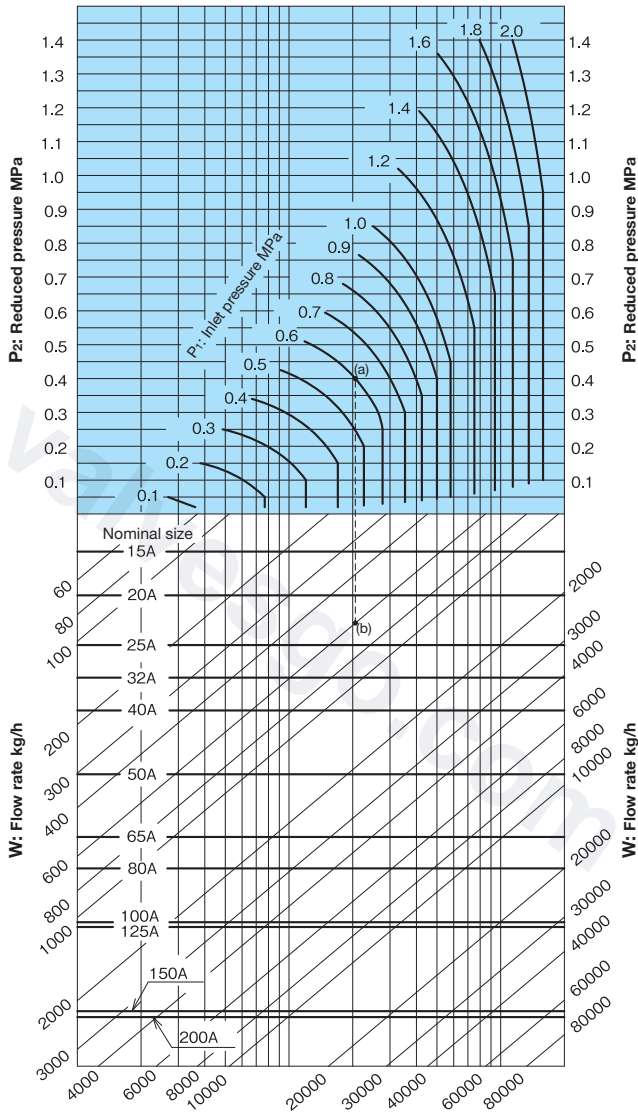

[Example]

When selecting the nominal size of a pressure reducing valve whose inlet pressure (P₁), reduced pressure (P₂), and flow rate are 0.6 MPa, 0.4 MPa, and 600 kg/h, respectively, first find intersection point (a) of the inlet pressure of 0.6 MPa and the reduced pressure of 0.4 MPa. Trace down vertically from this intersection point to find intersection point (b) with the flow rate of 600 kg/h. Since intersection point (b) lies between nominal sizes 20A and 25A, select the larger one, 25A.

- Set the safety factor at 80 to 90%.

Flow Characteristic Chart

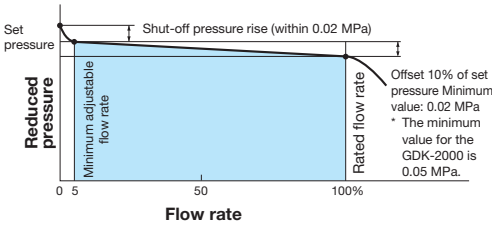

When selecting a nominal size, set the flow rate at 80 to 90% of the rated flow rate, allowing for the pressure loss and heat loss of the stop valve, strainer, etc. to be used before or after the pressure reducing valve. To enable the pressure reducing valve to show a maximum flow characteristic, do not select a small piping diameter, as a countermeasure against the effect of piping resistance. Select a nominal size based on the nominal sizes selection chart.

Pressure Characteristic Chart

GP-2000, GPK-2001 · 2003

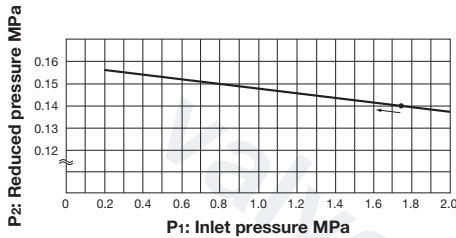

This chart shows variation in reduced pressure when the inlet pressure of 1.75 MPa is changed between 0.2 MPa and 2.0 MPa while the reduced pressure is set at 0.14 MPa.

GDK-2000

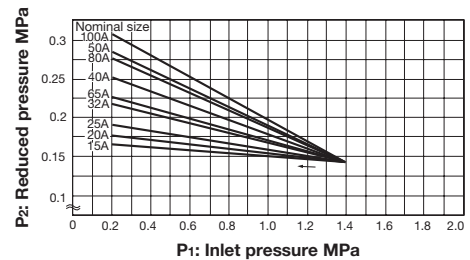

This chart shows variation in reduced pressure when the inlet pressure of 1.4 MPa is changed between 0.2 MPa and 1.4 MPa while the reduced pressure is set at 0.14 MPa.

Loading Air Pressure-set Pressure Chart

GP-2000, GPK-2001 · 2003

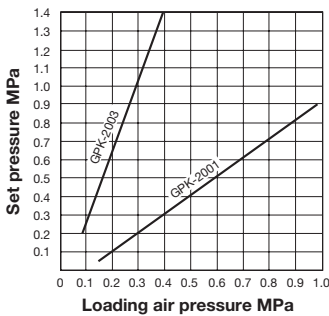

Basically, the set pressure to the loading air pressure is as shown in the chart above. The set pressure is slightly different depending on the working conditions. For the actual use, adjust loading air pressure suitable for the necessary set pressure.

GDK-2000

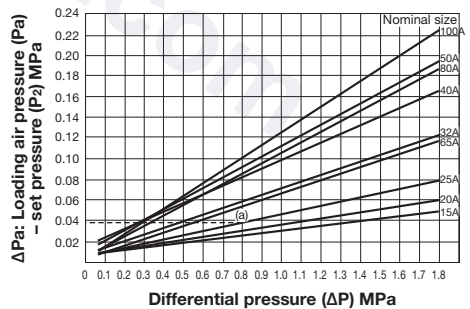

How to read the chart (GDK-2000)

When the nominal size is 25A, the inlet pressure (P_1) is 1.0 MPa, and the reduced pressure (P_2) is 0.2 MPa, the loading air pressure is calculated as follows: Trace up vertically from the differential pressure (ΔP) before and after the pressure reducing valve ($1.0 \text{ MPa} - 0.2 \text{ MPa} = 0.8 \text{ MPa}$) to find intersection point (a) with the nominal size of 25A. Calculate ΔPa [loading air pressure (P_a) - set pressure (P_2)] = 0.037 MPa by horizontally tracing to the left from intersection point (a). Thus, the loading air pressure is: (P_a) = $\Delta Pa + P_2 = 0.037 + 0.2 = 0.237 \text{ MPa}$.