

Model GPK-2001, GPK-2003
PRESSURE REDUCING VALVE
Installation & Operation Manual

Thank you very much for choosing the Yoshitake's product. To ensure the correct and safe use of the product, please read this manual before use. This manual shall be kept with care for future references.

-----The following safety symbols are used in this manual. -----

 **Warning**

This symbol indicates a potentially hazardous situation that, if not avoided, could result in death or serious injury.

 **Caution**

This symbol indicates a hazardous situation that, if not avoided, may result in minor or moderate injury. ("Caution" may also be used to indicate other unsafe practices or risks of property damage.)

Contents

1. Specifications	1~2
2. Dimensions and Weights	2~3
3. Operation	4~6
4. Nominal Size Selection Method	
4.1 Specifications selection chart	7
4.2 Safety valve setting pressure chart	7
4.3 Characteristics chart	8
4.4 Nominal size selection chart	9
4.5 Nominal size selection calculation formula	10
5. Installation	
5.1 Precautions for installation	11
5.2 Installing accessories	11
5.3 Piping before and after the pressure reducing valve	12
5.4 Example of piping	13
6. Operating Procedure	
7.1 Precautions for operation	14
7.2 Adjustment procedures	14
7. Maintenance Procedure	
8.1 Troubleshooting	15~16
8.2 Precautions for maintenance and inspection	16
8.3 Disassembly	16~17
8.4 Precautions during reassembly	17
8.5 Exploded drawing	18~19
Warranty Information	

YOSHITAKE 

1. Specifications

[Models]

Model	Nominal pressure	Connection	Nominal size	The ratio of control pressure to setting pressure
GPK-2001	2.0 MPa	Screwed	15 ~ 50A	1: 1
	1.0 MPa	Flanged	15 ~ 100A	
GPK-2003	2.0 MPa	Screwed	15 ~ 50A	1: 3.5
	1.0 MPa	Flanged	15 ~ 100A	

[Specifications]

Model	GPK-2001	GPK-2003
Reduced pressure sensing method (*1)	External sensing	
Connection	JIS Rc screwed, JIS 20K RF flanged, JIS 10K FF flanged	
Nominal size	15 ~ 50A (Screwed), 15 ~ 100A (Flanged)	
Fluid	Steam	
Inlet pressure	0.1 ~ 2.0 MPa (JIS Rc, JIS 20K) 0.1 ~ 1.0 MPa (JIS 10K)	0.25 ~ 2.0 MPa (JIS Rc, JIS 20K) 0.25 ~ 1.0 MPa (JIS 10K)
Reduced pressure	0.05 ~ 0.9 MPa (JIS Rc, JIS 20K) 0.05 ~ 0.85 MPa (JIS 10K)	0.2 ~ 1.4 MPa (JIS Rc, JIS 20K) 0.2 ~ 0.85 MPa (JIS 10K)
	85% or less of inlet pressure (gauge pressure)	
System air pressure	Refer to Standard "Loading pressure - Set pressure" chart line.	
Min. differential pressure	0.05 MPa	
Max. pressure reducing ratio	20: 1	10: 1
Max. temperature	220 °C	
Valve seat leakage	0.01% or less of rated flow	
Material	Body	Ductile Cast iron
	Main valve	Stainless steel
	Main valve seat	Stainless steel
	Pilot valve	Stainless steel
	Pilot valve seat	Stainless steel
	Diaphragm	Stainless steel

(*1) For reduced pressure sensing method, internal sensing method valves will be available upon request.

Caution

(1) Please collate with attached nameplate and specification of ordered model.
* Please consult factory in case they do not match each other.

[Standard "Loading Pressure - Set Pressure" chart Line]

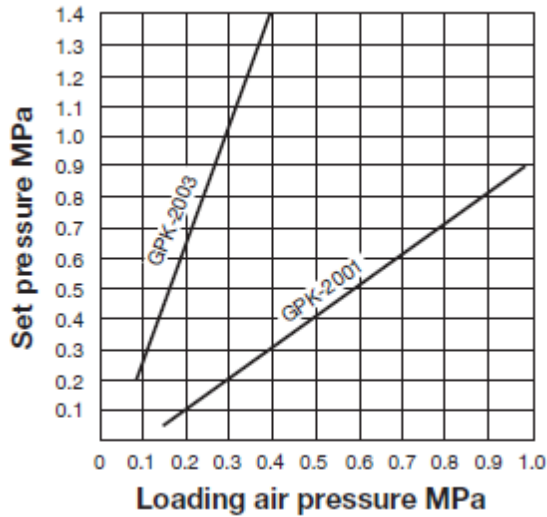

Basically, the set pressure to the loading air pressure is as shown in the chart above. The set pressure is slightly different depending on the working conditions. For the actual use, adjust loading air pressure suitable for the necessary set pressure.

2. Dimensions and Weights

[GPK-2001]

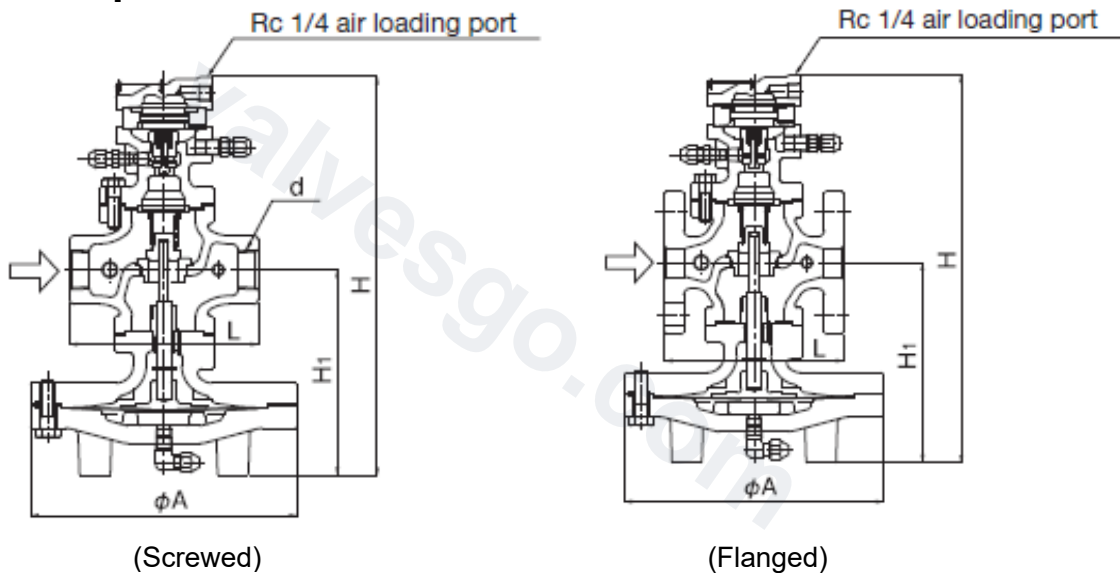

·The structure differs for nominal sizes 50A to 100A.

Nominal Size	Screw (JIS Rc)						Flanged (JIS 20K RF)				
	d	L	H	H ₁	A	Weight (kg)	L	H	H ₁	A	Weight (kg)
15A	Rc 1/2	150	335	170	200	14.0	146	335	170	200	15.5
20A	Rc 3/4	150	335	170	200	14.0	146	335	170	200	16.0
25A	Rc 1	160	341	175	226	18.5	156	341	175	226	21.0
32A	Rc 1-1/4	180	371	192	226	21.5	176	371	192	226	24.0
40A	Rc 1-1/2	180	371	192	226	21.5	196	371	192	226	24.5
50A	Rc 2	230	435	216	276	33.0	222	435	216	276	36.0
65A	-----	—	—	—	—	-----	282	489	251	352	64.5
80A	-----	—	—	—	—	-----	302	512	264	352	71.5
100A	-----	—	—	—	—	-----	342	595	321	401	111.0

* Different Length (L) and Weight values apply for JIS 10K FF.

* Other standard connections are available upon request.

[GPK-2003]

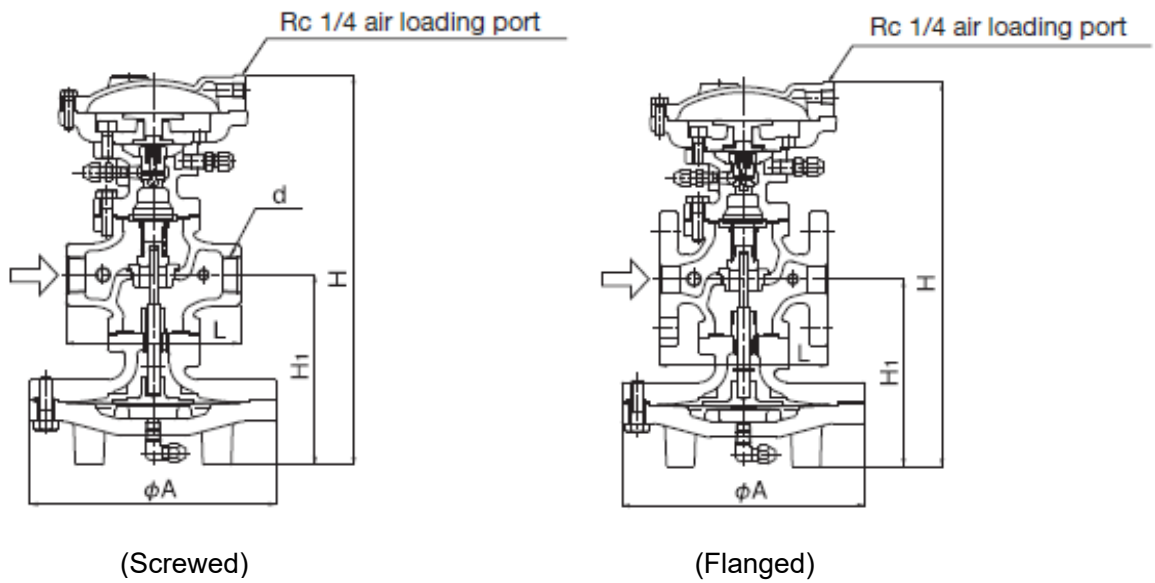

•The structure differs for nominal sizes 50A to 100A.

(mm)

Nominal Size	Screw (JIS Rc)						Flanged (JIS 20K RF)				
	d	L	H	H ₁	A	Weight (kg)	L	H	H ₁	A	Weight (kg)
15A	Rc 1/2	150	353	170	200	17.5	146	353	170	200	19.0
20A	Rc 3/4	150	353	170	200	17.5	146	353	170	200	19.5
25A	Rc 1	160	359	175	226	22.0	156	359	175	226	24.5
32A	Rc 1-1/4	180	389	192	226	25.0	176	389	192	226	27.5
40A	Rc 1-1/2	180	389	192	226	25.0	196	389	192	226	28.0
50A	Rc 2	230	453	216	276	36.5	222	453	216	276	39.5
65A	-----	—	—	—	—	-----	282	507	251	352	68.0
80A	-----	—	—	—	—	-----	302	530	264	352	75.0
100A	-----	—	—	—	—	-----	342	613	321	401	114.5

* Different Length (L) and Weight values apply for JIS 10K FF.

* Other standard connections are available upon request.

3. Operation

The pressure reducing valve reduces pressure by the throttling the valve. The valve is composed of the main valve, main valve seat, a pressure adjusting air chamber, and the main diaphragm, pilot diaphragm, and pilot valve for pressure sensing and activation.

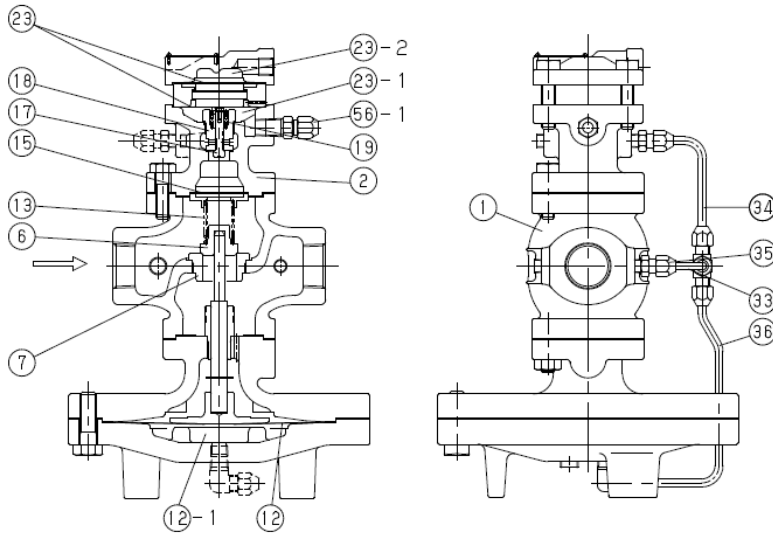

No.	Parts name
1	Body
6	Main Valve
7	Main Valve Seat
12	Main Diaphragm
13	Main Valve Spring
15	Screen
17	Pilot Valve
18	Pilot Valve Seat
23	Pilot Diaphragm
23-2	Air pressure sensing port
33	Tee
34,35,36	Pipe A,B,C
12-1	Main diaphragm chamber
23-1	Pilot diaphragm chamber
56-1	Reduced pressure sensing port

(1) When the pressure reducing valve is mounted correctly, the main valve [6] and pilot valve [17] should be closed by main valve spring [13] and pilot valve spring [19] when air pressure is no-pressure. Slowly open the gate valve and allow the high-pressure fluid to flow in. Inlet pressure is applied to the upside of the main valve. High pressure fluid passes through screen [15] to also apply inlet pressure to the downside of the pilot valve. (Fig. 1)

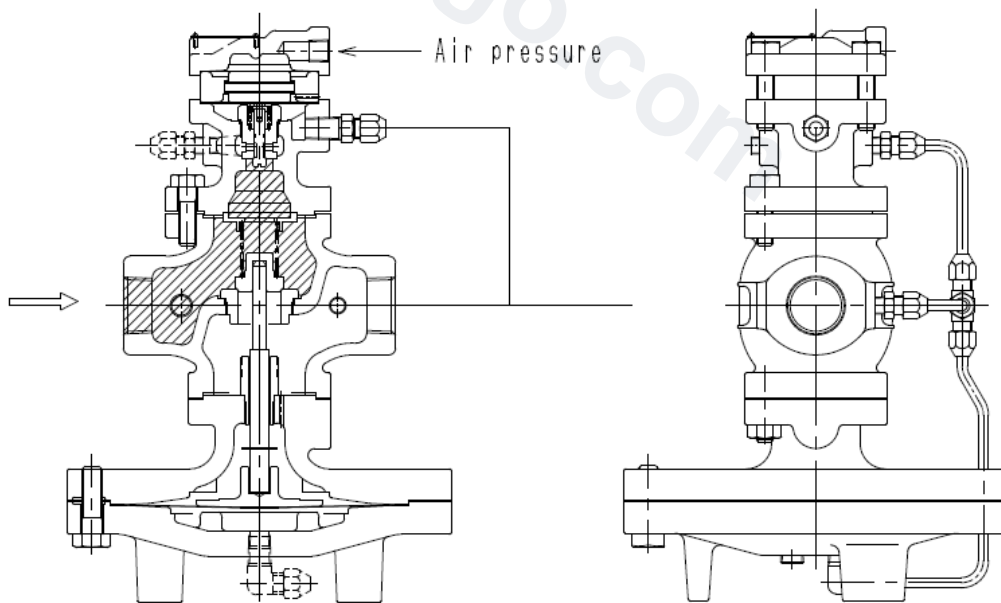

Fig.1

- (2) Introducing air pressure into air chamber flexes pilot diaphragm [23] to open the pilot valve. The fluid passing through pilot valve [17] and pilot valve seat [18] enters the main diaphragm chamber [12-1] via pipes [34] and [36]. This fluid also flows to the reduced side of the body [1] through the orifice of tee [33] and pipe [35] that connects to the body. (Fig. 2)

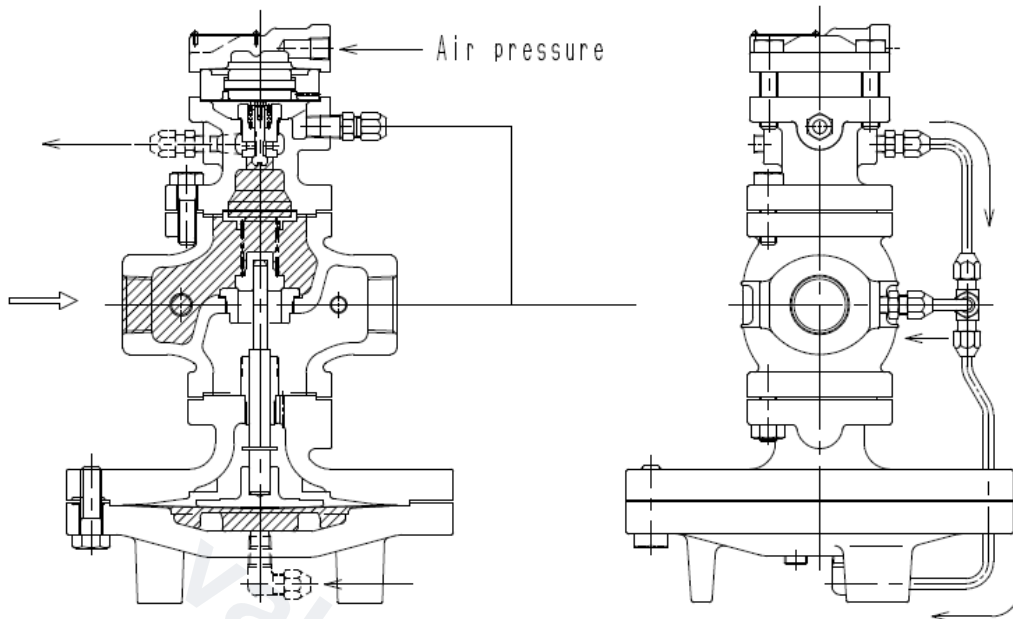

Fig.2

- (3) When the flow rate at the pilot valve exceeds the flow rate at the orifice, operating pressure in the main diaphragm chamber raised and overrides the pressure on the upside of the main valve and the load of main valve spring [13] to open the main valve. The fluid then begins to flow from the inlet side. (Fig. 3)

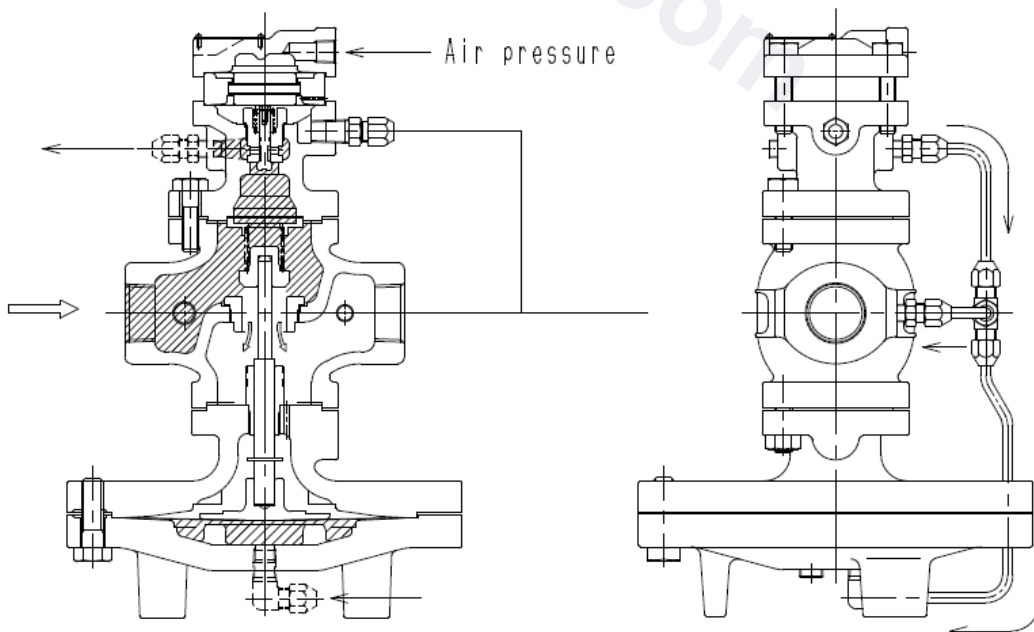

Fig.3

- (4) Reduced pressure is led to the pilot diaphragm chamber [56-1] via the sensing pipe and reduced pressure sensing port [23-1]. The pilot diaphragm receives the reduced pressure to be balanced with the air pressure. The pilot valve travel is controlled by the air pressure and pressure applied to the pilot diaphragm due to variations in reduced pressure. This changes the flow rate of fluid to the main diaphragm chamber, which controls the main valve travel to obtain appropriate reduced pressure. (Fig. 4)

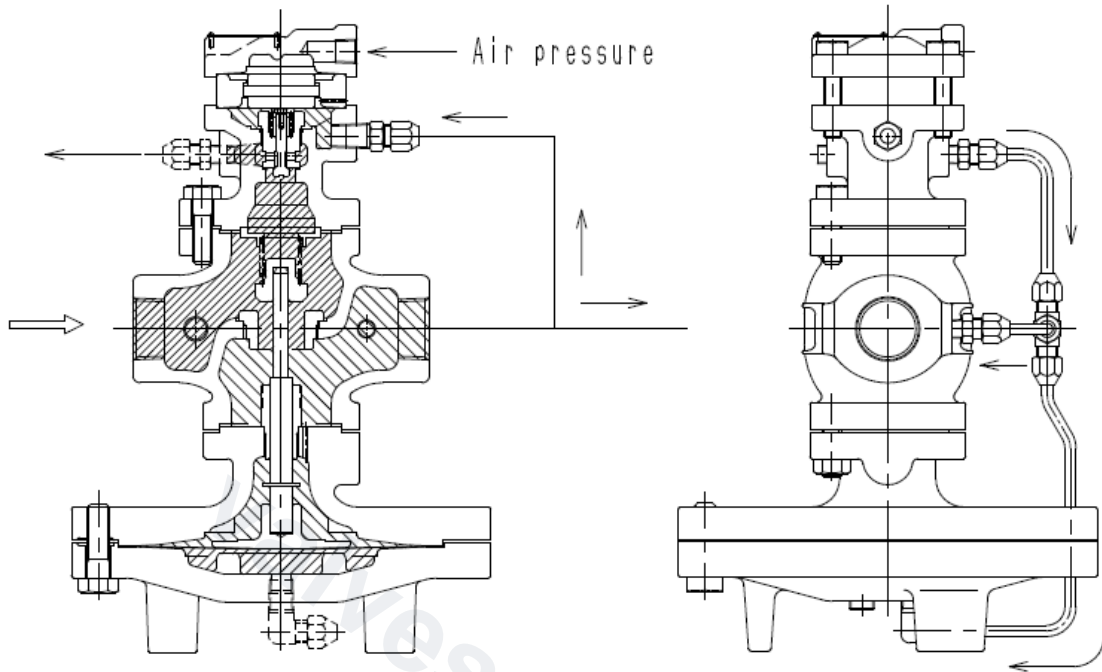
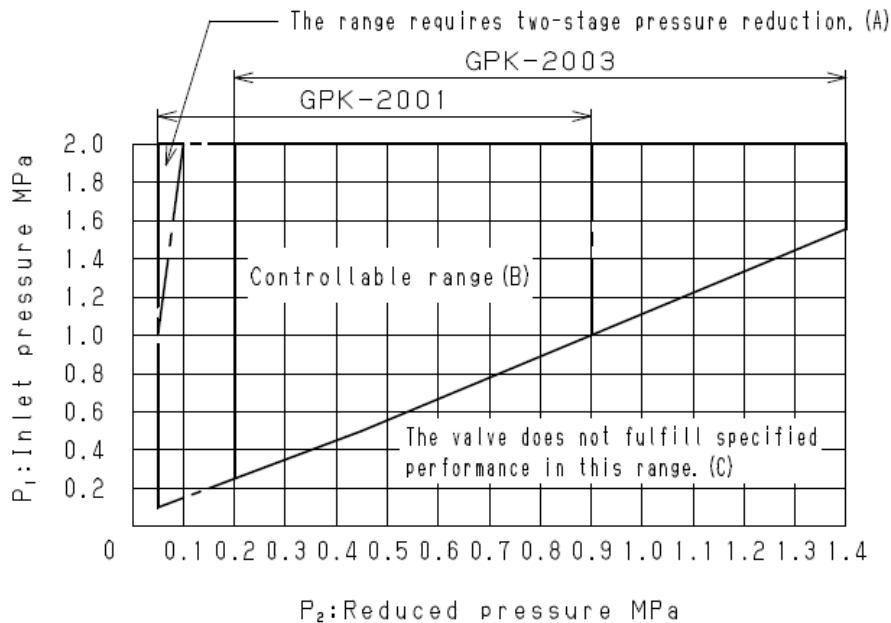

Fig.4

4. Nominal Size Selection Method

4.1 Pressure reducing valve specification selection chart



Refer to the above selection chart to select the most appropriate pressure reducing valve. Find the point of intersection of inlet pressure (P_1) and reduced pressure (P_2). When the point of intersection is within range (A), reduce pressure in two stages. When within range (C), maximum performance cannot be obtained. When reducing pressure in two stages, maximize the distance between the valves (at least 3 m).

4.2 Safety valve setting pressure chart

This chart is for setting the safety valve (for alarms) used for steam pressure reducing valves.

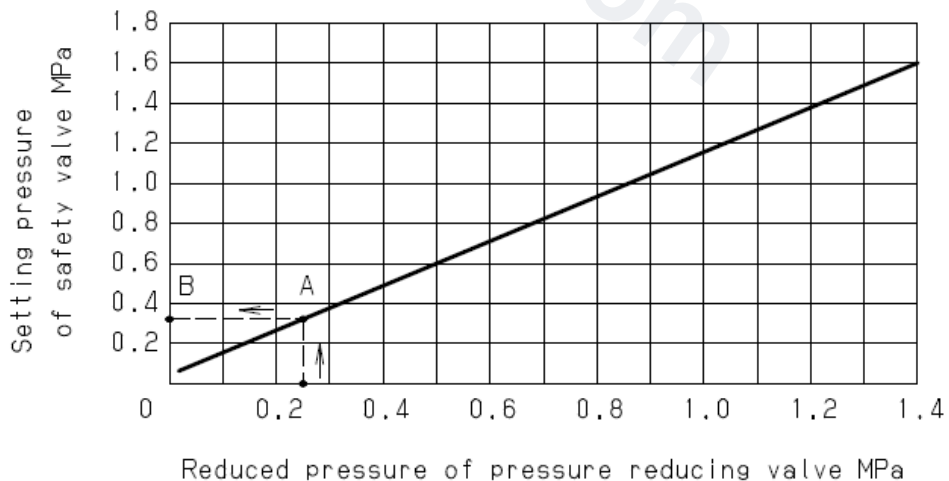

Determine the reduced pressure of pressure reducing valve. Find the intersection point (A) with the chart curve. Next, find point (B) by proceeds horizontally from point (A) to the left until the 'Setting pressure of safety valve' axis. The setting pressure of the safety valve should be higher than the pressure of the point (B).

4.3 Characteristic chart

(1) Flow rate characteristics chart

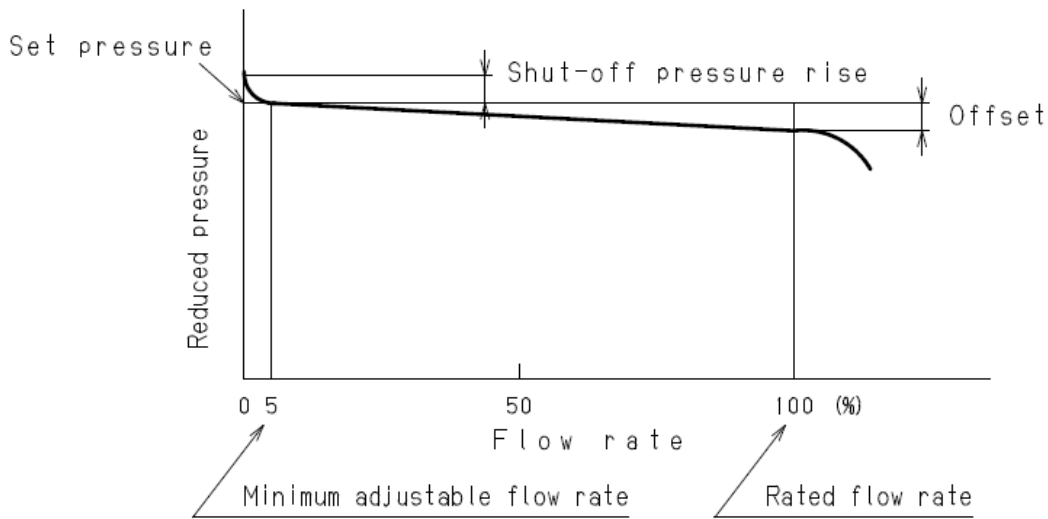

- Shut-off pressure rise: 0.02 MPa or less
- Offset: 10% or less of set pressure at outlet side (Minimum value: 0.0MPa)

Using the nominal size selection chart, select the nominal size of 80 ~ 90% of the flow rate, considering pressure loss and heat loss of the gate valve and the strainer before and after the pressure reducing valve. To fully utilize the flow characteristics of the valve, do not select a small pipe size, considering the effects due to pipe resistance.

(2) Pressure characteristics chart

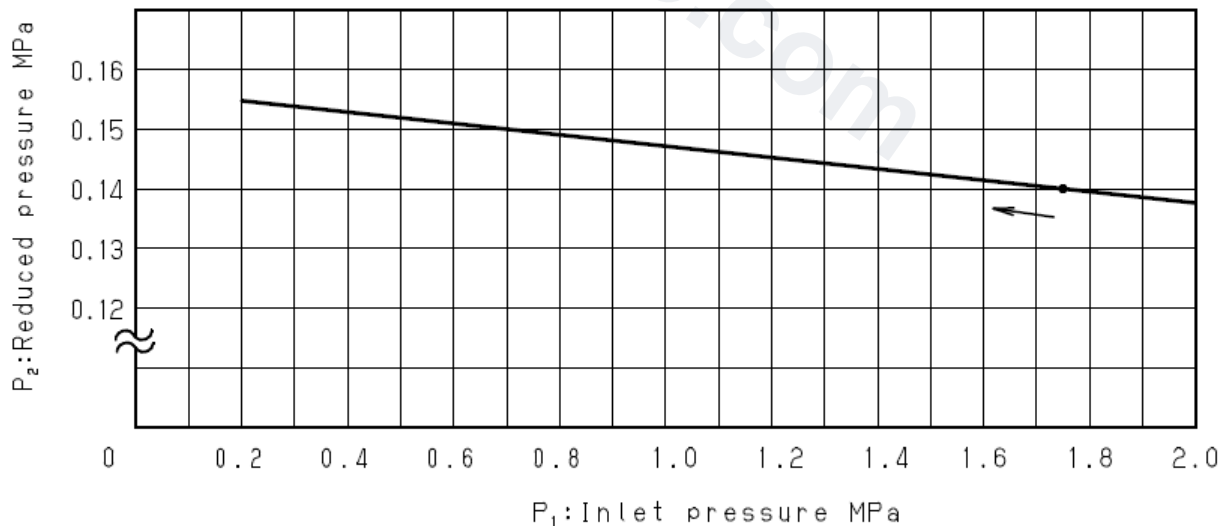

Reduced pressure is set to 0.14 MPa when inlet pressure is 1.75 MPa. The chart indicates a variation in reduced pressure when the inlet pressure is changed within the range of 0.2 to 2.0 MPa.

4.4 Nominal size selection chart (External sensing)

* Please contact us on internal sensing method.

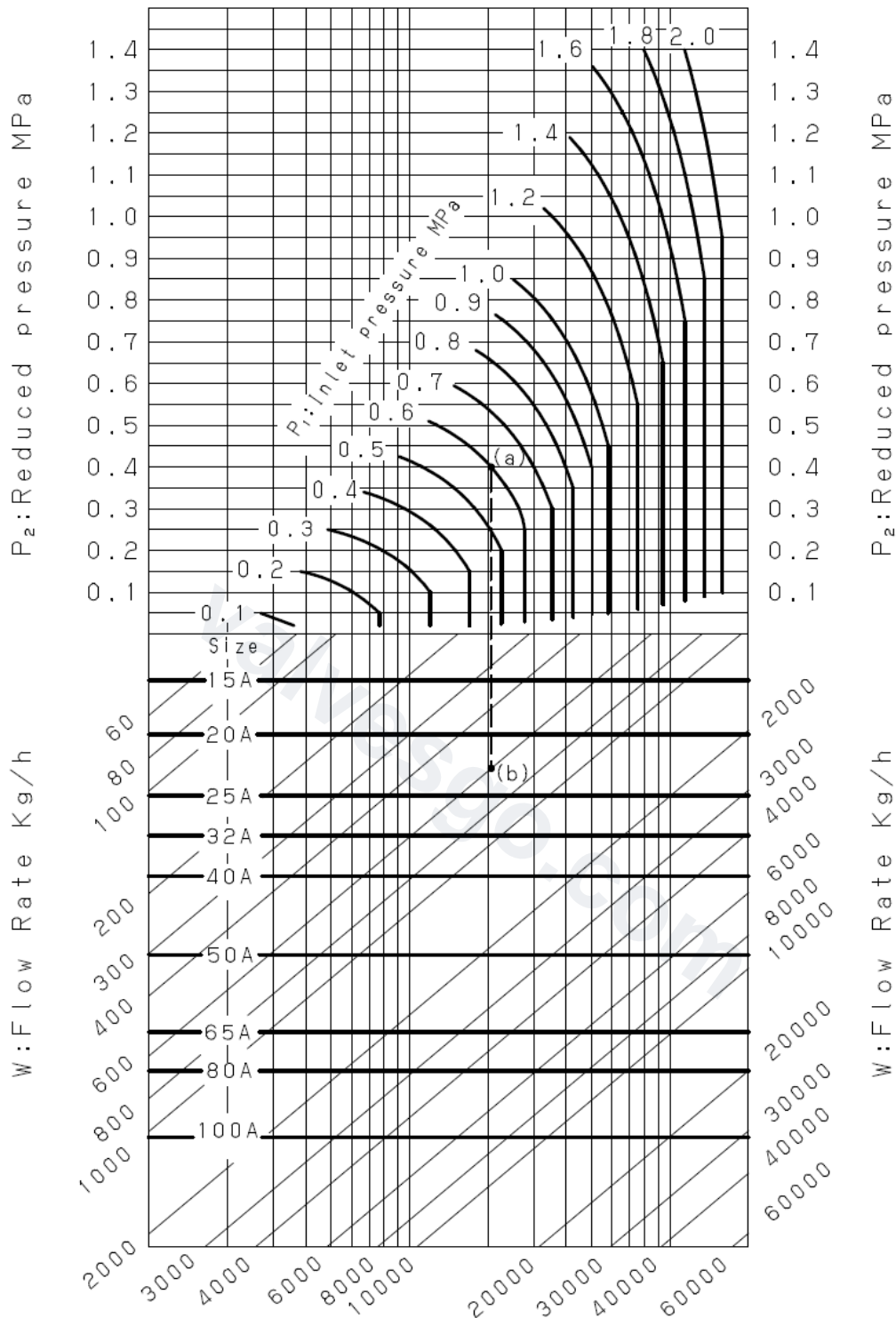

For example, take a pressure reducing valve whose inlet pressure (P₁) is 0.6 MPa, reduced pressure (P₂) 0.4 MPa, flow rate 600 kg/h. When determining the nominal size, find the point of intersection (A) of inlet pressure 0.6 MPa and reduced pressure 0.4 MPa. Vertically proceed from point (A) to come across the flow rate 600 kg/h, and regard this point as (B). Point (B) is between nominal sizes 20A and 25A. Select the larger nominal size (in this example, nominal size 25A)

4.5 Nominal size selection calculation formula

An appropriate nominal size can be calculated by obtaining Cv value for the operating conditions in question, as shown below.

- Calculation formula for Cv value

$$P_2 > \frac{P_1}{2}$$

$$C_v = \frac{Wk}{138\sqrt{\Delta P(P_1 + P_2)}}$$

$$P_2 \leq \frac{P_1}{2}$$

$$C_v = \frac{Wk}{120P_1}$$

W: Max. steam flow rate [kg/h]

P₁: Inlet pressure [MPa·A]

P₂: Reduced pressure [MPa·A]

ΔP: P₁ - P₂ [MPa]

k: 1+0.0013× {superheated steam
temp.[°C] - saturated
steam temp. [°C]}

- Rated Cv value table (External sensing)

Nominal size	15A	20A	25A	32A	40A	50A	65A	80A	100A
Cv value	5.0	7.2	10.9	14.3	18.8	32	54	70	108

* Please contact us on Cv value of internal sensing method.

[Example]

The flow rate of the pressure reducing valve is calculated under the following conditions: Nominal size 15A, saturated steam, Inlet pressure of 0.6 MPa = 0.7 [MPa A], Reduced pressure of 0.4 MPa = 0.5 [MPa A], you can find that Cv value of 15A is 5.0 from the chart. The following formula is established.

$$P_2(= 0.5) > \frac{P_1(= 0.7)}{2}$$

$$W = \frac{138 C_v \sqrt{\Delta P(P_1 + P_2)}}{k} = \frac{138 \times 5.0 \times \sqrt{0.2 \times (0.7 + 0.5)}}{1} = 338 \text{ kg/h}$$

* Use a safety factor of 80 to 90% for nominal size selection in view of friction losses in piping.

5. Installation

5.1 Precautions for installation

Warning

- (1) Since the product is heavy, securely support it using lifting devices or the like when installing. See the product weight specified in “2. Dimensions and Weights”.
- * Failure to follow this notice may cause falling accident of the product, resulting in bodily injury.

Caution

- (1) Do not disassemble the valve unreasonably.
- * Disassembling the valve at your discretion may affect the original performance.
- (2) Before installing the product, remove foreign substances and scale from the piping.
- * Failure to follow this notice may prevent the product from achieving its intended performance due to the ingress of foreign substances and scale into the product.
- (3) Install the valve so that the arrow on the valve body coincides with the direction of the fluid flow.
- * Failure to do so may prevent the valve from functioning.
- (4) Install the valve perpendicularly to horizontal lines with the diaphragm chamber located at the top.
- * Failure to do so may prevent the valve from functioning.
- (5) Do not connect the sensing pipe close to valves and elbows. Choose the position with the least vibration. (Recommended straight length: 10 times the line pipe diameter)
- * Failure to do so may cause inconsistent reduced pressure, which hampers correct pressure control.
- (6) Do not apply excessive load, torque or vibration to the valve.
- * Doing so may result in malfunction or drastically shortened service life.

5.2 Installing accessories

Warning

- (1) When installing the pressure reducing valve, be sure to connect the provided sensing pipe and joint.
- * Unless the sensing pipe is connected, the valve will not operate. Further, steam may blow off, resulting burns.

[Sensing pipe connection method]

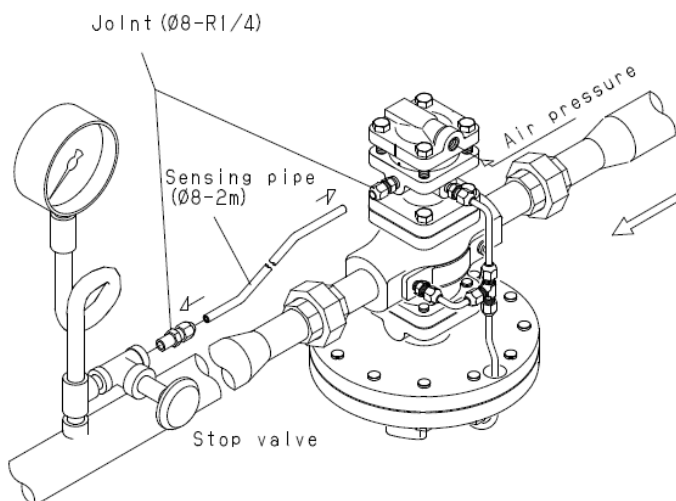

Connect the provided sensing pipe ($\varnothing 8-2m$) and joint ($\varnothing 8-R1/4$) as shown in the illustration on the left.

1. Wind sealing tapes around the joint and insert the joint into the pressure sensing side.
2. Fully insert the sensing pipe into the valve and the pressure sensing side joint. Tighten the cap nut until it can no longer be rotated manually, and then turn the cap nut about one and quarter times with a tool. Note that the sensing pipe must be connected so that the valve side is higher than the pressure sensing side.

5.3 Piping before and after the pressure reducing valve

Warning

- (1) When installing a safety valve for equipment protection at the outlet side of the product, connect a blow-off pipe to the outlet side of the safety valve, and lead it to a place where there is no risk of physical damage even if fluid blows out.
* Failure to follow this notice may result in injury and scalds in case of fluid blow out.

Caution

- (1) Install a strainer (80 mesh) at the pressure reducing valve inlet side. Also, match the nominal diameter of the strainer to the diameter of the piping on the inlet side of the pressure reducing valve.
* Failure to do so may hamper correct pressure control, which affects the original performance.
- (2) Install a safety valve for equipment protection at the outlet side of the product.
* Failure to follow this notice may prevent the product from achieving its intended performance due to the ingress of foreign substances and scale into the product.
- (3) Install a pressure gauge at both the inlet and outlet sides of the valve.
* Failure to do so may hamper correct pressure adjustment.
- (4) Install a steam trap to the inlet sides of the valve to prevent drainage problems.
* Failure to do so may result in drainage problem, affecting the original performance.
- (5) When installing quick open and close valves, such as a solenoid valve, install it at inlet side as much as possible, and secure at least 3 m from the valve.
* Failure to do so may result in malfunction or drastically shortened service life.
- (6) When pressure reducing in two stages, secure at least 3 m between the valves.
* Failure to do so may result in malfunction, affecting the original performance.
- (7) When the pressure reducing ratio is large, install a reducer to keep the flow velocity in the pipe below 30 m/s or less.
* An excessively high flow velocity may cause erosion, resulting in drastically shortened service.
- (8) Install a bypass pipe around the pressure reducing valve. (Refer to 5.4 Piping example)
* Without a bypass pipe, it would be necessary to stop operation during maintenance and inspection.
- (9) Space is required above and below the center of the piping and on the conduit side for overhaul inspection, so secure the space shown in Fig. 5 when piping.

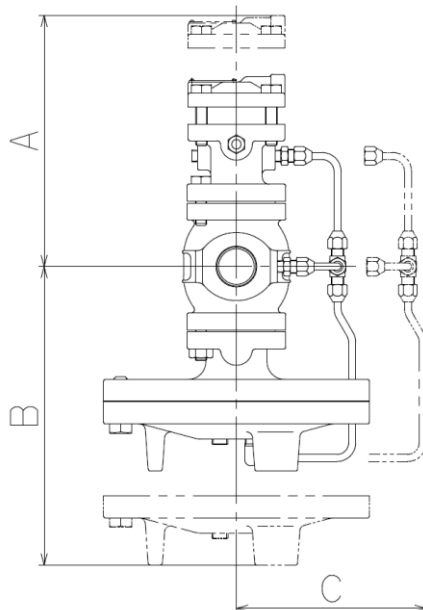

Nominal size	A		B	C
	GPK-2001	GPK-2003		
15A	240	260	340	180
20A			350	
25A	250	270	380	200
32A				
40A	290	310	430	220
50A	310	330	370	260
65A	320	340	390	
80A	350	370	470	280

Fig.5

5.4 Piping example

The remote pressure reducing valve can set several levels of pressure with a single pressure reducing valve depending on how the pneumatic circuit for operation is constructed, and automatic control is possible with a solenoid valve.

[Standard operating circuit]

The standard unit's air pressure reducing valve inputs air pressure to the remote pressure reducing valve to input the desired pressure. Use the manual three-way switching valve to turn the air pressure ON/OFF. Also, by using a three-way solenoid valve as shown in Fig. 7, automatic ON-OFF control is possible.

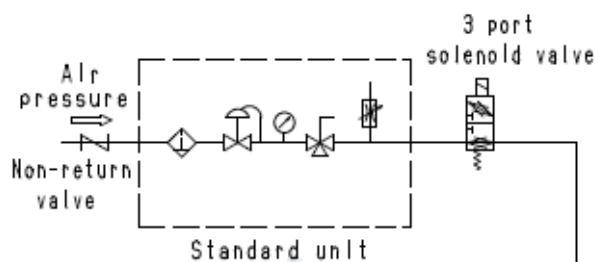

[Combination operation circuit]

Two sets of units are used, each of which is pre-adjusted to an arbitrary air pressure, and the pressure corresponding to each air pressure is output from the remote pressure reducing valve by switching the solenoid valve.

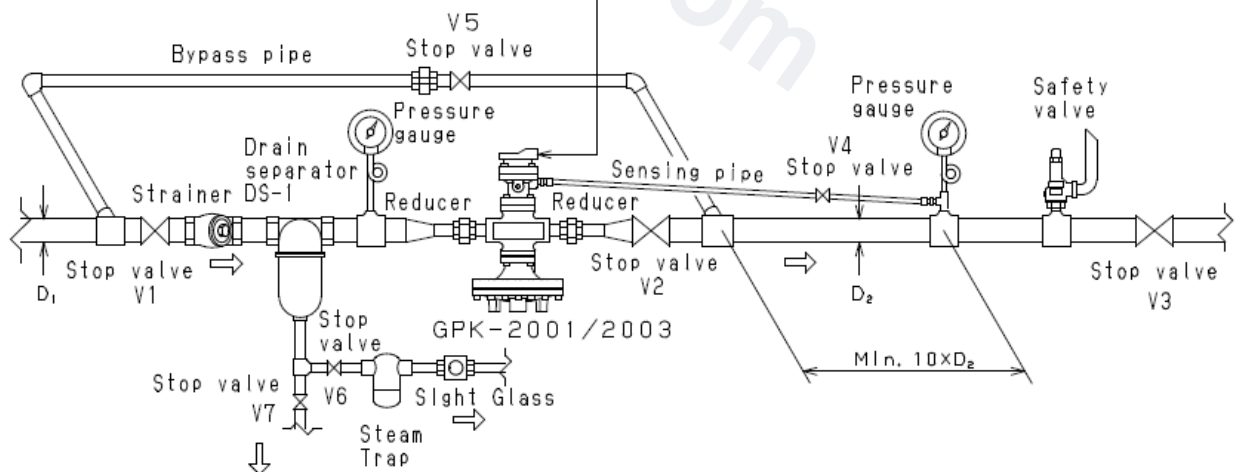
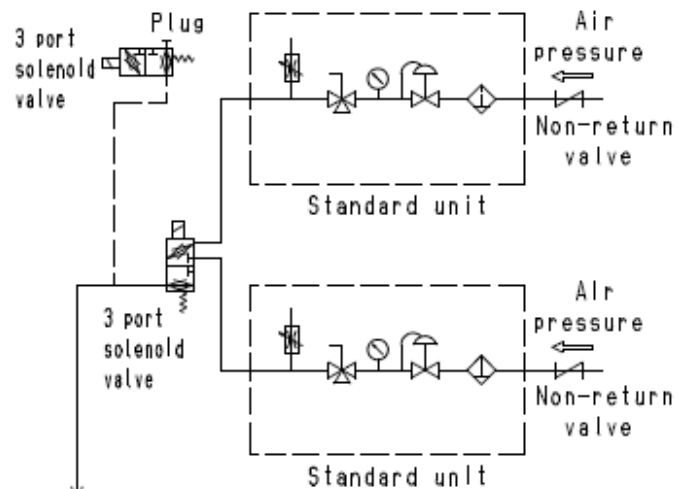

[Note]

The needle valve of the standard unit prevents pressure fluctuations due to volumetric expansion of air heated by steam above the remote pressure reducing valve and the effects of volumetric changes in the operating air pressure chamber. If the operating pressure - set pressure basic diagram will deviate slightly. In such cases, change the operating pressure to achieve the required set pressure.

6. Operating Procedure

6.1 Precautions for operation

Warning

- (1) Do not touch the product with bare hands directly.
* Failure to follow this notice may result in scalds.
- (2) Before applying steam to the product, confirm that there is no risk when steam flows into the piping end and that piping joints are securely connected.
* Failure to follow this notice may result in scalds in case of steam blow out.

Caution

- (1) Before leading fluid into the product, close the stop valves at the inlet and outlet of the product and remove foreign substances and scale from the piping completely by using a bypass line.
* Failure to follow this notice may prevent the product from functioning properly due to the ingress of foreign substances and scale into the product.
- (2) Adjust pressure of the bypass stop valve manually to prevent the outlet pressure from going over the set pressure of the safety valve.
* If going over, the safety valve blows out.
- (3) Before stopping operation of the product for an extended period, completely discharge fluid from the product and close the stop valves at the inlet and outlet sides of the product.
* Failure to follow this notice may cause malfunction due to rusting inside the product and the pipes.

6.2 Adjustment procedures

Follow the steps below, and slowly turn the adjusting screw to set pressure. Incorrect adjustment may cause hunting, water hammer, etc., resulting in damage to the valve and other equipment. (See "5.4 Example of piping".)

- (1) Check that all stop valves (V_1 to V_7) are closed.
- (2) Open the stop valve (V_6) for the trap installed before the pressure reducing valve.
- (3) Open the stop valve (V_3) and adjust the valve travel of the by-pass line stop valve (V_5).
Taking enough time not to blow the safety valve, blow off the fluid to remove foreign matter. After blowing, close the by-pass line glove valve.
- (4) Set the operating air pressure to no pressure.
- (5) Open the sensing pipe stop valve (V_4).
- (6) Open the stop valve (V_2) at the outlet side of the pressure reducing valve. Adjust the travel of the stop valve (V_3) so that a little fluid flow.
- (7) Confirm that the condensation is discharged from the inside of the pressure reducing valve, and slowly open the stop valve (V_1) on the inlet side.
- (8) While watching the pressure gauge on the secondary side, increase the operating air pressure with a standard unit, etc., and adjust to the desired pressure. Be sure to release a small amount of operating air pressure with a needle valve. (For the needle valve of the standard unit, open the valve opening by 1/2 to 1 turn.)
- (9) Slowly open the stop valve (V_3) and make fine adjustments so that the secondary pressure is the desired pressure.
- (10) When the adjustment is completed, secure the handle of the standard control unit's pressure reducing valve.
- (11) Check for leakage. Conduct re-tightening as necessary.

7. Maintenance Procedure

7.1 Troubleshooting (Refer to “7.5 Exploded drawing”.)

Problem	Cause	Solution
Pressure does not reach the desired value.	<ol style="list-style-type: none"> 1. Incorrect pressure is being used. 2. Insufficient operating air pressure. 3. Screen [15] is clogged. 4. Main diaphragm [11] is damaged. 5. Orifice of tee [33] is clogged. 6. Pilot valve [17] and pilot valve seat [18] are clogged with foreign matter, scales, etc. 7. Sensing pipe is clogged. 8. Nominal size is too small for the specifications. 9. Pressure is not adjusted correctly. 10. Wrong installation with tee [33] 11. Strainer installed before pressure reducing valve is clogged. 12. Pressure gauge is faulty. 	<ol style="list-style-type: none"> 1. Correct the pressure. 2. Increase the operating air pressure to the desired set pressure. 3. Disassemble and clean the screen. 4. Replace the main diaphragm. 5. Remove the tee and clean it. 6. Disassemble pilot valve assembly, and clean it. 7. Disassemble and clean it. 8. Change the nominal size appropriately. 9. Observe the adjustment procedures and readjust pressure. 10. Install the tee whose slit should be faced upward. 11. Disassemble and clean it. 12. Replace it.
Reduced pressure raises above than the specified value.	<ol style="list-style-type: none"> 1. Operating air pressure too high. 2. The relief of the operating air pressure is small. 3. Foreign matter exists between main valve [11] and main valve seat [12], or scratches exist. 4. Foreign matter exists between pilot valve and pilot valve seat, or scratches exist. 5. Orifice of tee [33] is clogged. 6. Reduced pressure is not adjusted correctly. 7. Foreign substances stuck between the spindle [8] and the guide [9]. 8. Trap is not provided for dead-end line. 9. By-pass valve is leaking. 	<ol style="list-style-type: none"> 1. Decrease the operating air pressure. 2. Release a little of the operating air pressure with a needle valve, etc. (Refer to “5.4 Piping example”.) 3. Disassemble and remove the foreign matter. When any scratches are identified, lap the main valve and main valve seat. Change the parts if scratches still exist after lapping. 4. Disassemble the pilot valve assembly, and clean or replace it. 5. Remove the tee and clean it. 6. Observe the adjustment steps and readjust pressure. 7. Disassemble the product and remove the foreign substances. 8. Install a trap. 9. Repair or replace it.
Abnormal noise is heard.	<ol style="list-style-type: none"> 1. Orifice of tee [33] is clogged. 2. Nominal size is too large for the specifications. 3. Pressure reducing ratio is too large. 4. Drainage problem is caused. 5. A quick operating valve installed near the product. 6. Outlet pipe diameter is too small. 7. No or too much operating air pressure relief. 	<ol style="list-style-type: none"> 1. Remove the tee and clean it. 2. Change the nominal size appropriately. 3. Reduce pressure in two stages. 4. Install a trap. 5. Place the quick operating valve more than 3 meters away from the product. 6. Select a pipe size that will produce a flow velocity of 30m/s or less. 7. Set correctly.

- Foreign matter and scales in a pipe may cause most of problems of pressure reducing valve. Be careful sufficiently to foreign matter in a pipe.
- Phenomenon alike valve trouble may happen by fault of pressure gauge, fluid leakage from by-pass valve, forgetting to close the by-pass valve, clogging strainer, and etc. First, check the said before above troubleshooting.
- Consult factory when cannot make a judgement whether parts need replacement or not.

7.2 Precautions for maintenance and inspection

Warning

- (1) Completely discharge internal pressure from the valves, lines, and equipment, and cool the valve down to a level where you can touch it with bare hands before disassembly and inspection.
- * Failure to do so may result in injury or burns due to residual pressure or spillage around the valve.

Caution

- (1) Pressure reducing valve shall be disassembled and inspected by qualified person or manufacture.
- * Request the treatment to specialized dealer or manufacture in case of any problems.
- (2) While disassembly, drain flow out from the valve, so catch it by container. And release steam completely before disassembling.
- * In case of no container for drain, it makes dirty surrounding the valve.
- (3) Close the stop valves before and after the pressure reducing valve, and remove all foreign matter and scales via the by-pass line before operation.
- * Failure to do so may prevent the valve from functioning correctly.
- (4) Remove condensate completely from the line, and close the stop valves before and after the valve when not using it for long periods of times.
- * Rust generated in the valves and lines may cause malfunction.
- (5) In case of no operation for a long period of time, perform operating exam before start operation again.
- * Request the treatment to specialized dealer or manufacture in case of any problems.

7.3 Disassembly

Be sure that the stop valves at inlet and outlet side of pressure reducing valve is closed and all internal pressure and condensate have discharged before disassembling the valve.

(1) Pilot valve

1. Set the operating air pressure to no pressure.
2. Remove bolt [60] of cover [57].
3. For GPK-2001, remove the pilot diaphragm [23], the diaphragm case [58], and pilot diaphragm plate [59].
3. Remove pilot valve assembly using a ring spanner or socket wrench (nominal size 22).

(2) Main valve

1. Remove pipe A [34] at joint A [30] or tee [33].
2. For nominal sizes 15A to 40A, remove bolt [38] of pilot body [2]. Dismount the pilot body from the body [1]. And remove spring plate [14], screen [15], main valve spring [13], and main valve [6]. For nominal sizes 50A to 100A, remove bolt [44] of spacer [54] and remove the spacer from the main body [1], main valve spring [13], and entire main valve ([6], [9], [50], and [51]) (for nominal size 50A, main valve spring, and main valve [6])

(3) Main diaphragm

1. Remove pipe C [36] at tee [33].
2. Remove bolt [41] of bottom dia. case [5]. Dismount the bottom dia. case, main diaphragm [12], retainer [11], and spindle [9] (adapter [52] and retainer [11] for nominal sizes 65A to 100 A).

7.4 Precautions for disassembly

 **Caution**

- (1) Check that there is no damage and scratches on the main valve, main valve seat, pilot valve, and pilot valve seat.
 - * Any scratches at sealing surface lead to increase in secondary pressure. When any scratches are identified at main valve and seat, polish them away. And, change the parts if scratches still exist after polishing. Also, in case any scratches are identified at pilot valve and pilot valve seat, change into pilot valve assembly.
- (2) Move the sliding section (pilot valve, piston, etc.) two to three times and confirm they move smoothly.
 - * If the sliding parts do not move correctly, it may cause failure problems. (Working not correctly).
- (3) Replace gaskets with new ones when reassembling.
 - * If the gasket is used for a long time, it may cause steam leakage problem.
- (4) Assemble in the reverse order of Disassembly. And tighten the bolts evenly.
 - * Assemble the valve due to the order. Failure to do so may lead to not assemble correctly. And if the hexagon bolts are not screwed correctly, it may cause steam leakage problem.

7.5 Exploded drawing

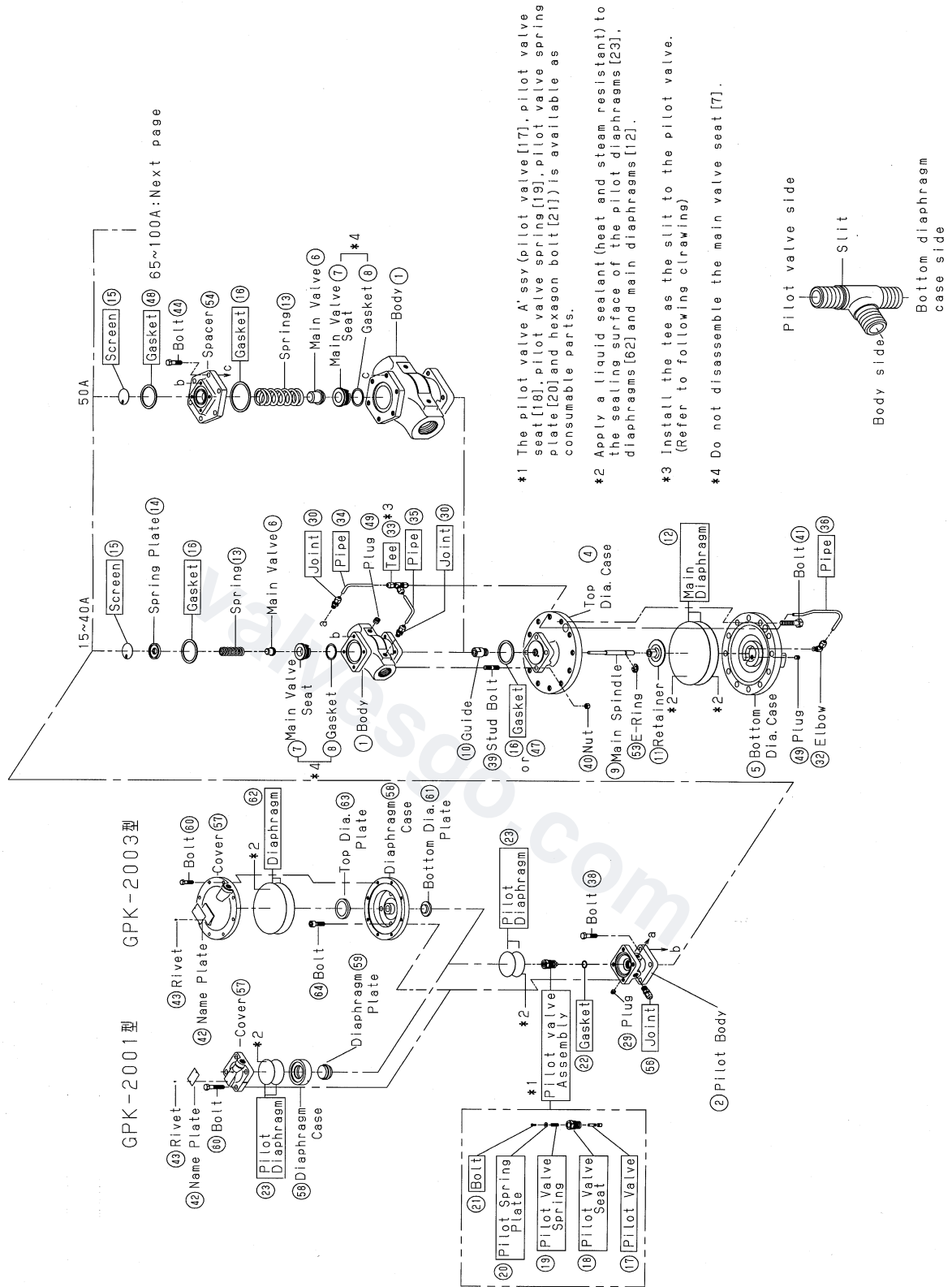

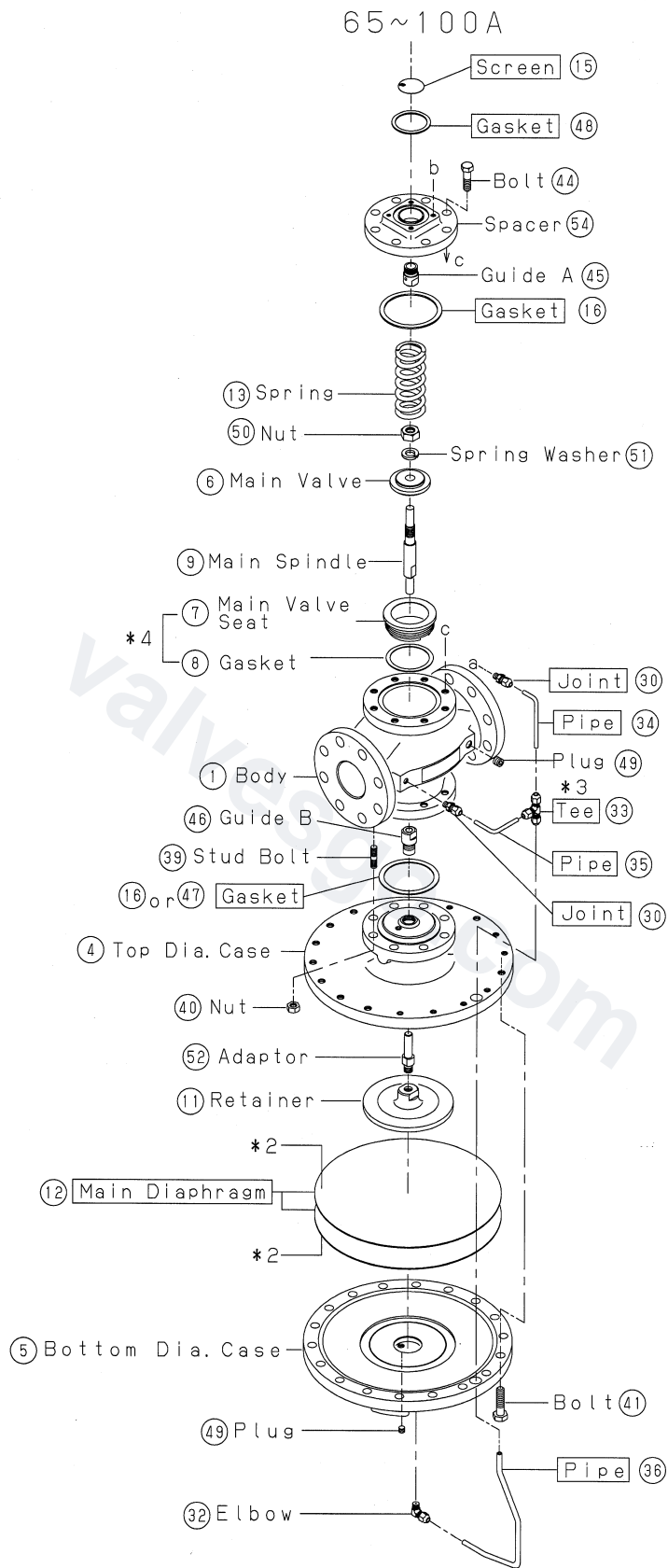

Warranty Information

1. Limited warranty

This product has been manufactured using highly-advanced techniques and subjected to strict quality control. Please be sure to use the product in accordance with instructions on the manual and the label attached to it.

Yoshitake warrants the product to be free from any defects in material and workmanship under normal usage for a period of one year from the date of receipt by the original user, but no longer than 24 months from the date of shipment from Yoshitake's factory.

2. Parts supply after product discontinuation

This product may be subject to discontinuation or change for improvement without any prior notice. After the discontinuation of the product, Yoshitake supplies the repair parts for 5 years otherwise individually agreed.

3. This warranty does not cover the damage due to any of below:

- (1) Valve seat leakage or malfunction caused by foreign substances inside piping.
- (2) Improper handling or misuse.
- (3) Improper supply conditions such as abnormal water pressure/quality.
- (4) Water scale or freezing.
- (5) Trouble with power/air supply.
- (6) Any alteration made by other than Yoshitake.
- (7) Use under severe conditions deviating from the design specifications (e.g. in case of corrosion due to outdoor use).
- (8) Fire, flood, earthquake, thunder and other natural disasters.
- (9) Consumable parts such as O-ring, gasket, diaphragm and etc.

Yoshitake is not liable for any damage or loss caused by malfunction or defect of the product.

YOSHITAKE 