



# MODEL MD-53 and MD-54 TWO WAY MOTOR VALVE

## PRODUCT MANUAL

Thank you very much for choosing the Yoshitake's product. To ensure the correct and safe use of the product, please read this manual before use. This manual shall be kept with care for future references. The symbols used in this manual have the following meanings.

	<b>Warning</b>	This symbol indicates a potentially hazardous situation that, if not avoided, could result in death or serious injury.
	<b>Caution</b>	This symbol indicates a hazardous situation that, if not avoided, may result in minor or moderate injury or may result in only property damage.

### Table of Contents

1. Overview .....	1
2. Specifications.....	1
2.1 Specifications and performance of actuator.....	2
2.2 Flow characteristics .....	3
3. Dimensions and Structure.....	4
3.1 Dimensions and structure of cable connector.....	6
4. Operation.....	7
5. Procedures for Installation, Operation and Maintenance.....	8
5.1 Precaution for installation .....	8
5.2 Precaution for operation.....	9
5.3 Manual operation .....	10
5.4 Precaution for maintenance .....	10
5.5 Troubleshooting.....	11
Warranty Information	

# YOSHITAKE

## 1. Overview

Compact size motor valve is often used as a part of automatic fluid control system in manufacturing process which has been increasingly automated.

Model MD-53 and MD-54 two way motor valves are widely used in systems of sprinkler, water supply, solar generation and air conditioning as well as in controllers for ON-OFF operation (for heating, cooling or pressurizing) or remote operation.

## 2. Specifications

Model		MD-53	MD-54		
Nominal size		15-50A			
Application		Cold and hot water, Air	Air	Cold and hot water	Steam
Working pressure		0-1.0 MPa	0-1.0 MPa		0-0.6 MPa
Fluid temperature		-15 to 80°C	Max. 120°C	Max. 100°C	Max. 160°C
Rated voltage		AC 100 / 110 V $\pm$ 10% 50 / 60 Hz			
		AC 200 / 220 V $\pm$ 10% 50 / 60 Hz			
Power consumption		16 VA (for 15-40A), 19 VA (for 50A)	16 VA (for 15-32A), 19 VA (for 40A and 50A)		
Operation		ON-OFF			
Operation angle		90°			
Opening-closing time	At 50Hz	5.4 sec (for 15-25A)	5.4 sec (for 15A, 20A)		
		15.5 sec (for 32A, 40A)	15.5 sec (for 25A, 32A)		
		16 sec (for 50A)	16 sec (for 40A, 50A)		
	At 60Hz	4.5 sec (for 15-25A)	4.5 sec (for 15A, 20A)		
		13 sec (for 32A, 40A)	13 sec (for 25A, 32A)		
		13.5 sec (for 50A)	13.5 sec (for 40A, 50A)		
Manual operation		Manually operable (Manually operable by loosening locking screw)			
Overcurrent protection		Built-in thermal protector			
Opening-closing indicator lamp circuit		Built-in			
Protective structure		Equivalent to IP65 dust and water proof structure (JIS C 0920)			
Valve shape		Reduced bore			
Material	Body	Cast stainless steel			
	Ball	Stainless steel or Cast stainless steel			
	Seat	Reinforced fluorine resin for high temperature			
Connection		JIS Rc screwed			

■ Table of Cv value

• MD-53

Nominal size	15A	20A	25A	32A	40A	50A
Cv value	12	16	28	47	83	123

• MD-54

Nominal size	15A	20A	25A	32A	40A	50A
Cv value	9	13	24	44	80	120

**2.1 Specifications and performance of actuator**

Actuator		AM1-030	AM1-070	AM1-180
Model	MD-53	15-25A	32-40A	50A
	MD-54	15A, 20A	25A, 32A	40A, 50A
Rated torque		3 N-m	7 N-m	18 N-m
Power consumption		16 VA		19 VA
Motor		Synchronous motor		
Contact capacity of signal		Resistance load: AC250V 3.0A (Min. 0.1A)		
Load time factor		20% 15 min.		
Ambient temperature		-15 to 55°C (-15 to 55°C for actuator only)		
Measure against dew condensation		Built-in space heater (1W)		
Wire lead-in port		G 3/8 cable connector (Cable of $\Phi 5.0-10.5$ )		
Terminal block		Applicable to naked wire of 0.14-1.5 mm <sup>2</sup> (AWG26-14)		

## 2.2 Flow characteristics

### ■ For saturated steam (in case of Cv value = 1)

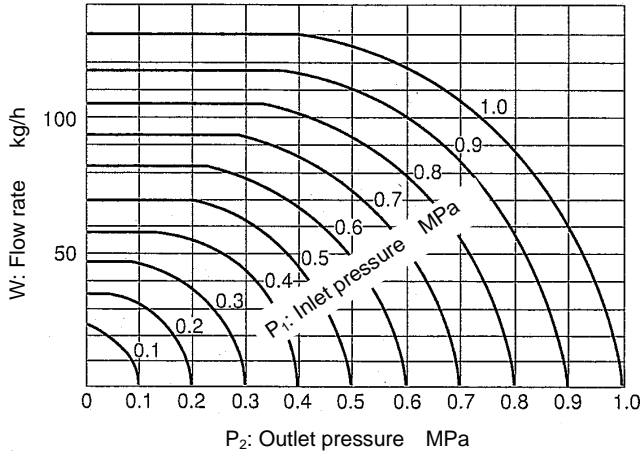

#### NOTE:

Maximum working pressure is 0.6 MPa for steam application.

### ■ For air (in case of Cv value = 1)

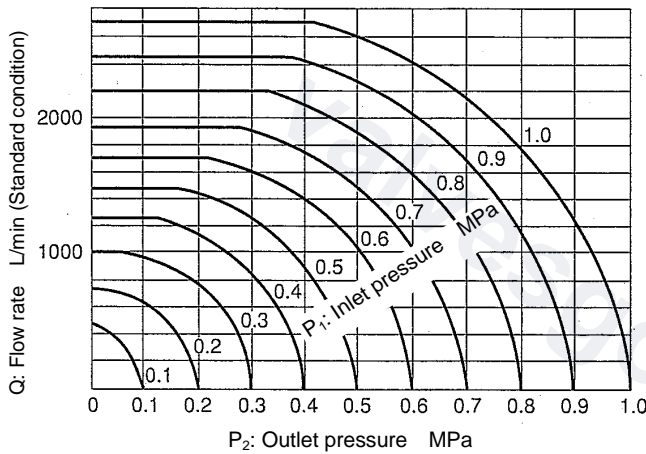

#### ● How to use the chart

Each chart shows flow characteristics at Cv = 1.

To find a flow rate at each size, multiply the value you find in the chart by each Cv value shown in page 2. The chart for air shows the flow characteristics obtained at the fluid temperature of 20°C.

<Example>

Model: MD-53,  
Nominal size: 20A,  
Inlet pressure: 0.6 MPa  
Outlet pressure: 0.5 MPa

The air flow rate at the conditions above can be obtained by the following formula.

1000 L/min (standard condition) [Find the value by using the chart for air] x 16 (Cv value) = 16000 L/min (standard condition)

### ■ For water (in case of Cv value = 1)

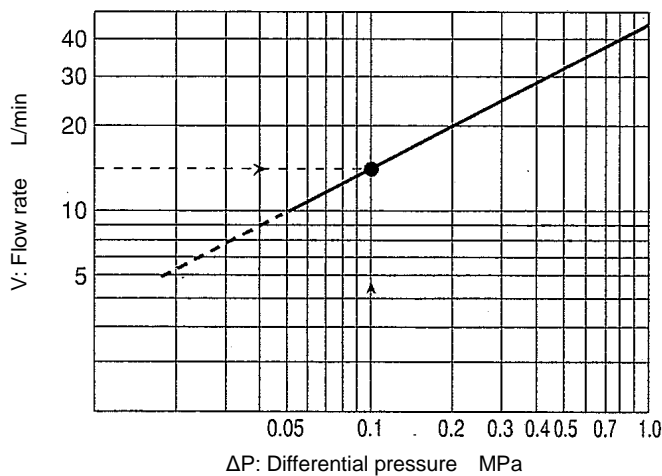

### 3. Dimensions and Structure

■ Model MD-53

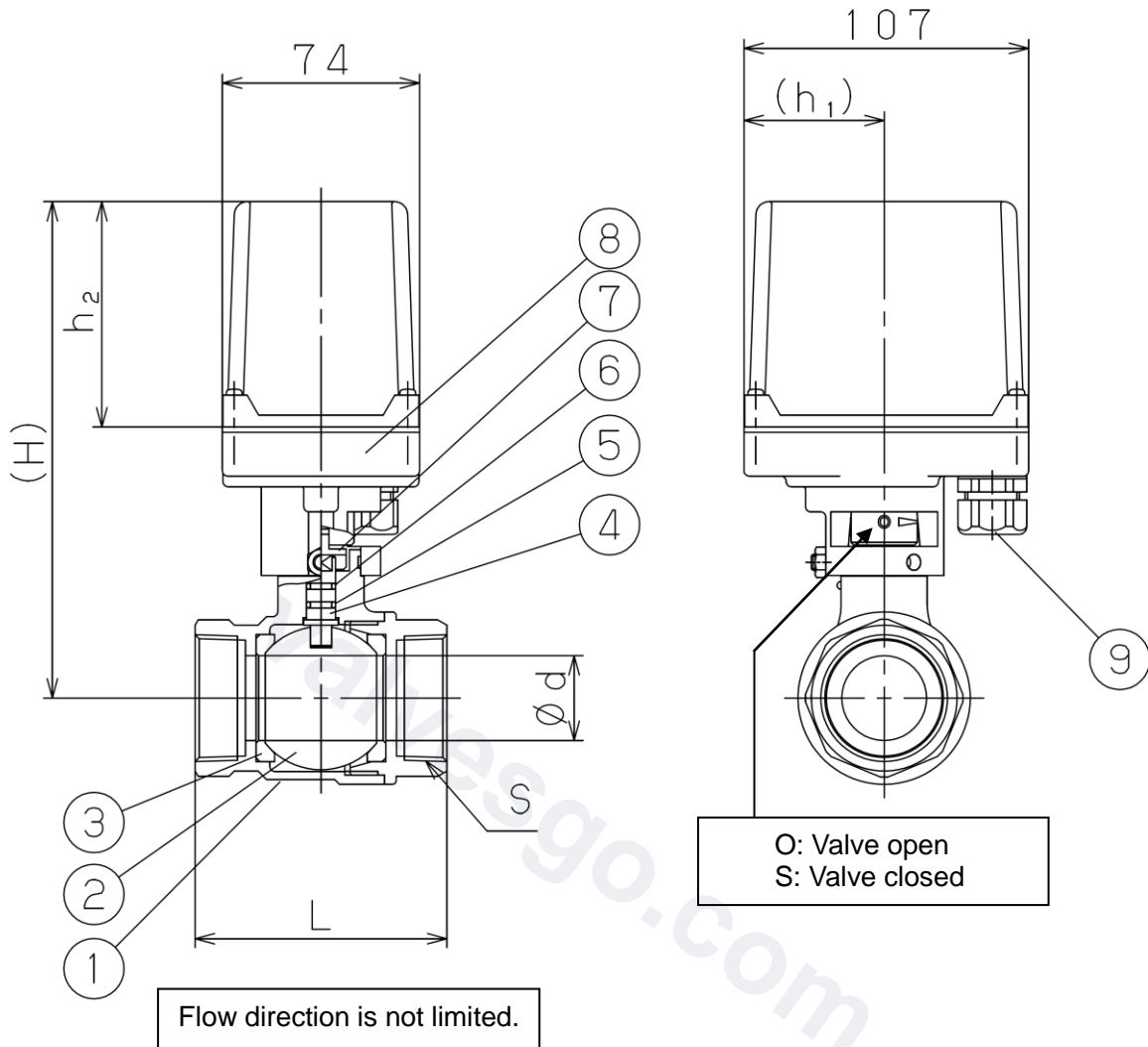

No.	Part name
1	Body
2	Ball
3	Seat
4	Stem
5	O-ring
6	O-ring
7	Connector
8	Actuator
9	Cable connector

Nominal size	(mm)						
	S	d	L	h <sub>1</sub>	h <sub>2</sub>	H	Weight (kg)
15A	Rc 1/2	13	59	36	58	121	1.3
20A	Rc 3/4	16	66	36	58	123	1.4
25A	Rc 1	20	78	36	58	129	1.6
32A	Rc 1 1/4	25	87	36	58	140	2.0
40A	Rc 1 1/2	32	95	36	58	146	2.3
50A	Rc 2	39	109	53	85	193	3.4



#### Caution

1. The valve (ball) is preset to be open at factory before shipment.

■ Model MD-54

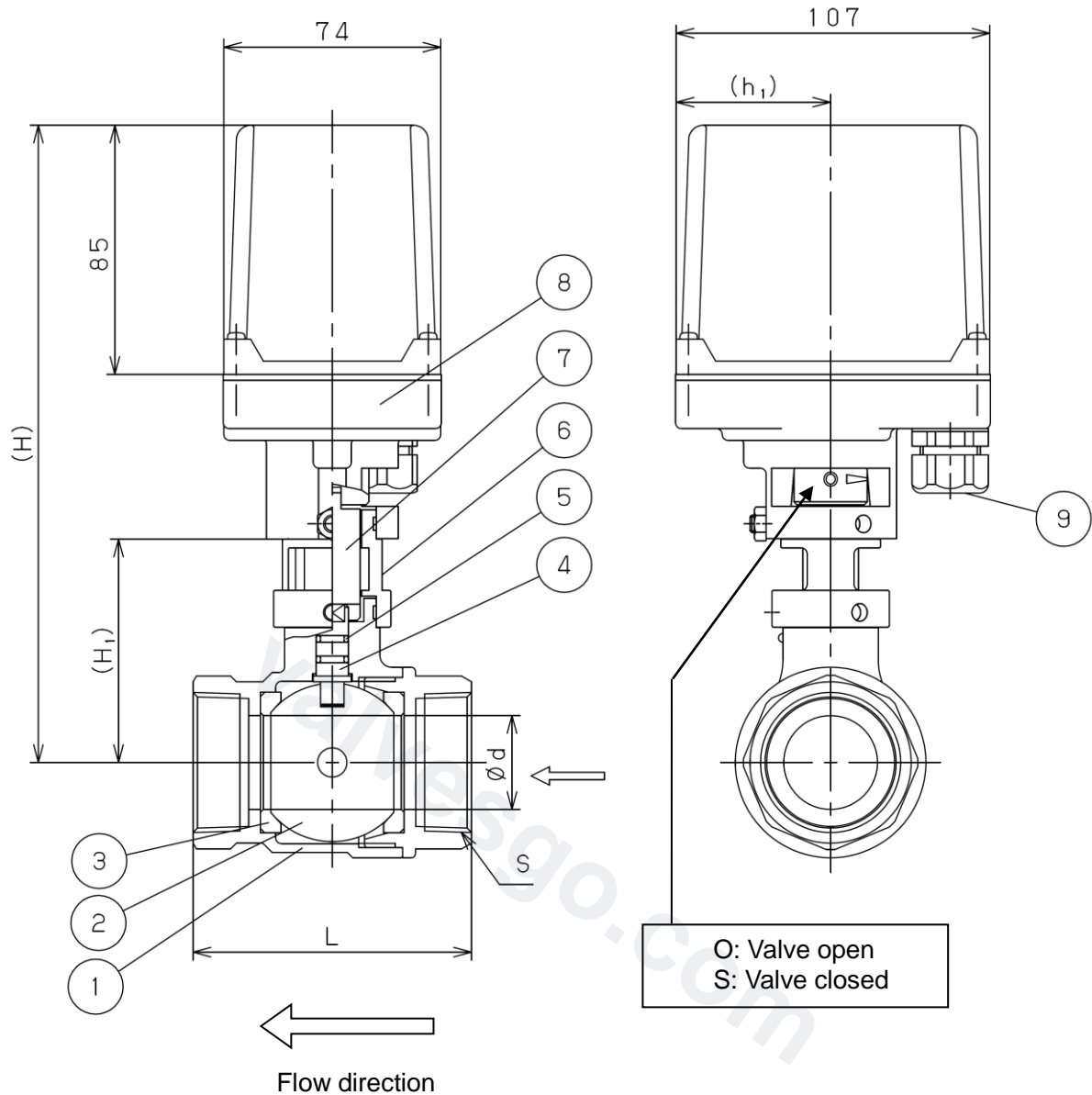

Nominal size	(mm)						Weight (kg)
	S	d	L	h <sub>1</sub>	H <sub>1</sub>	H	
15A	Rc 1/2	13	59	36	52	178	1.6
20A	Rc 3/4	15	66	36	54	180	1.7
25A	Rc 1	20	78	36	61	187	1.9
32A	Rc 1 1/4	25	87	36	71	197	2.2
40A	Rc 1 1/2	32	95	53	77	217	3.1
50A	Rc 2	40	109	53	83	223	3.7

No.	Part name
1	Body
2	Ball
3	Seat
4	Stem
5	O-ring
6	Bracket
7	Connector
8	Actuator
9	Cable connector

**Caution**

1. The valve (ball) is preset to be open at factory before shipment.
2. Flow direction is limited. Check the direction of the product so that the fluid flow and the arrow marked on the product are in the same direction.

### 3.1 Dimensions and structure of cable connector

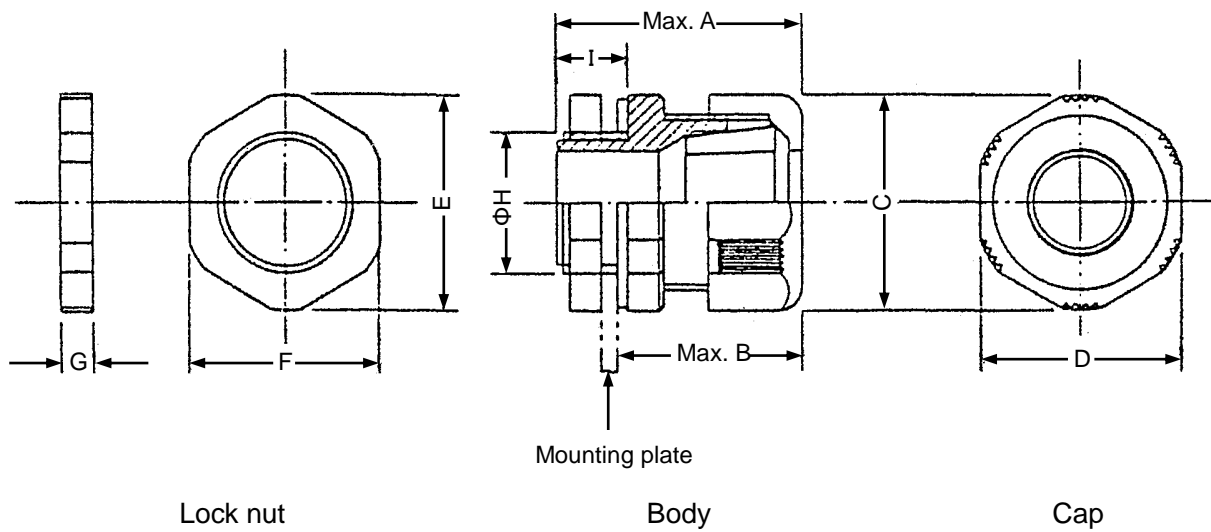

(mm)

Cable outer diameter	Parallel pipe thread	Screw outer diameter $\Phi H$	Screw length I	Mounting hole diameter
$\Phi 5.0-10.5$	G 3/8	16.7	11.0	$\Phi 17$

(mm)

Dimensions of body and cap				Dimensions of lock nut			Gasket thickness
Max. A	Max. B	C	D	E	F	G	
35.0	25.5	26.0	24.0	26.0	24.0	5.0	1.5

## 4. Operation

Actuator operates with either normal or reverse rotation. The stem connected to the output shaft rolls the ball to open or close the valve.

### ■ Operational principle

<Circuit diagram>

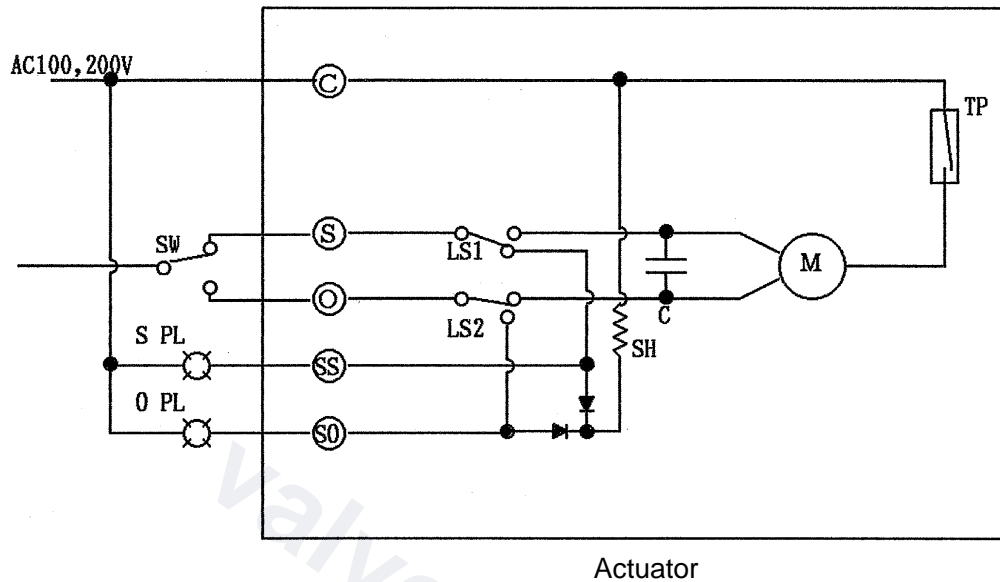

LS1, LS2: Limit switch  
C: Condenser  
SH: Space heater  
M: Motor  
TP Thermal protector

1. The valve closes as switched to [S].  
The motor stops as LS-1 (limit switch for close operation) connection is turned OFF.
2. The valve opens as switched to [O].  
The motor stops as LS-2 (limit switch for open operation) connection is turned OFF.

### NOTE

- Use an opening-closing indicator lamp circuit suitable for the specifications of power supply.
- The built-in space heater requires no extra handling because it is installed in the circuit and works automatically to prevent dew condensation inside the actuator.
- The label on the cable connector indicates the valve's opening or closing conditions.  
The valve is open when the label "O" is shown on the connector.  
The valve is closed when the label "S" is shown on the connector.

## 5. Procedures for Installation, Operation and Maintenance

### 5.1 Precaution for installation

#### Warning

1. The product is not explosion-proof. Do not use it in the area or ambience where explosive gases accumulate.  
\* Using the product under the said conditions may cause fire.
2. Connect the cables only after confirming that no power is supplied.  
\* Failure to follow this notice may cause an electric shock.
3. Connect the cables according to the instructions after confirming the rated voltage.  
\* Erroneous cable connection may cause an electric shock or fire.
4. Keep the inside of the actuator away from water ingress.  
\* Failure to follow this notice may cause an electric shock, fire or malfunction due to short circuit.

#### Caution

1. Before connecting piping to the product, remove foreign substances and scale inside the piping.  
\* Failure to follow this notice may prevent the product from functioning properly.
2. To install the product that has a specified flow direction, confirm if the direction of fluid flow matches with inlet and outlet sides of the product and install the product correctly.  
\* Setting the product in wrong directions prevents it from functioning properly.
3. Make sure to connect a strainer (80–100 mesh) to the inlet of the product.  
\* Failure to follow this notice may prevent the product from functioning properly.
4. Do not apply excessive load, torque or vibration to the product.  
\* Failure to follow this notice may result in drastically shortened service life.
5. If the product is used outdoors, place protective covers or guards above the wire connection in order to avoid exposure to water.  
\* Failure to follow this notice may cause an electric leakage.
6. If the product is used outdoors, place protective covers or guards above the product in order to avoid exposure to water.  
\* Failure to follow this notice may cause an electric leakage.
7. Do not overthread the pipe.  
\* Screwing in the overthreaded pipe may deform the product and cause malfunction of the product.
8. When installing the product, screw the pipe into the product, using a spanner set at the body end to be connected as shown below.  
\* Do not screw in the pipe with holding the bracket of the actuator. Do not screw in the pipe using a spanner set at the body end opposite from the pipe to be connected.

**OK**

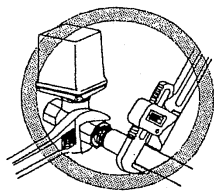

**WRONG**

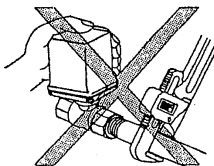

**WRONG**

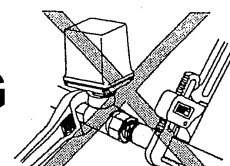

9. When installing the product, do not set a pipe wrench or apply excessive load on the product body. To correct the installation posture of the product, do not apply any force to loosen the connecting screw of the product. (Do not apply counterclockwise force to the connecting screw of the product.)  
\* Failure to follow this notice may prevent the product from functioning properly.
10. Do not dismount the actuator from the body while installing the product.  
\* Failure to follow this notice may result in part missing and malfunction.

11. Do not apply excessive torque when installing the product.  
Use the torque specified below for screwing in the pipe to avoid the product malfunction.

■ Tightening torque (N·m)

Nominal size	15A	20A	25A	32A	40A	50A
Tightening torque	25-35	40-50	50-60	60-80	75-85	90-110

12. If the surface temperature of the actuator cover exceeds 55°C due to radiant heat, equip the cover with an insulating board appropriately.
13. Installation posture
- Install the product vertically or horizontally including intermediates, but not with the actuator downward.
  - Secure the space of at least 150 mm above the actuator for maintenance.

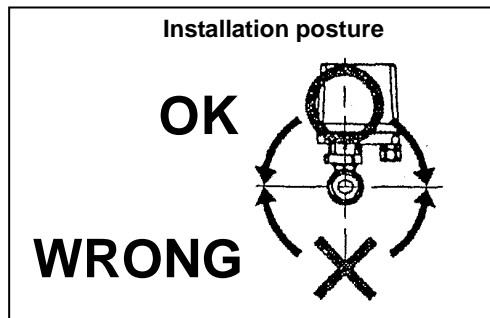

## 5.2 Precaution for operation



### Warning

1. Do not touch the product with bare hands when the product is used for hot fluid.  
\* Failure to follow this notice may result in burns.

2. After checking that the appropriate power voltage is supplied, connect the wires according to wiring diagram shown on the sticker on the actuator. Do not connect the wire to the switch signal terminal unless it is necessary.
3. The product is equipped with a reliable screw terminal block.  
Make a cut around the insulation of the wire by 5.5 mm from the edge, and connect it to the terminal.
4. Take measures against electric shock, such as using an earth cable.  
For internal use of the actuator, use earth screws only.
5. After wiring completed, fix a rubber gasket to the actuator cover firmly to prevent water ingress.
6. While the product operates, follow the instructions below.
  - Keep the product energized constantly because it has a built-in space heater for dew condensation prevention.
  - Do not place hands around the moving parts (connector) while the product operates.
7. Before operating, confirm that wiring and power voltage are correct. Then perform test working to check if the product operates properly.
8. Confirm the product operating conditions.
  - Check that the opening/closing frequency of the valve is within the duty factor of “20% 15 min.”  
Using the product at a duty factor beyond specified may cause deterioration or burnout of the product.
  - The duty factor indicates the ratio of working time to total time of a valve which opens/closes intermittently. “20% 15 min.” indicates that the product is capable of switching opening/closing operation continuously or intermittently for the total of 3 min. (20% of 15 min.) during a 15-minute operation. Frequency of switching opening/closing operation can be calculated from the duty factor.
  - Do not apply reverse rotation signal to the product during its opening/closing operation.  
\*Failure to follow this notice shortens the service life of the product.

## 9. Wiring method

### ■ Wiring diagram

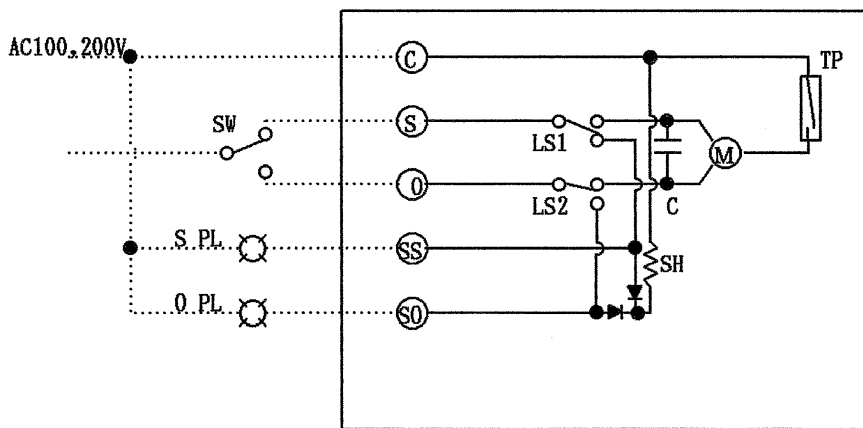

Actuator

..... Wiring has to be done by users.

———— Internal wiring

LS1, LS2: Limit switch

C: Condenser

SH: Space heater

M: Motor

TP Thermal protector

### 5.3 Manual operation

When operating the product manually at the time of power failure or emergency, turn off the power source and follow the instructions below.

- Check direction of the connector and the ball, loosen the screw connecting the body and the actuator, and then, rotate the actuator to the opened or closed position by 90° by hand.
- Before switching to automatic operation, be sure to set the actuator to its original position and fasten it to the body firmly with a screw.
- Wire the actuator to the body with cable cables of long enough for motor rotation of 90° at manual operation.

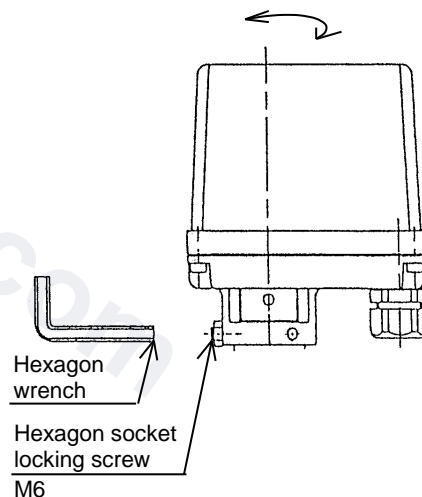

### 5.4 Precaution for maintenance

#### ⚠ Warning

Disassembly and maintenance must be done by experienced professional or valve manufacturer.

1. Confirm that no power is supplied before disassembling or maintenance.

\* Failure to follow this notice may cause an electric shock.

2. Completely discharge the pressure inside of the product, line and equipment before disassembling or maintenance and cool down the product in the case of high-temperature fluid.

\* Failure to follow this notice may result in scalds or injury due to residual pressure.

3. If the product is not used for a long period, check its condition by automatic operation periodically.

4. In the case of excessive humidity is observed inside the actuator cover at the time of maintenance, dry it and eliminate the cause of humidity ingress, and then seal up the cover.

## 5.5 Troubleshooting

Trouble	Cause	How to check	Remedy
Ball (and motor) does not rotate.	1. Fluid pressure exceeds the specified working pressure.	1. Check the fluid pressure with a pressure gauge.	1. Adjust the fluid pressure to the appropriate level.
	2. Ball is stuck with foreign substances.	2. Check the movement while rotating actuator by hand.	2. Please contact us.
	3. Limit switch malfunctions.	3. While rotating actuator by hand, check the continuity between lead wires at the time of valve's opening/closing by using ohmmeter.	3. Replace the actuator with new one.
	4. Power voltage is improper.	4. Check power voltage by using voltmeter.	4. Adjust the power voltage to the appropriate level.
	5. Wiring is wrong		5. Correct the wiring.
	6. Disconnection inside actuator.	6. While rotating actuator by hand, check the continuity between lead wires at the time of valve's opening/closing by using ohmmeter.	6. Replace the actuator with new one.
	7. Loose connection of wiring.	7. Check terminal connections for loose screws.	7. Fasten the screws firmly.
	8. Thermal protector has crack.	8. Check thermal protector for crack, after dismounting actuator cover.	8. Replace the actuator with new one.
	9. Thermal protector malfunctions.	9. Thermal protector actuates when the ambient temperature exceeds 55 °C or when motor generates heat more than rated due to overcurrent.	9. Cool down the thermal protector and eliminate the cause of overcurrent. Then, the thermal protector recovers and operates normally.
Ball (and motor) does not stop rotating.	1. Limit switch malfunctions.	1. While rotating actuator by hand, check the continuity between lead wires at the time of valve's opening/closing by using ohmmeter.	1. Replace the actuator with new one.
	2. Cam has loosened and does not rotate.		2. Replace the actuator with new one.
	3. Wiring is wrong.		3. Correct the wiring.
Other troubles	1. While the opening- closing indicator lamp shows normal condition, ball does not stop at either fully opened or fully closed position.		1. Replace the actuator with new one.
	2. Ball does not rotate while motor runs, because the motor's movement is not conveyed to connector through output shaft.		2. Replace the actuator with new one.

## アフターサービスについて

### 1. 納入品の保証範囲及び保証期間

納入された製品は高度の技術と厳しい品質管理の基で製造いたしております。取扱説明書、本体貼付ラベル等の注意書に従って正しくご使用ください。万一材料または製造上の不具合がありました場合には、無料で修理させていただきます。

納入品の保証期間は、ユーザー様に納入し試運転開始後1ヶ年とさせていただきます。

### 2. 製造中止後の部品の供給について

製品は予告なく製造中止、改良を行うことがございます。製造中止した製品の部品の供給は、中止後5年間とします。但し、個別契約に基づく場合は除きます。

### 3. 保証期間内でも次の場合には、有料修理になります。

(1)配管内のゴミ等による弁漏れ、または不安定作動が起こる場合。

(2)不当な取扱い、または使用による場合。

(3)消耗のはなはだしい部品などで、弊社から予めその旨申し出を行っている場合。

(4)異常水圧、異常水質等の供給側の事情による場合。

(5)水垢もしくは凍結に起因する場合。

(6)電源、空気源に起因する場合。

(7)弊社以外の不適切な改造がされた場合。

(8)設計仕様条件を超えた過酷な環境下(たとえば屋外使用による腐食の場合など)での使用による場合。

(9)火災、水害、地震、落雷その他天災地変による場合。

(10)消耗部品(たとえばテクニカルガイドブックに記載されているリング、ガスケット、ダイヤフラムなど)

ここでいう保証は納入品単体の保証を意味するもので納入品の故障や瑕疵により誘発される損害については、含まれませんのでご了承ください。

### 4. 保証期間経過後、修理を依頼される時

修理により製品の機能が維持できる場合には、ご要望により有料で修理します。なお、アフターサービスについては、弊社ホームページ([www.yoshitake.co.jp](http://www.yoshitake.co.jp))のサポート&サービスからお問い合わせ窓口一覧より最寄りの営業所までご相談ください。