



# MODEL MS-1,2,3,4 Noiseless Heater PRODUCT MANUAL

Thank you very much for choosing the Yoshitake's product. To ensure the correct and safe use of the product, please read this manual before use. This manual shall be kept with care for future references. The symbols used in this manual have the following meanings.

 <b>Warning</b>	This symbol indicates a potentially hazardous situation that, if not avoided, could result in death or serious injury.
 <b>Caution</b>	This symbol indicates a hazardous situation that, if not avoided, may result in minor or moderate injury or may result in only property damage.

---

## Table of Contents

---

1. Specifications.....	1
2. Dimensions and weight .....	1
3. Nominal size selection method .....	2
4. Installation and operation	
4.1 Precautions for installation .....	3
4.2 Example of piping .....	3-4
4.3. Precautions for operation .....	4
Warranty Information	

# YOSHITAKE

## 1. Specifications

Model	MS-1	MS-3-13	MS-2	MS-4-13
Application	Steam			
Pressure range	0.05~0.7MPa		0.1~0.7MPa	
Maximum warning sound temperature limit	60°C		90°C	
Material	Bronze	Stainless Steel	Bronze	Stainless Steel
Connection	JIS Rc screwed			

## 2. Dimensions and weight [MS-1, MS-3-13]

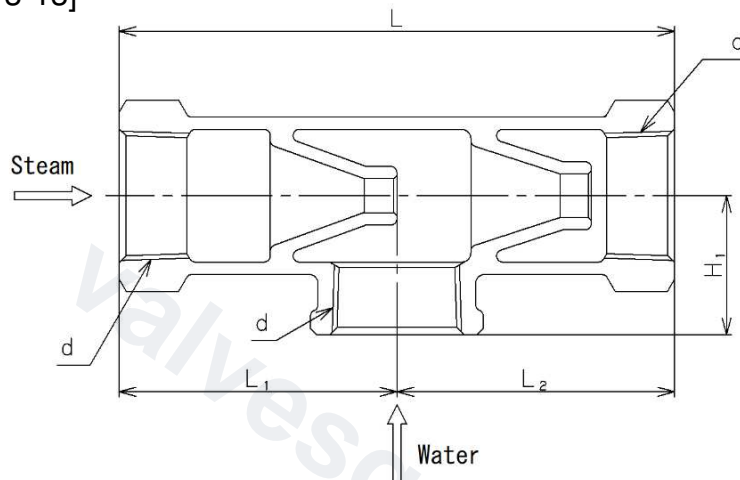

Nominal size	d	L	L <sub>1</sub>	L <sub>2</sub>	H <sub>1</sub>	Weight (kg)
15A	Rc 1/2	100	50	50	25	0.4
20A	Rc 3/4	110	55	55	30	0.4
25A	Rc 1	140	70	70	35	0.8
32A	Rc 1 1/4	180	90	90	45	1.0
40A	Rc 1 1/2	200	100	100	50	2.0
50A	Rc 2	270	130	140	65	4.0

## [MS-2, MS-4-13]

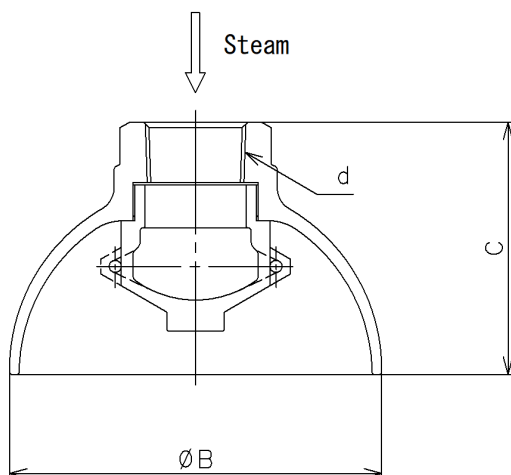

Nominal size	d	C	B	Weight (kg)
15A	Rc 1/2	57	70	0.5 (0.4)
20A	Rc 3/4	71	93	0.8
25A	Rc 1	75	125	1.3 (1.2)
32A	Rc 1 1/4	105	155	3.2 (2.2)
40A	Rc 1 1/2	115	175	4.2 (3.9)
50A	Rc 2	142	220	7.0 (5.4)

\*The above values in parentheses are the weights of MS-4-13

### 3. Nominal size selection method

- Nominal size selection chart

[MS-1, MS-3-13]

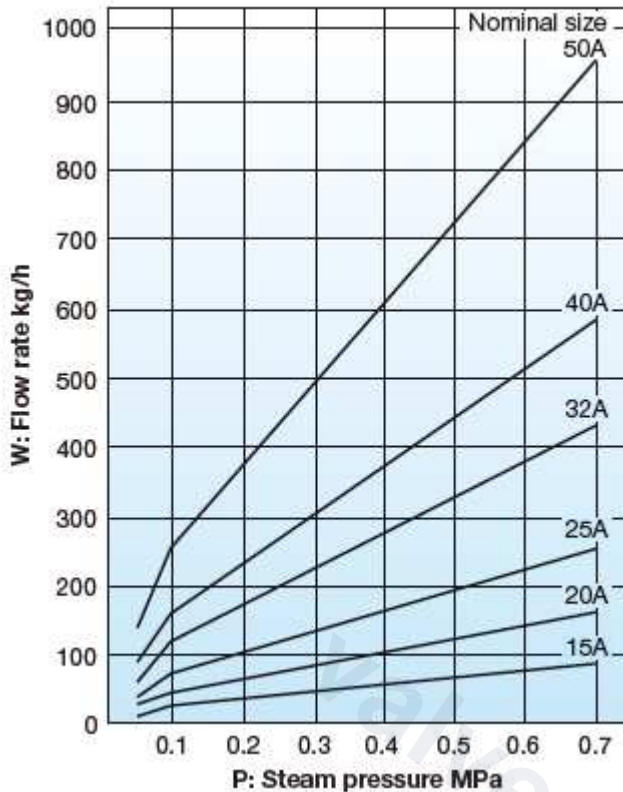

[MS-2, MS-4-13]

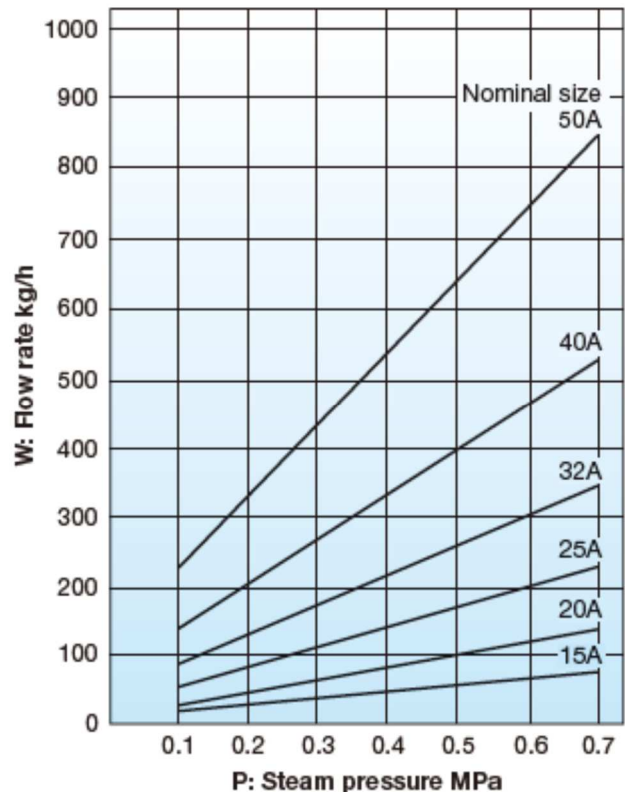

- Formula for calculating the required nominal size

The steam volume “W” required to raise the temperature of “Q” amount of water by “B” degrees Celsius in “A” amount of time is calculated as follows:

$$w = \frac{B \times Q}{500 \times A}$$

W: Steam volume (kg/h)  
 B: Desired temperature rise (°C)  
 Q: Water volume (kg)  
 A: Desired time(h)

Based on the steam volume (W kg/h) and steam pressure (P MPa) values obtained by the above formula, the appropriate nominal size is selected using the “Nominal size selection chart”.

- Nominal size calculation example (MS-2)

When the temperature of 7000kg of water is to be raised from 20 to 60°C over a period of 1 hour, with a steam pressure of 0.5MPa, the nominal size is calculated as follows:

$$w = \frac{(60 - 20) \times 7000}{500 \times 1} = 560(\text{kg/h})$$

Referring to the “Nominal size selection chart”, find the point where the 0.5MPa and the 560 (flow rate) lines intersect. As the point is between the 40A and 50A sizes, the larger size of 50A is selected.

## 4. Installation and operation

### 4.1 Precautions for installation

#### ⚠ Caution

(1) The noiseless heater should be mounted 300mm or more from the tank's walls and bottom. (Refer to 4.2 Example of piping)

\* Vibration may occur in a tank by the flow of a liquid.

(2) Use it within the maximum warning sound temperature limit.

\* Vibration in a tank and piping occurs.

(1) In order to obtain a result as planned, please fully utilize the nominal size selection chart.

(2) There are various methods in attachment and please take into consideration the blow-off position with the size of a tank etc. (Refer to 4.2 Example of piping)

(3) Submerge the product in the tank. If it is unavoidable, keep it as close to the water surface as possible. (Refer to 4.2 Example of piping)

When using the method shown in Fig. 3, make the L dimension as short as possible.

(4) VB-7 vacuum relief valve is recommended in the piping in order to prevent a back-flow condition when the steam is stopped.

### 4.2 Example of piping

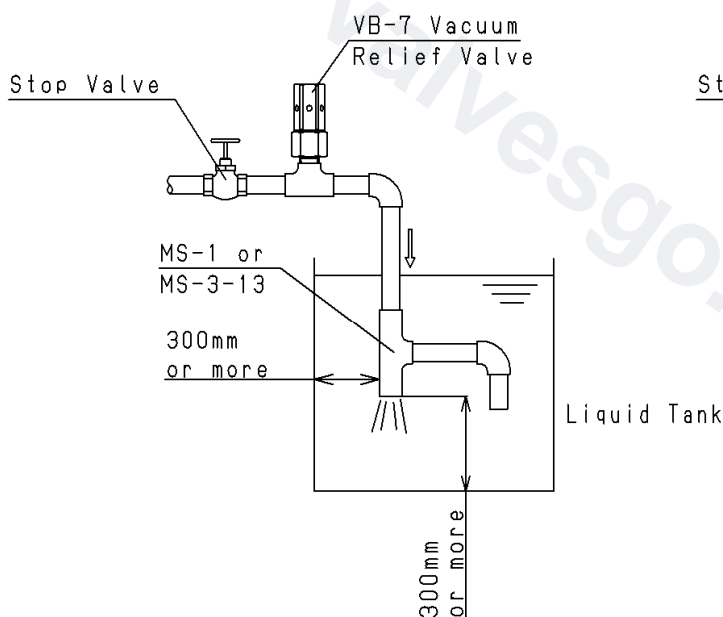

Fig.1

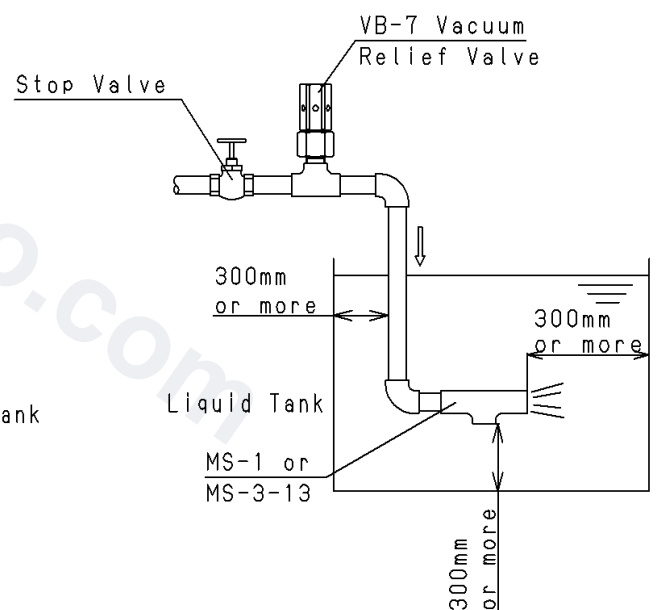

Fig.2

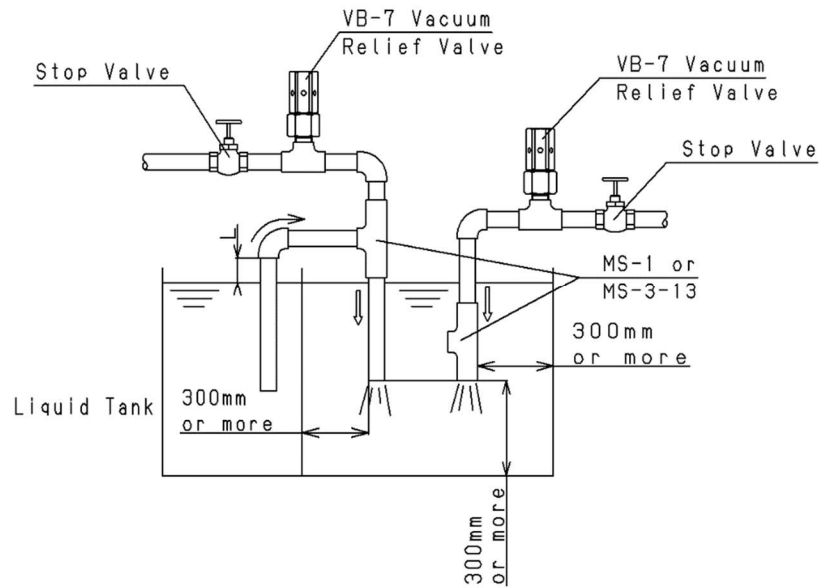

Fig.3

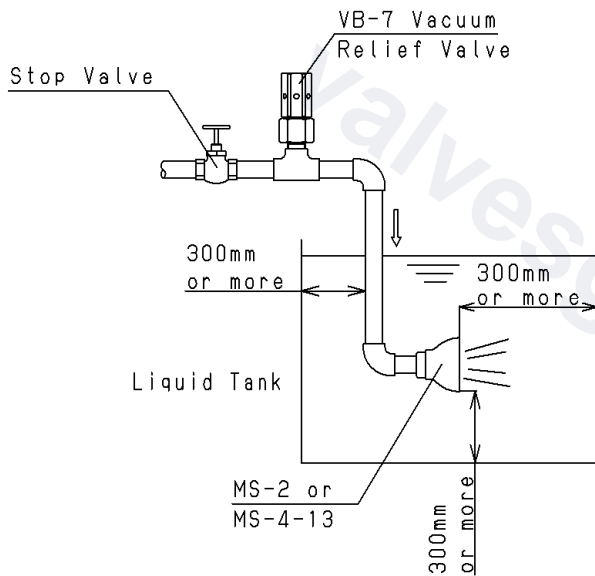

Fig.4

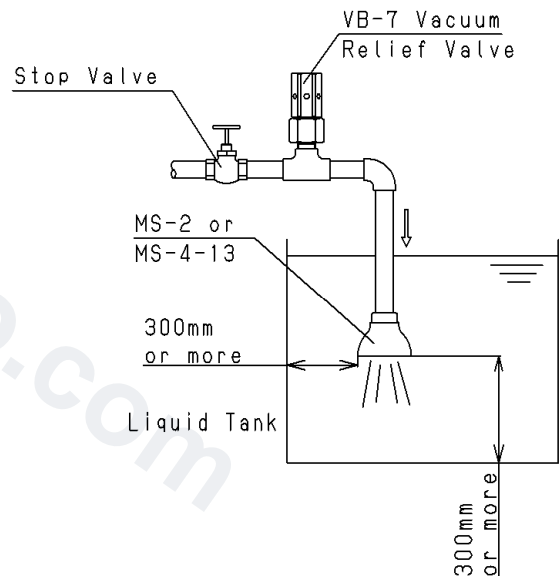

Fig.5

#### 4.3. Precautions for operation

### ⚠ Warning

- (1) Do not touch the product by bare hands
  - \* Failure to follow this notice may cause burn or injury.
- (2) Submerge the product (In the case of Fig. 3, the tip of the pipe) in the water (liquid) in the tank.
  - \* Steam may spout out and result in burns.