

MODEL STC-1 STEAM TRAP CHECKER PRODUCT MANUAL

Thank you very much for choosing the Yoshitake's product. To ensure the correct and safe use of the product, please read this manual before use. This manual shall be kept with care for future references.

The symbols used in this manual have the following meanings. Please note that Chinese language version and Thai language version can be downloaded from the following website.

Website: <http://www.yoshitake.jp/index.html>

本产品的中文安装使用说明书请从以下网址下载「<http://www.yoshitake.jp/cn>」

ถ้าต้องการ ดาวน์โหลดคู่มือของผลิตภัณฑ์ ภาษาไทยให้ ดาวน์โหลดได้ที่「<http://www.yoshitake.jp/th>」



	Warning	This symbol indicates a potentially hazardous situation that, if not avoided, could result in death or serious injury.
	Caution	This symbol indicates a hazardous situation that, if not avoided, may result in minor or moderate injury or may result in only property damage.

Table of Contents

1. Usage of the Product	1
2. Specifications and Mode	1-2
2.1 Specifications	1
2.2 Mode (function)	2
3. Operation procedure	2
4. Dimension and weight	3
5. Before use	3-5
5.1 Precaution for installation	3
5.2 Name of the parts	4-5
5.3 Installing Battery	5
5.4 Peel off protective film of screen	5
5.5 Attach/Remove sensor cap	5
6. How to use	6-11
6.1 Switch operation for Power (ON/OFF) and Mode (function)	6
6.2 Procedures for steam trap automatic diagnosis mode	7-10
6.3 Procedures for surface temperature sensor mode	11
6.4 Procedures for auscultation mode	11
7. Maintenance	12
7.1 Precaution for maintenance	12
7.2 Troubleshooting	12-13
Warranty Information	

YOSHITAKE

1. Usage of the Product

The STC-1 steam trap checker is a simple checker that diagnoses the condition of steam trap, equipped with automatic steam trap diagnosis, operation auscultation, and steam piping surface temperature sensor functions.

2. Specifications and Mode

2.1 Specifications

Model	STC-1
Steam trap automatic diagnosis time	2 seconds or 8 seconds
Working pressure for steam trap automatic diagnosis	0.05-8.0MPa
Working temperature for surface temperature sensing	0-300°C
Automatic power off	After 5 minutes (While steam trap automatic diagnosis mode and not in operation)
Ambient temperature	0-40°C (Non-Freezing)
Where to use	Inside and outside (However, it should not be exposed to rain water).
Battery	DC1.5V AAA alkaline batteries 2pcs Continuous use time: Approximately 8 hours(*1)
Accessories(*2)	Storage case, earphones, AAA alkaline batteries 2pcs(*3)

* 1 When using alkaline batteries (25°C, steam trap diagnosis mode).

* 2 Confirm the package contents before use. If any, please contact us.

* 3 The batteries are not included for overseas shipment (export).

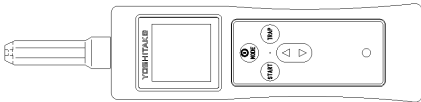
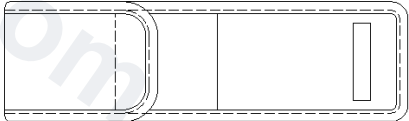
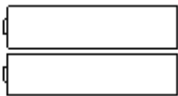
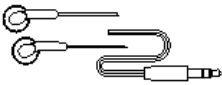
Check	<input type="checkbox"/>	<input type="checkbox"/>
No	(1)	(2)
Name	Steam trap checker	Case
Appearance		
Q'ty	1	1
Check	<input type="checkbox"/>	<input type="checkbox"/>
No	(3)	(4)
Name	AAA alkaline batteries (*3)	Earphones
Appearance		
Q'ty	2	1

⚠ Caution

Check the model on the product label (Please refer to "5.2 Name of the parts") on the product against the model ordered. Also make sure that accessories are stored. If the contents are different, please contact us without using.

2.2 Mode (Function)

Mode(Function)	Overview
Steam trap automatic diagnosis mode	Automatically diagnosis the condition of steam trap(*4)
Surface temperature sensor mode	Indicates the surface temperature of steam piping
Auscultation mode	Listens to the condition of steam trap

*4: Results of steam trap automatic diagnosis

Result	Working condition of steam trap
GOOD	Good condition
CAUTION	Hard to diagnose whether GOOD or LEAK. Caution required for the possibility of LEAK.
LEAK	High possibility of steam leakage
LOW TEMP	High possibility of clogged, not in service, or inadequately low capacity, because the surface temperature is low.

3. Operation procedure

3.1 Steam trap automatic diagnosis mode

The product detects vibration and temperature during steam trap operation, performs automatic diagnosis from the detected data, and displays the result on the screen.

3.2 Surface temperature sensor mode

The product detects the temperature of the steam trap and steam pipe and displays the temperature on the screen.

3.3 Auscultation mode

The product detects vibration during the operation of the steam trap and auscultates the operating condition.

4. Dimension and weight

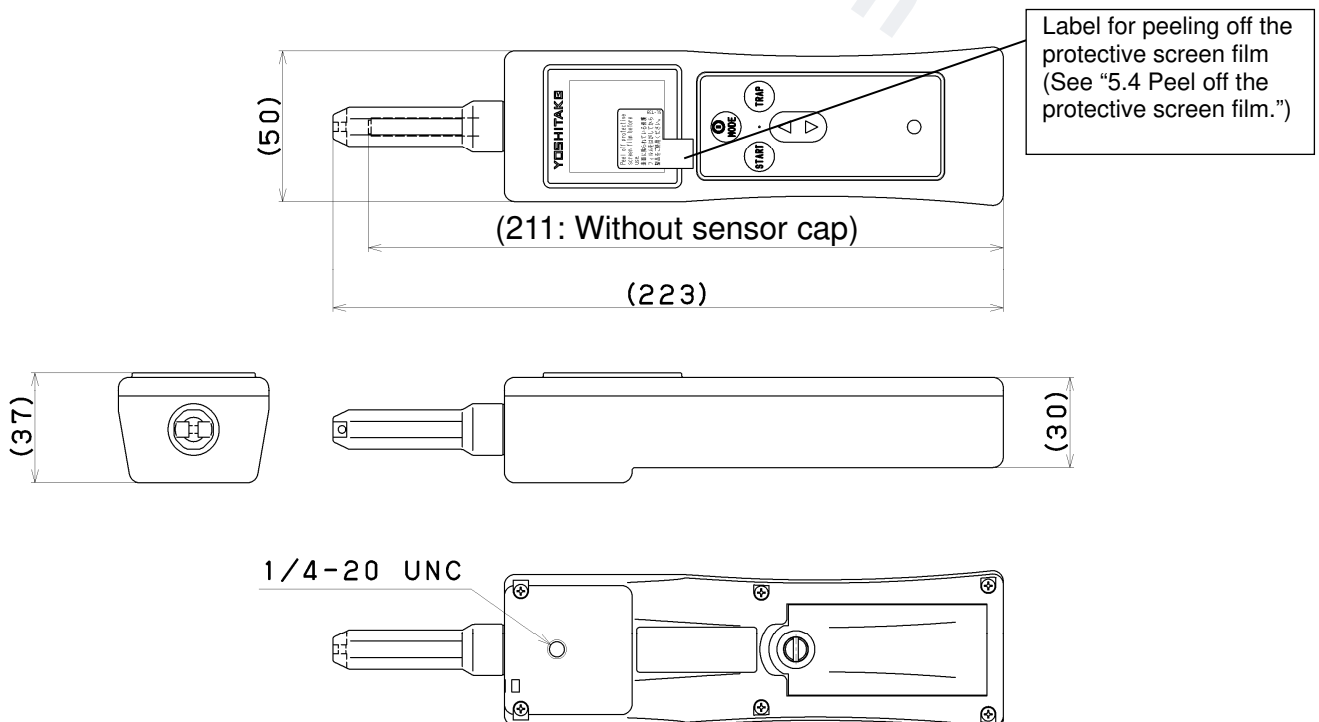

Weight: 214g (including batteries)

5. Before use

5.1 Precaution for installation

Warning

1. The product cannot be used in a place or atmosphere where explosive gas accumulates.
 - * There is a risk of fire because the product is not an explosion-proof structure.
2. If there is a risk of being caught in an equipment, do not use earphone straps.
 - * There is a risk of injury.
3. Do not disassemble or modify the product.
 - * There is a risk of injury, electric shock, or fire.
4. Do not operate the product while walking.
 - * There is a risk of accidents such as falling or collisions.
5. Do not give shock to the product.
 - * There is a risk of injury, electric shock, or fire due to damage or deformation of parts.
6. Avoid from water such as rain.
 - * If water enters, there is a risk of malfunction, heating, electric shock, or fire.
7. Do not mix foreign substances. (Do not use the product in dusty place).
 - * There is a risk of malfunction or fire.
8. Do not leave the product in a place exposed to direct sunlight, in a sun-heated car, or near the fire, where it has the risk of getting high temperature.
 - * There is a risk of battery leakage, heating, rupture, or fire.
9. Do not use the product if the battery has leakage, or if strange odor, deformation, etc. are observed.
 - * There is a risk of heating, fire, or rupture.
 - * If the liquid leaks to your body, immediately rinse with clean water and consult a doctor.

Caution

1. When adopting earphones, work in two people because the surroundings danger cannot be predicted.
2. If the product will not be in used for a long time, remove the batteries and store them in a dry and cool place.
 - * There is a risk of battery leakage, rusting, malfunction or shorter service life.
3. Do not use or store the product near the blow out of steam, salty place, oily place, or in an atmosphere of acid, strong alkali, or organic solvent.
 - * There is a risk of deformation, discoloration, or damage of the product.
4. Make sure that there is no steam or air leakage around the trap to be checked.
 - * Leakage from other than the trap to be checked may cause erroneous diagnosis due to its sound or vibration.

5.2 Name of the parts

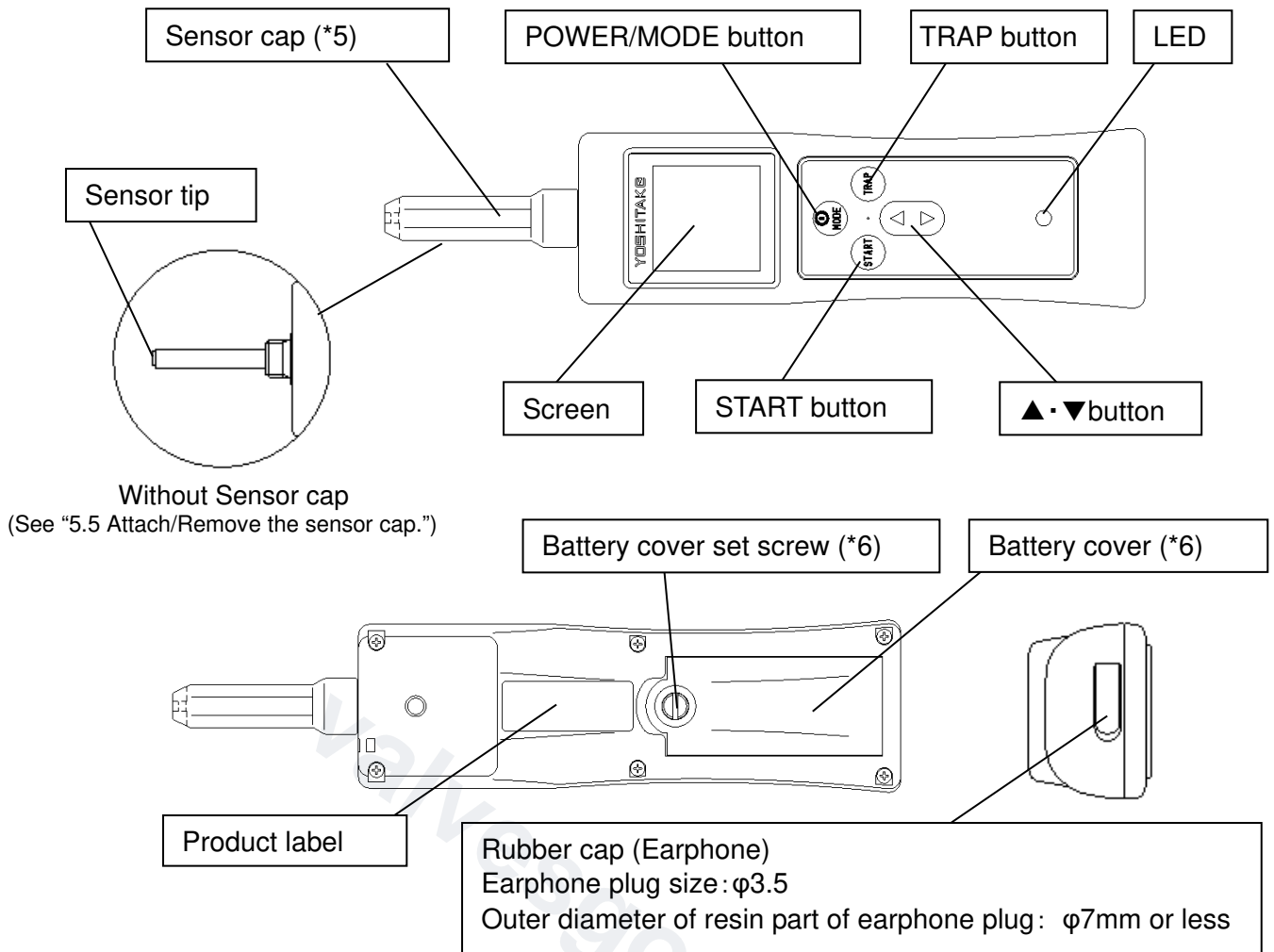

Warning

Do not use the earphones when there is a risk of being caught in an equipment.

Spare parts are available for the parts *5 and *6.

(*6: Battery cover and battery cover set screw are available as a set.)

Manual operation button	Operation description
POWER/MODE button	Power ON/OFF: Press down the button for 2 seconds or more. Switch the mode: Steam trap automatic diagnosis → Surface temperature sensor → Auscultation
TRAP Button	Select a steam trap type.(*7) DISC → BUCKET → FLOAT → THERMO → OTHERS
▲·▼ Button	Select a pressure range. (Available while steam trap automatic diagnosis mode) Adjust Volume. (Available while auscultation mode) Back light ON/OFF: Press down the bottom ▲·▼ for 2 seconds or more. (However, invalid while auscultation mode)
START Button	Start steam trap automatic diagnosis. (Available while steam trap automatic diagnosis mode).

***7: Types of Steam Trap**

Screen Description	Type of steam traps
DISC	Disc type steam trap
BUCKET	Bucket type steam trap
FLOAT	Float type steam trap
THERMO	Thermostatic type steam trap (Bellows, Bi-metal) (*8)
OTHERS	Others (Orifice, Unknown type) (*8)

*8: STC-1 cannot be used to check steam traps for tracing lines.

5.3 Installing battery

- 5.3.1 Loosen the battery cover set screw (Counterclockwise) with a flat-head screwdriver or coin, and remove the battery cover.
- 5.3.2 Install the batteries with the polarity of the battery (accessory) matched.
- 5.3.3 Attach the battery cover and tighten the battery cover set screw with a flat-head screwdriver or coin while holding the battery cover. (Clockwise).

Caution

1. If the product will not be in used for a long time, remove the batteries.
*There is a risk of battery leakage.
2. Do not overtighten the battery cover set screw.
*The case and battery cover will be damaged.

5.4 Peel off protective screen film

Gently peel off the protective film while holding the peel-off label.

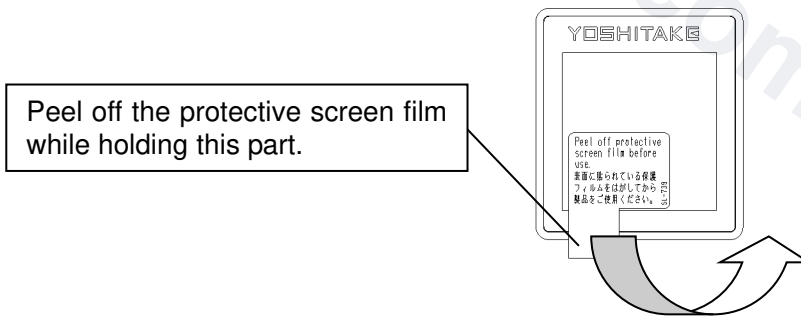

5.5 Attach/Remove sensor cap

- 5.5.1 Loosen the sensor cap by turning it counterclockwise, and remove it
- 5.5.2 To attach the sensor cap, tighten it by turning it clockwise.



6. How to use (Refer to “5.2 Name of the parts”)

6.1 Switch operation for Power (ON/OFF) and Mode (function)

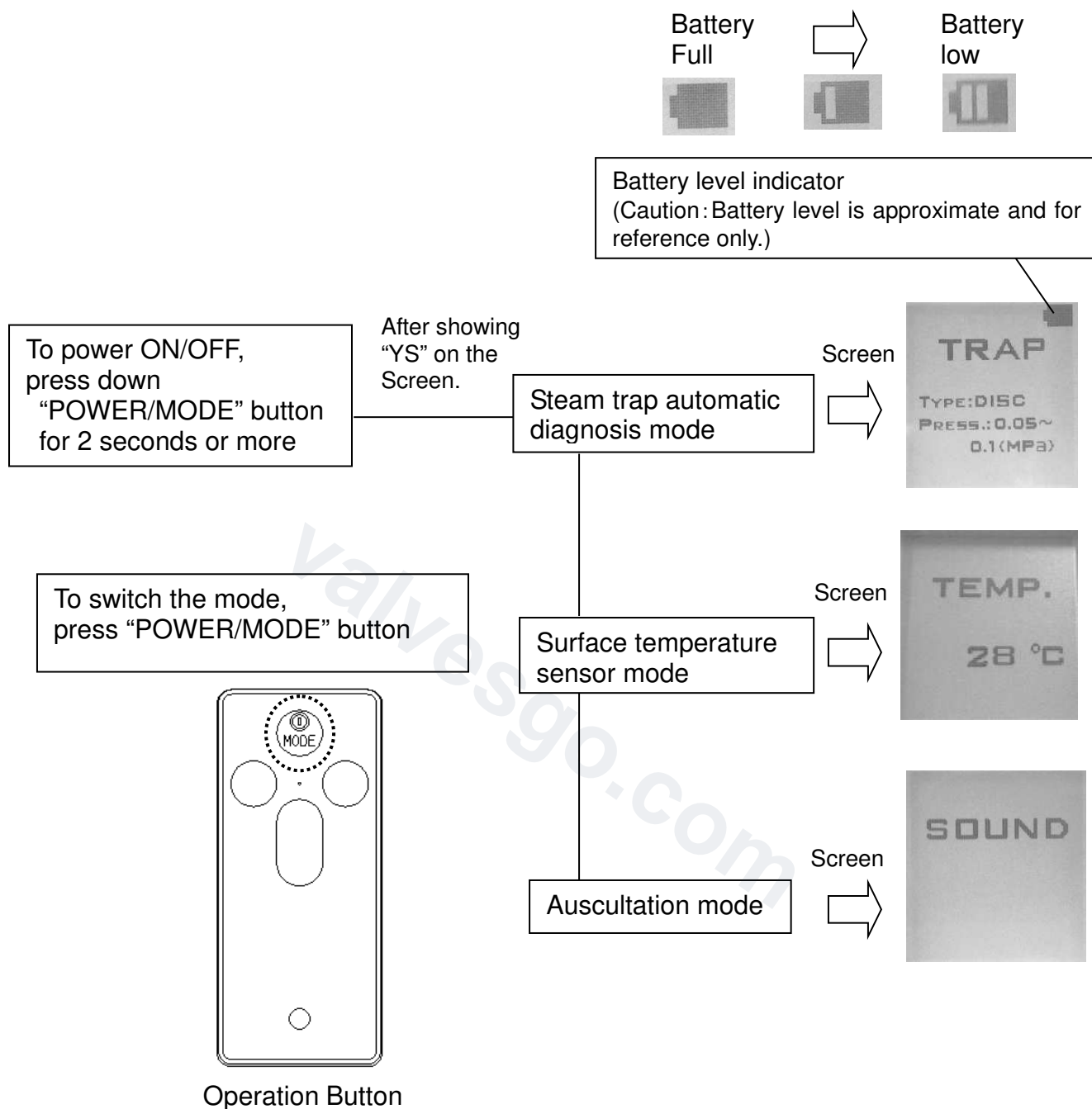

⚠ Caution

1. Do not press the button with a hard object such as metal or resin.
* Button will be damaged.

6.2 Procedures for steam trap automatic diagnosis mode

- 6.2.1 Choose “Steam trap automatic diagnosis mode” by pressing “POWER/MODE” button, according to the procedures shown in 6.1
- 6.2.2 Select the type of steam trap by pressing “TRAP” button.
- 6.2.3 Select the pressure range by pressing “▲・▼” button.

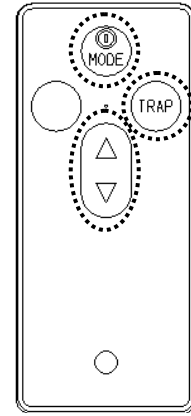

Operation Button



Steam trap automatic diagnosis screen

Switch and select a type of steam trap by pressing “TRAP” button.
 (DISC → BUCKET → FLOAT → THERMO → OTHERS)
 ↑
 Refer to the table “*7: Types of Steam Trap” in “5.2 Name of the parts.”

Switch and select a pressure range by pressing “▲・▼” button.

Table 1: Pressure range

No	Pressure Range
1	0.05 MPa or more and less than 0.1 MPa
2	0.1 MPa or more and less than 0.5 MPa
3	0.5 MPa or more and less than 1.0 MPa
4	1.0 MPa or more and less than 2.0 MPa
5	2.0 MPa or more and less than 3.0 MPa
6	3.0 MPa or more and less than 4.0 MPa
7	4.0 MPa or more and less than 5.0 MPa
8	5.0 MPa or more and less than 6.0 MPa
9	6.0 MPa or more and less than 7.0 MPa
10	7.0 MPa or more and less than 8.0 MPa

6.2.4 Press the sensor tip vertically against the inlet side (flat surface) of the steam trap.

Caution

1. During the steam trap diagnosis, press the sensor tip as vertically as possible.
 - * If the sensor tip is pressed from an angle, the contact condition of the sensor will change and accurate measurement will not be possible. It is recommended to create a flat surface (at least $\phi 6$) by sanding the measurement surface.
2. Measure the steam trap by pressing the sensor tip at the same position.
 - * Diagnosis result will differ depending on the measurement positions.
3. Do not push the sensor too much.
 - * It will lead to damaging the tip.

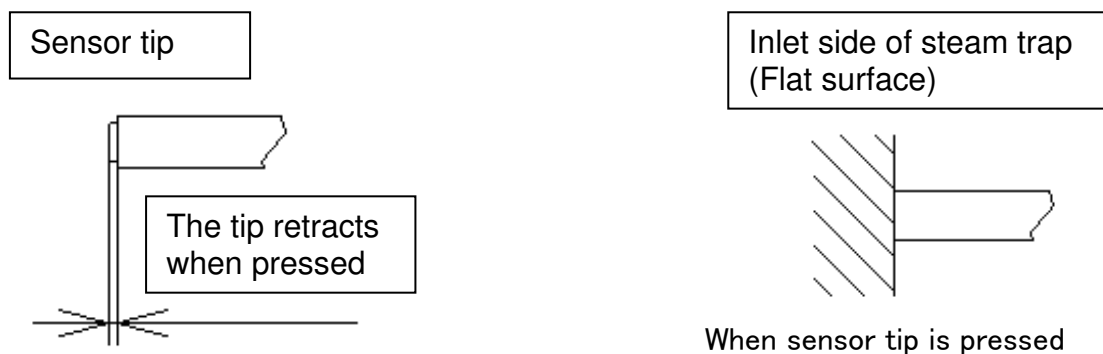
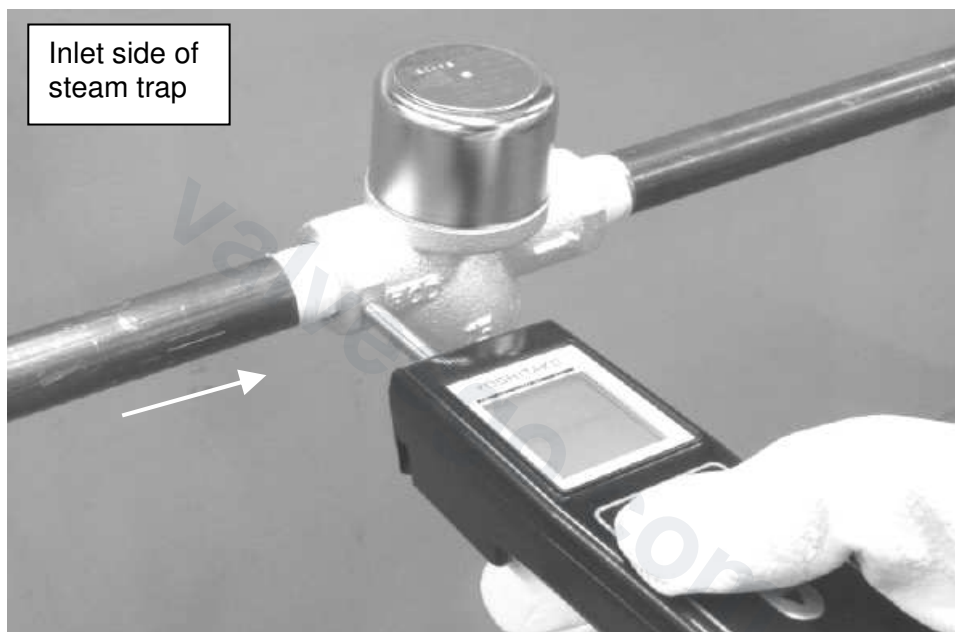

6.2.5 Press “Start” button to start the steam trap diagnosis.
Vibration will notify you of starting of the measurement.

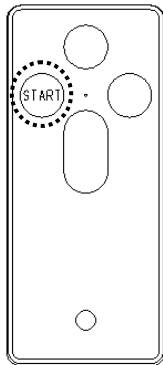

Operation button

Level gauge of measuring time

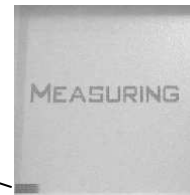

Screen while automatic diagnosis
(2 seconds or 8 seconds)

* Timer function:

Press down “START” button for 2 seconds and then vibrator operates.

After 10 seconds, the diagnosis automatically starts.

Please use this function when you need time to press down the sensor tip on a steam trap in a deep place.



Caution

Please use the sensor as far as it can be confirmed that the sensor tip is pressed vertically against the inlet side (flat surface) of the steam trap.



Screen while preparation
(10 seconds)



Screen while automatic diagnosis
(2 seconds or 8 seconds)

Push the sensor tip vertically against the inlet side (flat surface) of the steam trap until the vibrator operates.
(After 12 seconds to 18 seconds).

* If the tip of the pressed sensor is disconnected, the screen will show “ERROR.”
Please start again with the procedures shown in 6.2.4.



ERROR Screen

6.2.6 Diagnosis completes with vibrator operation. (After 2seconds or 8 seconds)

6.2.7 The screen displays the diagnosis result. (LED turns on for about 5 seconds).

* Please refer to “*4: Results of steam trap automatic diagnosis” for the condition of steam trap diagnosis.

Diagnosis result	GOOD	CAUTION	LEAK	LOW TEMP.
Screen indication				
LED	Green	Yellow	Red	Yellow

6.2.8 If you need to switch the type or pressure range for another diagnosis, press “POWER/MODE” button once. Then the screen displays below.
Please start according to the procedures shown in 6.2.2.

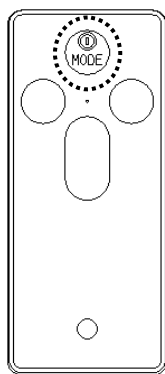

Operation button



Steam trap automatic diagnosis mode screen

6.3 Procedures for surface temperature sensor mode

6.3.1 Choose “Surface temperature sensor mode” by pressing “POWER/MODE” button, according to the procedures shown in 6.1.

6.3.2 Press the sensor tip against the object and measure the temperature. (Refer to 6.2.4.)

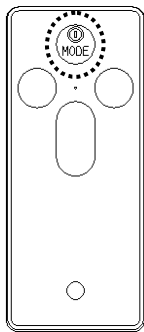

Operation button



Screen while surface temperature sensor mode

6.4 Procedures for Auscultation mode

6.4.1 Choose “Auscultation mode” by pressing “POWER/MODE” button, according to the procedures shown in 6.1.

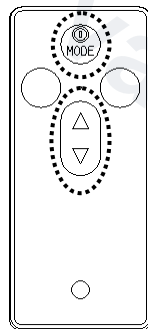

Operation button



Screen while auscultation mode

6.4.2 Open the rubber cap (for earphones) of the product and insert the earphone plug into the earphone jack.

 Warning
Do not use the earphones when there is a risk of being caught in an equipment.

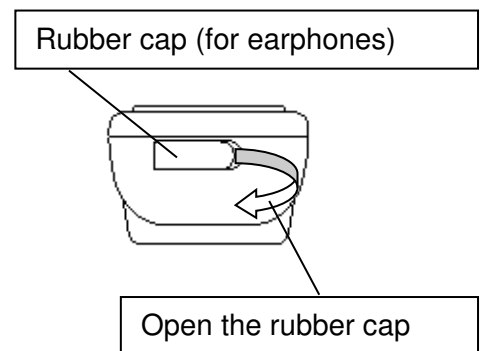

6.4.3 Press the sensor tip against the object and auscultate. (Refer to 6.2.4.)

6.4.4 Adjust the volume by pressing “▲ • ▼” button.

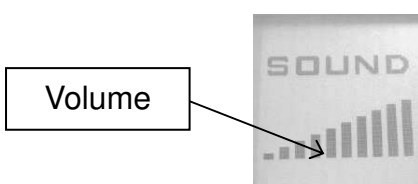

Low volume  High volume

 Caution
Please remove the earphone plug and replace the rubber cap(Push in the rubber cap) after usage.

7. Maintenance

7.1 Precautions for maintenance

 Caution
<p>Do not disassemble the product. * There is a risk of electric shock or fire.</p>

7.2 Troubleshooting

Trouble	Cause	Remedy
No display even after pressing "POWER/MODE" button	No batteries	Install the batteries correctly. Replace the batteries. Refer to "5.3 Installing battery."
	Battery polarity is not correct	
	Low battery	
The measured temperature value is abnormal, while steam trap automatic diagnosis mode or surface temperature sensor mode.	Sensor tip is deformed or damaged.	Need to repair. Please contact us
	Sensor tip is not pressed vertically against the flat surface.	Press the sensor tip vertically against the flat surface. Refer to 6.2.4.
	Foreign matter is attached to the sensor tip.	Be careful not to deform the sensor tip and remove the foreign matter.
Vibrator does not operate.	Not in steam trap automatic diagnosis mode	Switch to steam trap automatic diagnosis mode.
	Low battery	Replace the batteries.
LED does not turn on.	5 seconds or more had passed after diagnosis.	LED turns on within 5 seconds after diagnosis is completed.
	Low battery.	Replace the batteries.
The back lamp does not turn ON/OFF.	Auscultation mode is selected.	Operate in steam trap automatic diagnosis mode or surface temperature sensor mode. Refer to "5.2 Name of the parts" for operation.
Sounds do not come from the earphones.	The earphones are not inserted correctly into the earphone jack.	Insert the earphones correctly. If they cannot be inserted, use the earphones which match to the specifications. Refer to "5.2 Name of the parts"
	The sensor tip is not pressed vertically against the flat surface.	Please push it vertically. Refer to 6.2.4
	Low volume	Adjust the volume of the earphones. Refer to 6.4.

Trouble	Cause	Remedy
Power does not turn OFF automatically even after 5 minutes.	The product is in surface temperature sensor mode or auscultation mode.	Automatic power OFF does not function in surface temperature sensor mode or in auscultation mode. Switch to steam trap automatic diagnosis mode. Refer to 6.1.
Contrast of the screen display changes.	The contrast may change depending on the outside temperature.	This is not malfunction.
Screen flickers or is not displayed. The measured surface temperature value is abnormal	There are electrical effects such as static electricity or electric noise.	Keep away from sources of static electricity or electrical noise. In that case, turn off the power once and turn it on again before use.

*If the problem persist even after taking the above actions, please contact us.

Please note that the contents of this manual are subject to change without prior notice.

valvesgo.com

Warranty Information

1. Limited warranty

This product has been manufactured using highly-advanced techniques and subjected to strict quality control. Please be sure to use the product in accordance with instructions on the manual and the label attached to it.

Yoshitake warrants the product to be free from any defects in material and workmanship under normal usage for a period of one year from the date of receipt by the original user, but no longer than 24 months from the date of shipment from Yoshitake's factory.

2. Parts supply after product discontinuation

This product may be subject to discontinuation or change for improvement without any prior notice. After the discontinuation of the product, Yoshitake supplies the repair parts for 5 years otherwise individually agreed.

3. This warranty does not cover the damage due to any of below:

- (1) Valve seat leakage or malfunction caused by foreign substances inside piping.
- (2) Improper handling or misuse.
- (3) Improper supply conditions such as abnormal water pressure/quality.
- (4) Water scale or freezing.
- (5) Trouble with power/air supply.
- (6) Any alteration made by other than Yoshitake.
- (7) Use under severe conditions deviating from the design specifications (e.g. in case of corrosion due to outdoor use).
- (8) Fire, flood, earthquake, thunder and other natural disasters.
- (9) Consumable parts such as O-ring, gasket, diaphragm and etc.

Yoshitake is not liable for any damage or loss caused by malfunction or defect of the product.

YOSHITAKE

INTERNATIONAL DEPT.

955-5, Miyamae, Irukadeshinden, Komaki, Aichi, 485-0084, Japan

Phone: +81-568-75-4432 Fax: +81-568-75-4763

E-mail: Intntl@yoshitake.co.jp