

MODEL TA-18ML AIR VENT VALVE

PRODUCT MANUAL

Thank you very much for choosing the Yoshitake's product. To ensure the correct and safe use of the product, please read this manual before use. This manual shall be kept with care for future references. The symbols used in this manual have the following meanings.



	Warning	This symbol indicates a potentially hazardous situation that, if not avoided, could result in death or serious injury.
	Caution	This symbol indicates a hazardous situation that, if not avoided, may result in minor or moderate injury or may result in only property damage.

Table of Contents

1. Overview.....	1
2. Specifications and Capacities.....	1
3. Dimension and weight	2
4. Operation	3
5. Maintenance and Inspection.....	4
5.1 Precaution before use.....	4-5
5.2 Precaution for use.....	5
5.3 Piping example.....	5
5.4 Troubleshooting.....	6
5.5 Disassemble	6
6. Exploded view.....	7
After Sales Service	

YOSHITAKE

1. Overview

TA-18ML Air vent valve is compact float type and discharge air automatically from piping. Body material is made of stainless steel, offering high resistance to corrosion and durability. Mainly TA-18ML can be used for water boiler and electrical hot water generator etc.

2. Specifications and Capacities

2 Specifications

Nominal size		6A	10A	15A	20A
Application		Cold and hot water			
Working pressure		0.01-0.3 MPa			
Maximum temperature		100°C			
Material	Body, cover	Stainless steel			
	Disc	FKM (fluororubber)			
	Float	Heat-resistance plastic			
	Guide	Brass			
Connection	Inlet	JIS R1/8	JIS R3/8	JIS R1/2	JIS R3/4
	Outlet	Hose joint $\Phi 6$			

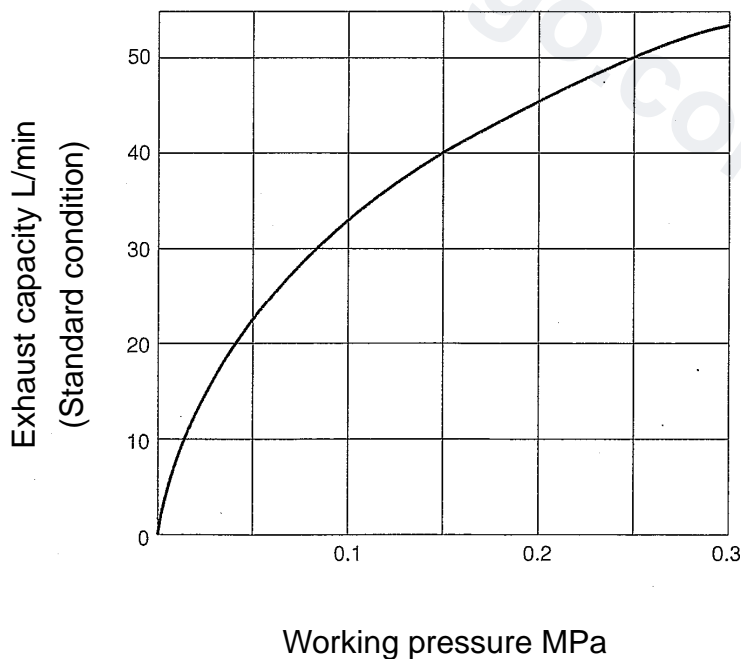

3. Dimensions and Weights

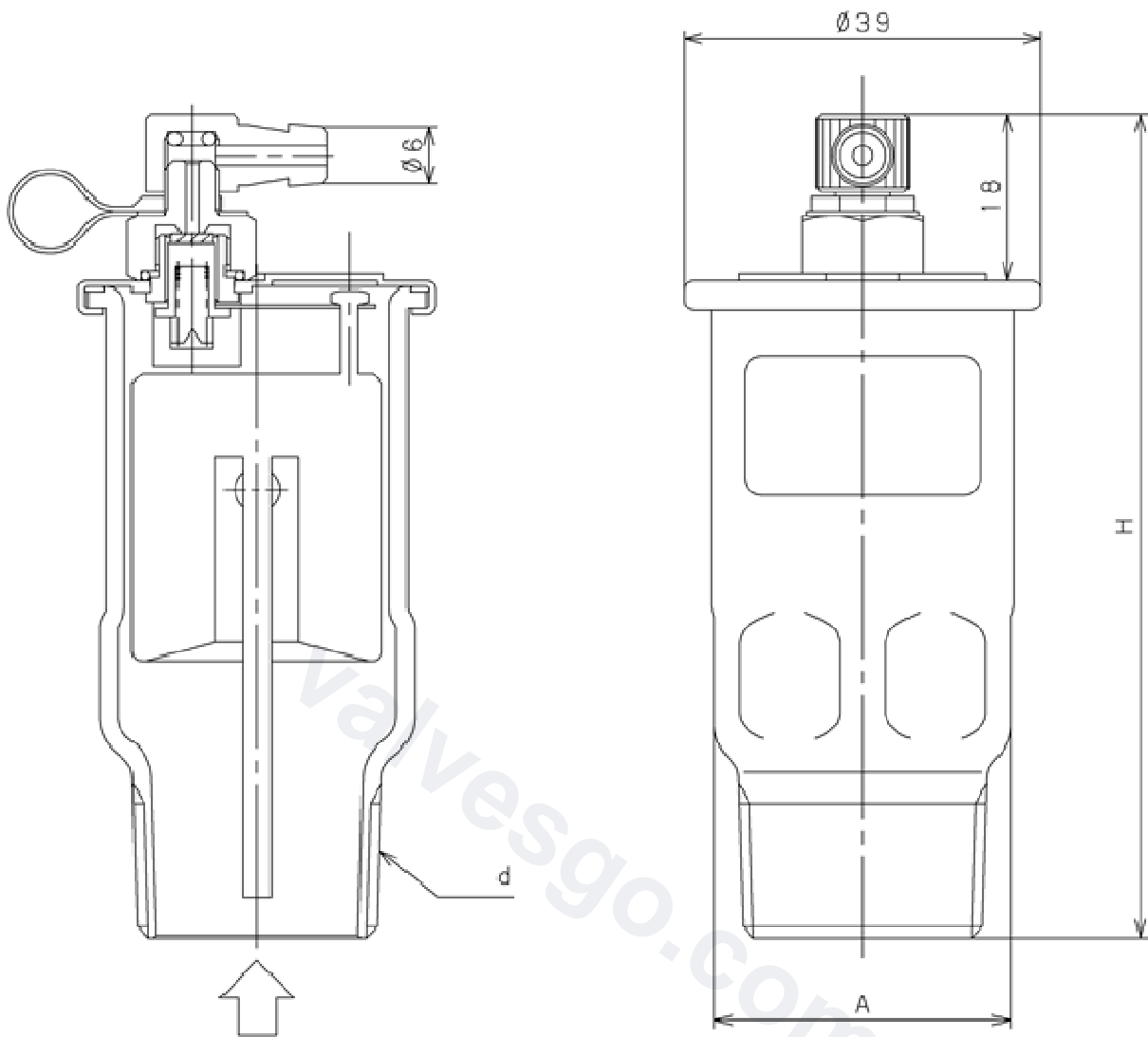

(mm)

Nominal Size	D	H	A (Width across flat)	Weight (kg)
6A	R 1/8	83	-	0.12
10A	R 3/8	87	-	0.13
15A	R 1/2	89	32	0.13
20A	R 3/4	89	32	0.13

4. Operation

1. After the installation, air exists in the product, and the float [10] is lowered by its own weight. In this condition, since the valve disc [6] is kept open by the lever [4], air is discharged outside by the internal pressure of the system.
2. When air is discharged, hot or cold water flows into the product to make the float come up on buoyancy and the force that keeps the valve disc open through the lever is lost. Then the valve disc is closed by the spring [9] and pressure to the valve disc.
3. When air bubbles are generated in the system and collected into the product, the inside water level drops, and the float loses buoyancy and opens the valve disc to discharge air.
4. Repeating the processes 2. and 3., air in the system can be removed.

Structure

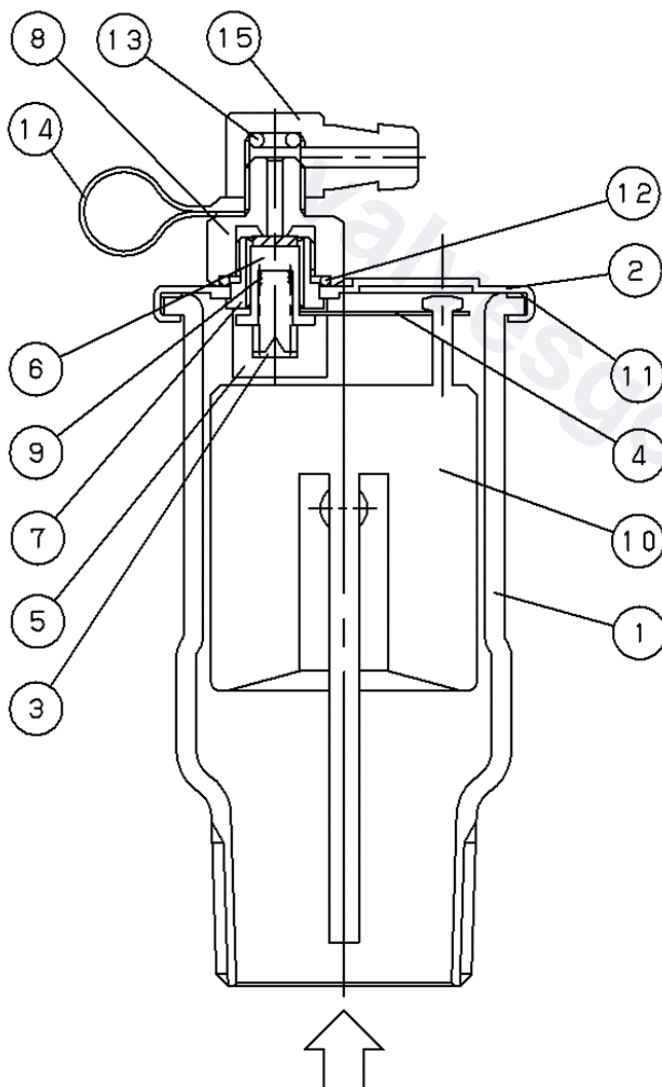

No.	Parts name
1	Body
2	Cover
3	Spring tray
4	Lever
5	Hanger metal
6	Valve disc
7	Guide
8	Valve seat
9	Spring
10	Float
11	O Ring
12	O Ring
13	O Ring
14	Stopper
15	Elbow cap

5. Maintenance and Inspection

5.1 Precaution before use

Caution

1. Make sure to attach joint and hose to outlet of the product, and lead them to drain ditch.
Do not remove the top of the cap stopper [Pic. 2] when operation.
*Fluid leaks because foreign substance exist on valve disc and seat when elbow cap is loosen, leakage of liquid to outside from elbow cap may happen. Do not use the product around the place where leaked liquid can wet another equipment.
*Leakage of liquid result in burns for high-temperature fluid or cause bodily injury or damage to the property when valve leakage happens.

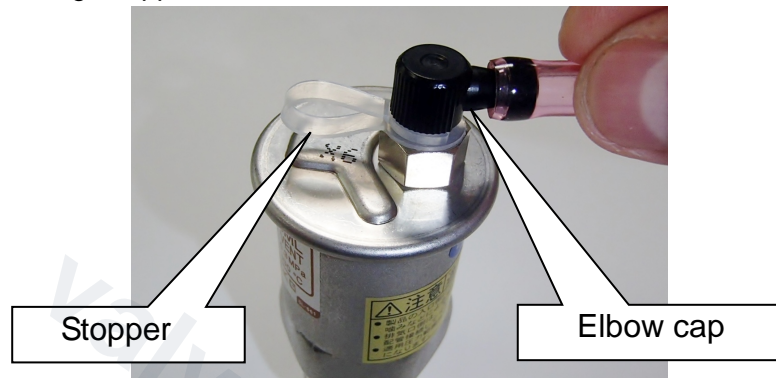

Pic. 1

2. Install the product to a place where check and handle can be done easily in aim of tightening the elbow cap when leakage happens.
*Leakage of liquid result in burns for high-temperature fluid or cause bodily injury or damage to the property when valve leakage happens.
3. Install the product vertically to a place where air is easy to accumulate.
*Failure to follow this notice may prevent the product from functioning properly.
4. Before installing the product, remove foreign substance and scale from the piping.
*Failure to follow this notice may prevent the product from functioning properly.
5. As for nominal size 6A and 10A, tighten the product by hand into piping. As for nominal size 15A and 20A, install the product by proper tool like wrench by hexagonal place on the body. And do not tighten the product excessively.
*Failure to follow this notice may cause deformation of the body and malfunction.

6. Install the product to a place where maintenance and inspection easily.
7. Prevent the product from excess of the pressure e.g. water hammer.
8. When test operation for hot water generator, check there is no leakage by means of inspection of connection and float vent etc.
9. When leakage of liquid happens because of foreign substance like dust on the valve disc and seat, please clean the valve seat (see 5.4 Troubleshooting). As immediate action, remove top pf the cap and tighten the elbow cap to stop the leakage. (Pic.2)
Tighten the elbow cap after removing hose. After tightening please clean valve seat and disc.

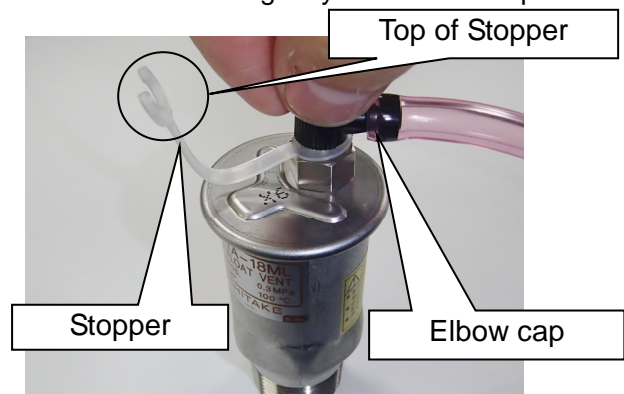

Pic. 2

10. Because elbow cap is made of plastic, it's consumable parts.
11. At brass parts, corrosion can be generated depending on the water quality and it cause malfunction. For the place where corrosion can be expected, select the product made of suitable material like stainless steel.
12. In case ingredient giving negative influence to internal parts is contained in the liquid and environment, deterioration of internal parts can be speeded and it cause leakage and malfunction.
13. In case liquid is accumulated in the product for long-term, moving parts can be sticky and cause malfunction.
14. Nominal size selection chart shows reference value. Suitable size differ according to piping and environment, so around 20% safety factor is necessary for the selection of the size.
15. To avoid potential difference, do to connection different metal parts otherwise corrosion product or parts can happen.

5.2 Precaution for use



Warning

Do not touch the product with bare hands in case of high-temperature fluid.
*Failure to follow this notice may result in burns.



Caution

1. Follow the designated working pressure and Max. temperature.
*Failure to follow this may result in malfunction.
2. When test operation for hot water generator, check there is no leakage by means of inspection of connection and float vent etc.
3. When leakage of liquid happens because of foreign substance like dust on the valve disc and seat, please clean the valve disc and seat (see 5.4 Troubleshooting).

5.3 Piping example

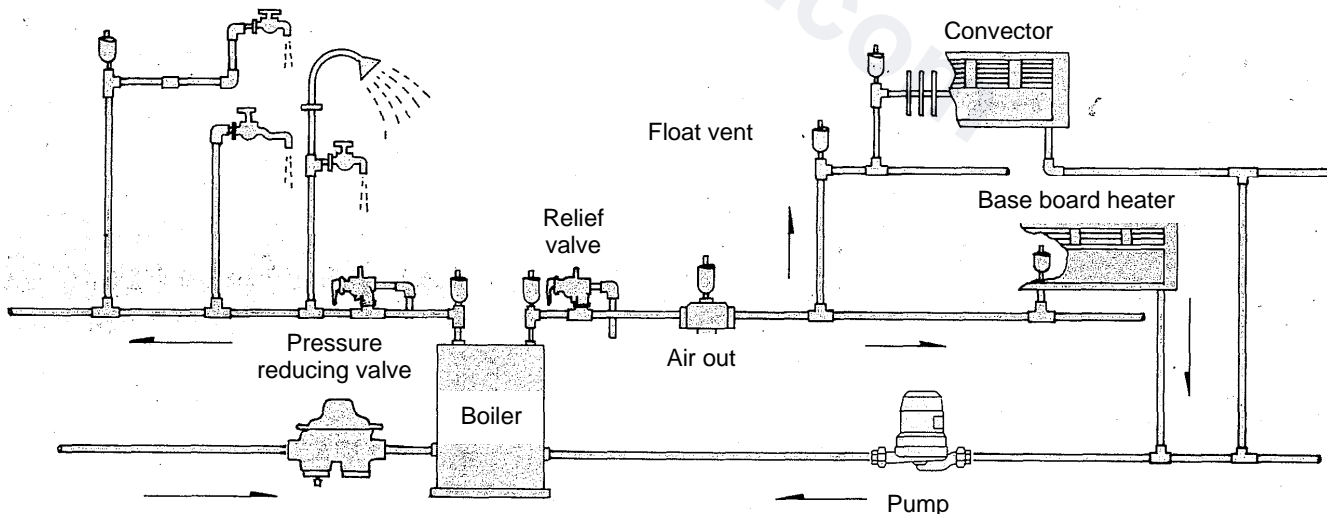



Using this product as a combination with Air Out (Air separator from water) type AO-2, it make efficiency of air discharge higher.

5.4 Troubleshooting

Trouble	Cause	Remedy
Water blowout	1. Foreign substances exist on the valve disc and seat.	1. Remove the valve seat by spanner and clean the scale and dust. After cleaning, fit the O ring (S9) into the ditch on the valve seat and retighten it by spanner.
No air discharge	1. Air accumulates too slowly.	1. Install the valve on a place where air is easy to accumulate.
	2. Internal piping pressure is more than the appropriate value.	2. Lower the internal piping pressure, or replace the valve by one for high pressure.

5.5 Disassemble

 Warning	<ol style="list-style-type: none"> 1. Completely discharge internal pressure of the product, piping and equipment, and cool down the product prior to disassembling or maintenance in case of high-temperature fluid. *Failure to follow this notice may result in scalds or bodily injury due to residual pressure.
--	---

 Caution
<ol style="list-style-type: none"> 1. To maintain function and performance, do regular inspection. *If any problem, please contact well-trained agent. 2. Disassemble must be done by well-trained agent or manufacture. 3. After long-term stop of operation, please inspect operation. *If any problem, please contact well-trained agent.

1. Stop heat resource (Boiler and hot water generator etc.) and pump.
2. Discharge internal pressure in the piping.
3. Remove the valve seat by spanner (12mm). (Pic.3)
4. Remove the valve seat by spanner and clean the scale and dust. (Pic. 4)

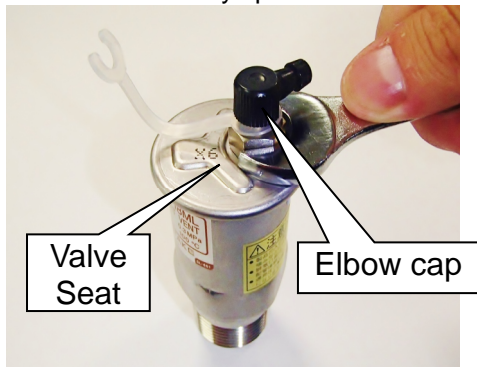

Pic. 3

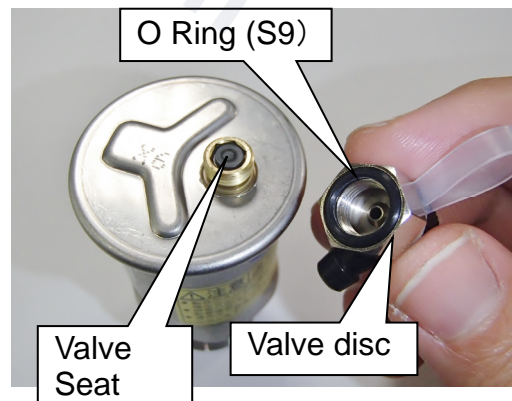

Pic. 4

5. After cleaning, fit the O ring (S9) into the ditch on the valve seat and retighten it by spanner. (Torque: Approx. 3N·m). O Ring and elbow cap are consumable parts.

6. Exploded View

* Because elbow cap is made of plastic, it's consumable parts.

