

MODEL TA-18ML AIR VENT VALVE PRODUCT MANUAL

Thank you very much for choosing the Yoshitake's product. To ensure the correct and safe use of the product, please read this manual before use. This manual shall be kept with care for future references. The symbols used in this manual have the following meanings.



	Warning	This symbol indicates a potentially hazardous situation that, if not avoided, could result in death or serious injury.
	Caution	This symbol indicates a hazardous situation that, if not avoided, may result in minor or moderate injury or may result in only property damage.

Table of Contents

1. Specifications and Capacities	1
2. Dimension and weight.....	2
3. Operational description	3
4. Installation	
4.1 Piping example	4
4.2 Warning and Caution before use.....	4-5
5. Operation	
5.1 Warning and Caution for use	6
6. Maintenance	
6.1 Warning and Caution for maintenance and inspection ..	6
6.2 Daily and Periodic inspection	7
6.3 Troubleshooting	8
6.4 Disassembly	8
6.5 Exploded view	9
After Sales Service	

YOSHITAKE

1. Specifications and Capacities

Nominal size	6A	10A	15A	20A
Application	Cold and hot water			
Working pressure	0.01-0.3 MPa			
Maximum temperature	100°C			
Material	Body, cover	Stainless steel		
	Disc	FKM (fluororubber)		
	Float	Heat-resistance plastic		
	Guide	Brass		
Connection	Inlet	JIS R1/8	JIS R3/8	JIS R1/2
	Outlet	Hose joint $\Phi 6$		

Caution

Please confirm that the indications on the product correspond with the specifications of the ordered product model before use.
*** If they are different, please contact us without using the product.**

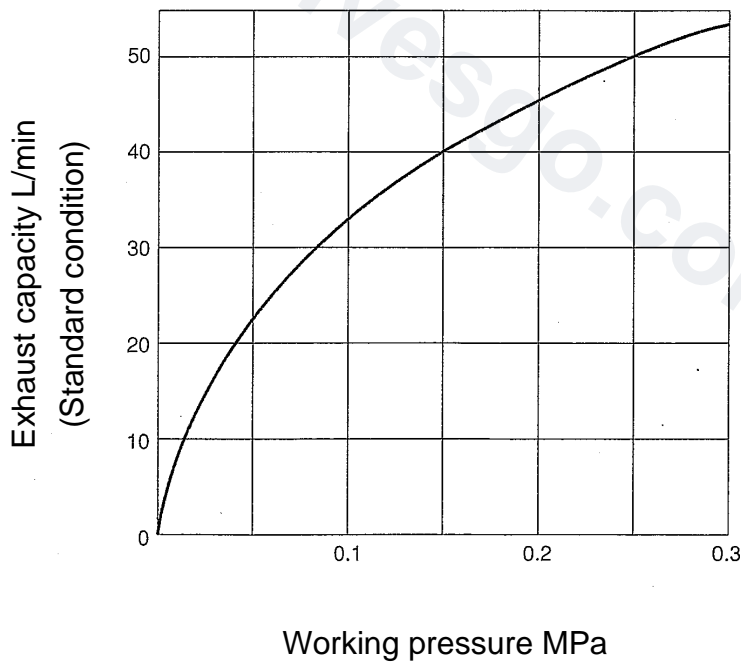

2. Dimensions and Weights

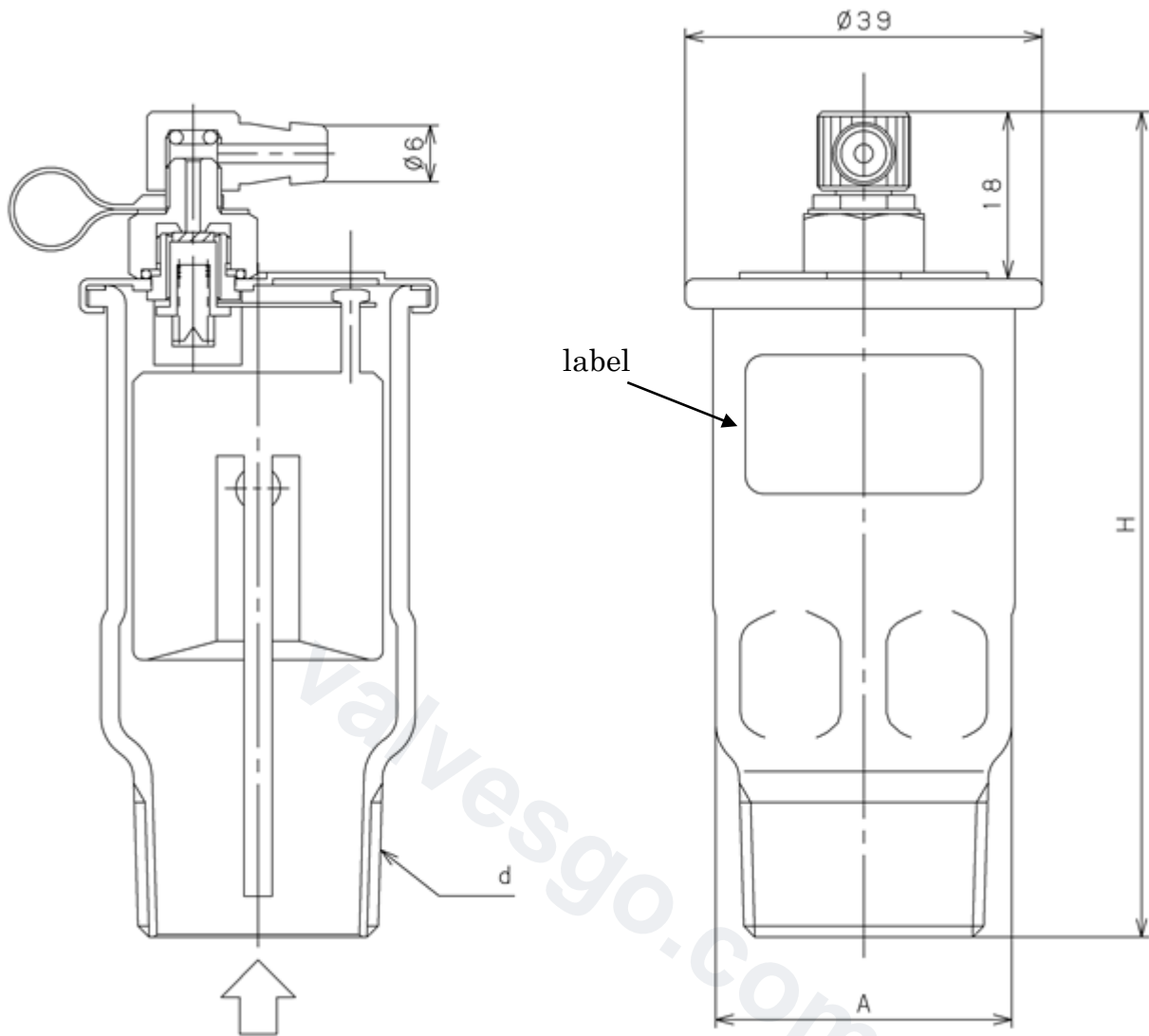

(mm)

Nominal Size	D	H	A (Width across flat)	Weight (kg)
6A	R 1/8	83	-	0.12
10A	R 3/8	87	-	0.13
15A	R 1/2	89	32	0.13
20A	R 3/4	89	32	0.13

3. Operational description

1. After the installation, air exists in the product, and the float [10] is lowered by its own weight. In this condition, since the valve disc [6] is kept open by the lever [4], air is discharged outside by the internal pressure of the system.
2. When air is discharged, hot or cold water flows into the product to make the float come up on buoyancy and the force that keeps the valve disc open through the lever is lost. Then the valve disc is closed by the spring [9] and pressure to the valve disc.
3. When air bubbles are generated in the system and collected into the product, the inside water level drops, and the float loses buoyancy and opens the valve disc to discharge air.
4. Repeating the processes 2. and 3., air in the system can be removed.

Structure

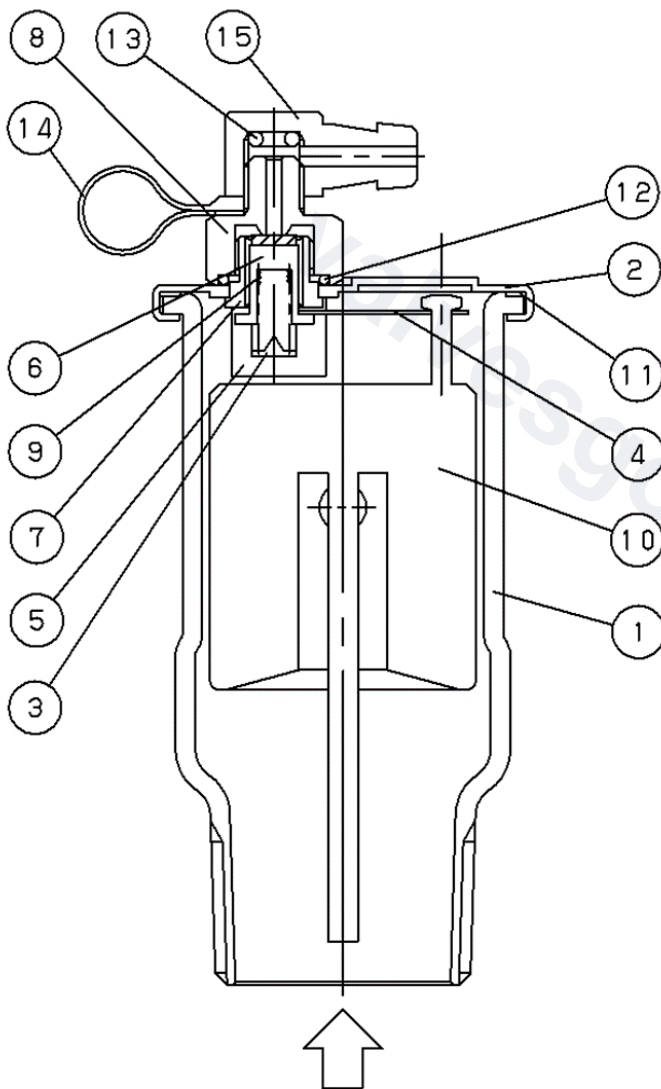

No.	Parts name
1	Body
2	Cover
3	Spring tray
4	Lever
5	Hanger metal
6	Valve disc
7	Guide
8	Valve seat
9	Spring
10	Float
11	O Ring
12	O Ring
13	O Ring
14	Stopper
15	Elbow cap

4. Installation

4.1 Piping example

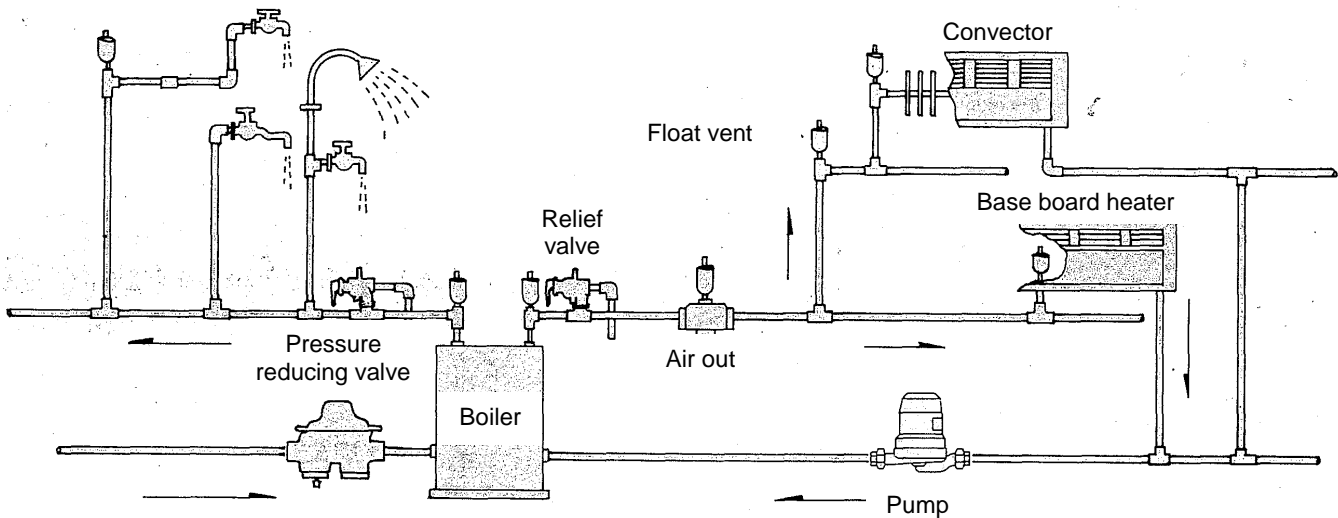

Using this product as a combination with Air Out (Air separator from water) type AO-2, it make efficiency of air discharge higher.

4.2 Warning and Caution before use

⚠ Warning

1. Make sure that end of piping or tube of the product outlet make space of 50mm over from the flood level rim of the vent.
* Failure to follow this notice may contaminate the surroundings, result in burns for high-temperature fluid or cause bodily injury or damage to the property when valve leakage happens.
2. Make sure to attach joint and hose to outlet of the product, and lead them to drain ditch.
Do not remove the top of the cap stopper [Pic. 2] when operation.
*Fluid leaks because foreign substance exist on valve disc and seat when elbow cap is loosen, leakage of liquid to outside from elbow cap may happen. Do not use the product around the place where leaked liquid can wet another equipment.
*Leakage of liquid result in burns for high-temperature fluid or cause bodily injury or damage to the property when valve leakage happens.

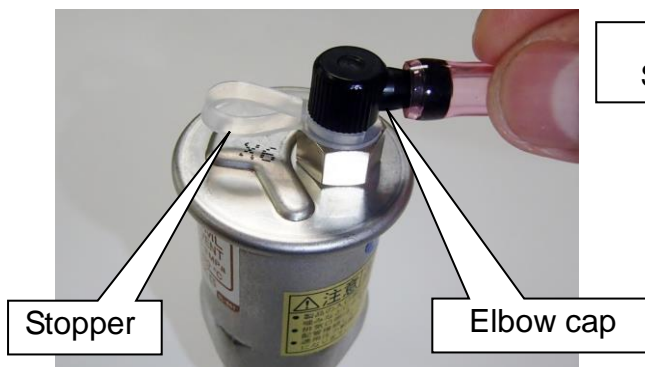

Pic. 1

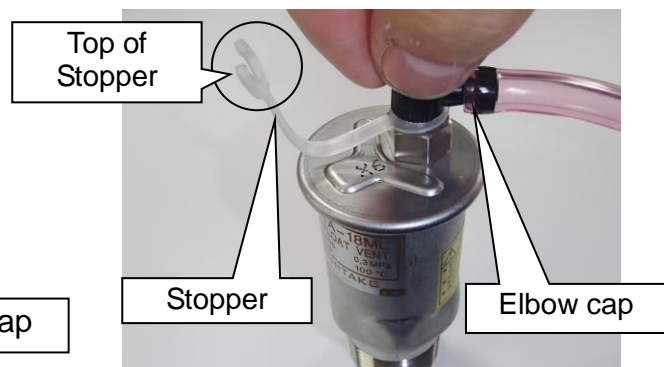

Pic. 2

 Caution

1. Install the product to a place where check and handle can be done easily in aim of tightening the elbow cap when leakage happens.
*Leakage of liquid result in burns for high-temperature fluid or cause bodily injury or damage to the property when valve leakage happens.
2. Install the product vertically to a place where air is easy to accumulate.
*Failure to follow this notice may prevent the product from functioning properly.
3. Before installing the product, remove foreign substance and scale (seal material ect.) from the piping.
*Failure to follow this notice may prevent the product from functioning properly.
4. As for nominal size 6A and 10A, tighten the product by hand into piping. As for nominal size 15A and 20A, install the product by proper tool like wrench by hexagonal place on the body. And do not tighten the product excessively.
Do not tighten more than necessary(15A : 35N·m 20A : 50 N·m).
*Failure to follow this notice may cause deformation of the body and malfunction.
5. Install the product to a place where maintenance and inspection easily.
Prevent the product from excess of the pressure e.g. water hammer.
6. When test operation for hot water generator, check there is no leakage by means of inspection of connection and float vent etc.
7. When leakage of liquid happens because of foreign substance like dust on the valve disc and seat, please clean the valve seat (see 6.3 Troubleshooting). As immediate action, remove top pf the cap and tighten the elbow cap to stop the leakage. (Pic.2)
Tighten the elbow cap after removing hose. After tightening please clean valve seat and disc.
Because elbow cap is made of plastic, it's consumable parts.
The elbow cap will be damaged if it is tightened with excessive force(Tightening torque : 0.5 N · m more).
8. Install the product vertically (tolerance angle 5°) to a place where air is easy to accumulate.
* Failure to follow this notice may prevent the product from functioning properly.
9. If there is a possibility of freezing or the product is not used for an extended period, completely discharge fluid from the product and pipes, and close the stop valve.
* Failure to follow this notice may cause malfunction of the product due to rusting inside the product and the pipes or damaged by freezing.
10. If the piping is under negative pressure, it draw in outside air.
11. Install a stop valve (valve cock or gate valve) at the inlet of the air vent valve for maintenance and inspection.
12. At brass parts, corrosion can be generated depending on the water quality and it cause malfunction.
For the place where corrosion can be expected, select the product made of suitable material like stainless steel.
13. In case ingredient giving negative influence to internal parts is contained in the liquid and environment, deterioration of internal parts can be speeded and it cause leakage and malfunction.
14. In case liquid is accumulated in the product for long-term, moving parts can be sticky and cause malfunction.
15. Nominal size selection chart shows reference value. Suitable size differ according to piping and environment, so around 20% safety factor is necessary for the selection of the size.
16. To avoid potential difference, do to connection different metal parts otherwise corrosion product or parts can happen.

5. Operation

5.1 Warning and Caution for use



Warning

Do not touch the product with bare hands in case of high-temperature fluid.
*Failure to follow this notice may result in burns.



Caution

1. Follow the designated working pressure and Max. temperature.
*Failure to follow this may result in malfunction.
2. If there is a possibility of freezing or the product is not used for an extended period, completely discharge fluid from the product and pipes, and close the stop valve.
* Failure to follow this notice may cause malfunction of the product due to rusting inside the product and the pipes or damaged by freezing.
3. A small amount of water may blow out with air at air discharge for initial operation.
* This is not a failure of the product.
4. If the piping is under negative pressure, it draw in outside air.
5. When test operation for hot water generator, check there is no leakage by means of inspection of connection and float vent etc.
6. When leakage of liquid happens because of foreign substance like dust on the valve disc and seat, please clean the valve disc and seat (see 6.4 Troubleshooting).

6. Maintenance

6.1 Warning and Caution for maintenance and inspection



Warning

1. Completely discharge internal pressure of the product, piping and equipment, and cool down the product prior to disassembling or maintenance in case of high-temperature fluid.
*Failure to follow this notice may result in scalds or bodily injury due to residual pressure.



Caution

1. To maintain function and performance, do regular inspection.
*If any problem, please contact well-trained agent.
2. Disassemble must be done by well-trained agent or manufacture.
3. After long-term stop of operation, please inspect operation.
*If any problem, please contact well-trained agent.

6.2 Daily and Periodic inspection

Please carry out daily and periodic inspections to maintain product functionality and performance.

● Daily inspection (1time/day)

item	How to inspect	actions to be taken
Working state	Make sure the air is venting. (However, the valve is closed when there is no air inside.)	See 6.3 Troubleshooting.
Valve seat leakage	Please check visually.	See 6.3 Troubleshooting.
external leakage	Please check visually.	See 6.3 Troubleshooting.

● Periodic inspection (1time/year)

item	How to inspect	actions to be taken
Valve Disc	Disassemble and check visually.	If scale such as dust to the Valve Disc, clean it. If there is any damage, replace the valve set.
Valve seat O ring	Disassemble and check visually.	If scale such as dust to the Valve seat, clean it. If there is any damage, please replace the product. If the O ring is damaged, replace it.

● Recommended replacement year

Body(Internal parts),Cover,Guide,Valve disc cannot be disassembled.

It is recommended to replace the product every 3 to 5 years after conducting Daily and Periodic inspection.

6.3 Troubleshooting

Trouble	Cause	Remedy
No air discharge	1. It is difficult for air to accumulate.	1. Install it in a place where air tends to accumulate.
	2. Internal piping pressure is more than the appropriate value.	2. Lower the internal piping pressure, or replace the valve by one for high pressure.
	3. Top of cap stopper comes off.	3. Put the cap stopper. [See 4.2 Pic. 1, 2]
Valve seat leakage.	1. Foreign substances exist on the valve disc and seat.	1. Remove and clean the valve disc and seat. [See 6.4 Disassemble]
External leakage	1. Damage or deformation of the body or cover due to abnormal pressure rise.	1. Replace the product.
	2. O ring is damaged.	2. Replace the O ring.

6.4 Disassemble

1. Stop heat resource (Boiler and hot water generator etc.) and pump.
2. Discharge internal pressure in the piping.
3. Remove the valve seat by spanner (12mm). (Pic.3)
4. Remove the valve seat by spanner and clean the scale and dust. (Pic. 4)

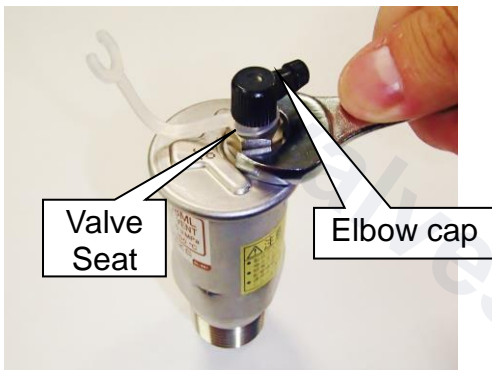

Pic. 3

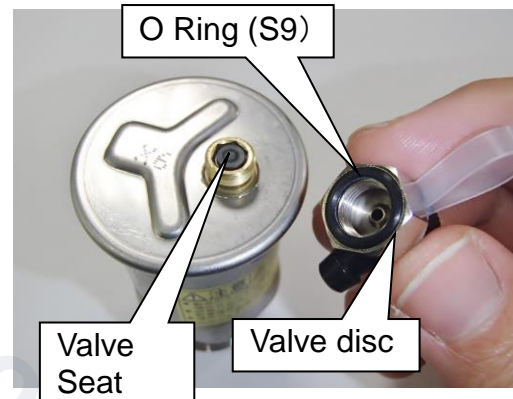

Pic. 4

5. After cleaning, fit the O ring (S9) into the ditch on the valve seat and retighten it by spanner. (Torque: Approx. 3N·m). O Ring and elbow cap are consumable parts.

6.5 Exploded view

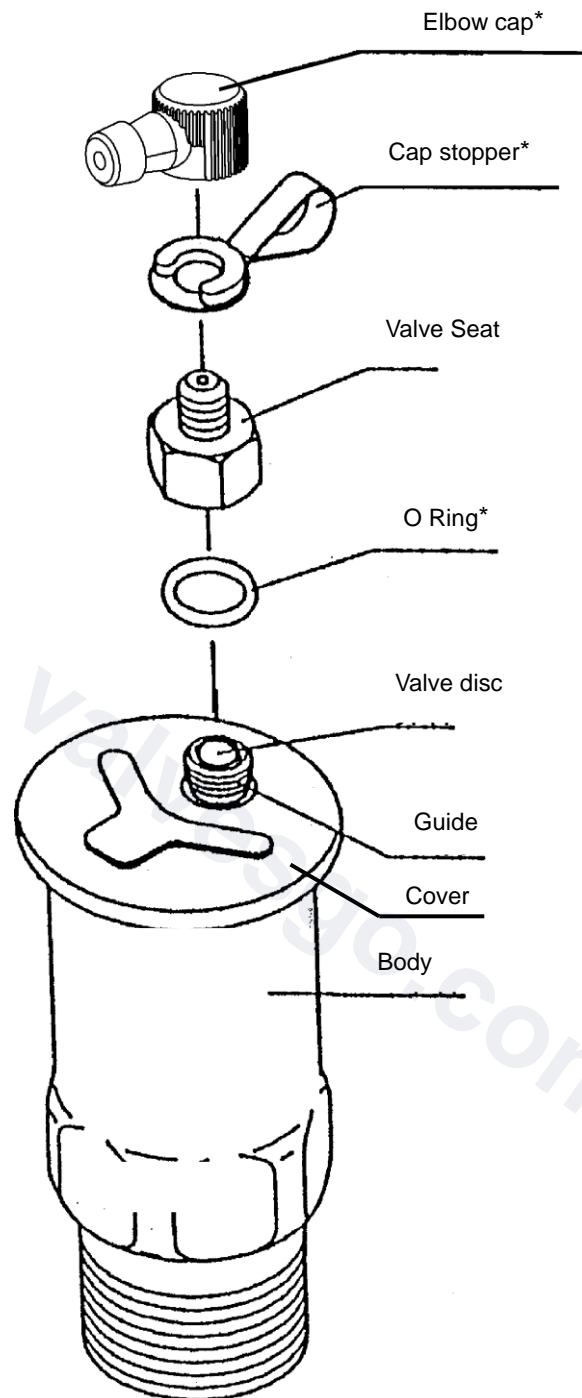

Parts marked with an asterisk (*) are consumable parts.



Caution

Cover cannot be removed.

*If removed, the function and performance of the product cannot be maintained.

Warranty Information

1. Limited warranty

This product has been manufactured using highly-advanced techniques and subjected to strict quality control. Please be sure to use the product in accordance with instructions on the manual and the label attached to it.

Yoshitake warrants the product to be free from any defects in material and workmanship under normal usage for a period of one year from the date of receipt by the original user, but no longer than 24 months from the date of shipment from Yoshitake's factory.

2. Parts supply after product discontinuation

This product may be subject to discontinuation or change for improvement without any prior notice. After the discontinuation of the product, Yoshitake supplies the repair parts for 5 years otherwise individually agreed.

3. This warranty does not cover the damage due to any of below:

- (1) Valve seat leakage or malfunction caused by foreign substances inside piping.
- (2) Improper handling or misuse.
- (3) Improper supply conditions such as abnormal water pressure/quality.
- (4) Water scale or freezing.
- (5) Trouble with power/air supply.
- (6) Any alteration made by other than Yoshitake.
- (7) Use under severe conditions deviating from the design specifications (e.g. in case of corrosion due to outdoor use).
- (8) Fire, flood, earthquake, thunder and other natural disasters.
- (9) Consumable parts such as O-ring, gasket, diaphragm and etc.

Yoshitake is not liable for any damage or loss caused by malfunction or defect of the product.

YOSHITAKE

INTERNATIONAL DEPT.

955-5, Miyamae, Irukadeshinden, Komaki, Aichi, 485-0084, Japan

Phone: +81-568-75-4432 Fax: +81-568-75-4763

E-mail: Intntl@yoshitake.co.jp