

Model TA-2·2C·5·5F

Air Vent Valve

INSTRUCTION MANUAL

Thank you very much for choosing the Yoshitake's product. To ensure the correct and safe use of the product, please read this manual before use. This manual shall be kept with care for future references.

The symbols used in this manual have the following meanings.



| | | |
|---|----------------|---|
|  | Warning | This symbol indicates a potentially hazardous situation that, if not avoided, could result in death or serious injury. |
|  | Caution | This symbol indicates a hazardous situation that, if not avoided, may result in minor or moderate injury or may result in only property damage. |

Table of Contents

| | |
|---|---|
| 1. Usage of the Product | 1 |
| 2. Features | 1 |
| 3. Specifications and Performance | 1 |
| 4. Dimensions and Weights | 2 |
| 5. Operation | 3 |
| 6. Maintenance | 4 |
| 6.1 Precautions for operation | 4 |
| 6.2 Precaution for use | 4 |
| 6.3 Troubleshooting | 4 |
| 7. Disassembly | 4 |
| 7.1 Precaution for maintenance | 4 |
| 7.2 Disassembly procedure | 5 |
| 8. Exploded view | 5 |
| Warranty Information | |

YOSHITAKE

1. Usage of the Product

Air vent valve is essential for air conditioning system. Ingress of air into the piping system causes decrease of heat efficiency, noise generation or corrosion of devices, etc. Air vent valves TA-2, 2C, 5, 5F equip quick exhaust mechanism and can greatly reduce time required for water supply since they can exhaust much air inside piping at the time of initial water supply more quickly than conventional air vent valves.

2. Features

1. Equipped with a quick exhaust mechanism, air inside piping can be quickly exhausted at the time of initial water supply, ensuring smooth water supply.
2. Wide pressure range than that of conventional air vent valves and applicable to from low pressure to high.
3. Parts are easy to replace, maintain and inspect from outside even if the valve seat surface is damaged in long period operation.
4. TA-2C has superior corrosion resistance since inside and outside of its body are coated by Nylon 11.
5. Since the body of the TA-5 and TA-5F is made of bronze, these models are free from rusty water.

3. Specifications and Performance

| Model | TA-2 | TA-2C | |
|---|---|--------------------------------|--|
| Application | Cold and hot water, Oil (specific gravity: 0.8 or more) | | |
| Working pressure | 0.01 - 1.0 MPa | | |
| Operating pressure range of quick exhaust valve | 0.01 MPa or less | | |
| Maximum temperature | 90°C | 60°C | |
| Material | Body | Ductile cast iron | |
| | Cover | Bronze | |
| | Valve | Brass | |
| | Floating valve | Brass (Equipped with NBR disc) | |
| | Float | Stainless steel | |
| Connection | JIS Rc screwed | | |

Body is electro deposition coated for rust prevention (TA-2).

Maximum temperature for intermittent usage is 90°C (TA-2C).

Insulation should be done when temperature difference between the product and outside atmosphere is 40°C or more (TA-2C).

| Model | TA-5 | TA-5F | |
|---|---|--------------------------------|--------------------------------|
| Application | Cold and hot water, Oil (specific gravity: 0.8 or more) | | |
| Working pressure | 0.01 - 1.0 MPa | | |
| Operating pressure range of quick exhaust valve | 0.01 MPa or less | | |
| Maximum temperature | 90°C | 120°C | |
| Material | Body | Bronze | |
| | Cover | Bronze | |
| | Valve | Brass | |
| | Floating valve | Brass (Equipped with NBR disc) | Brass (Equipped with FKM disc) |
| | Float | Stainless steel | |
| Connection | JIS Rc screwed | | |



Caution

Please confirm that the indications on the product correspond with the specifications of the ordered product model before use.

* If they are different, please contact us without using the product.

■ Exhaust capacity charts

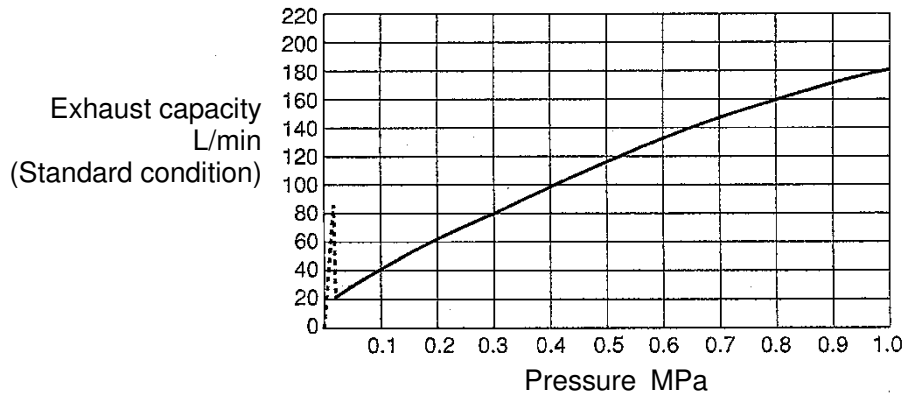

Working range of quick
exhaust valve

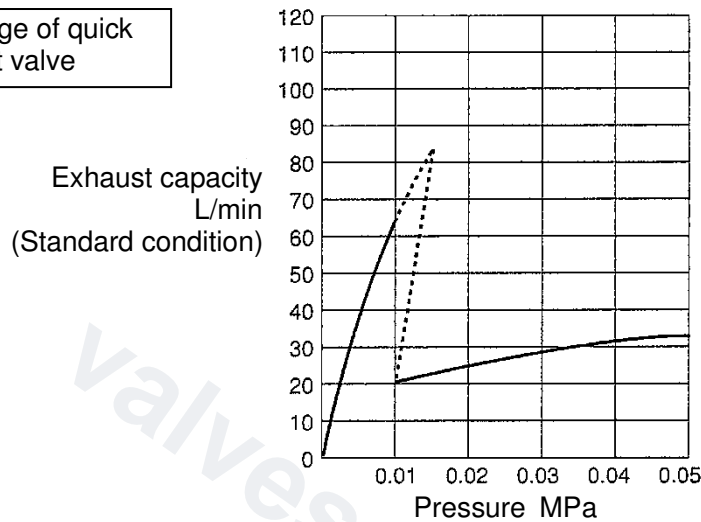

4. Dimensions and Weights

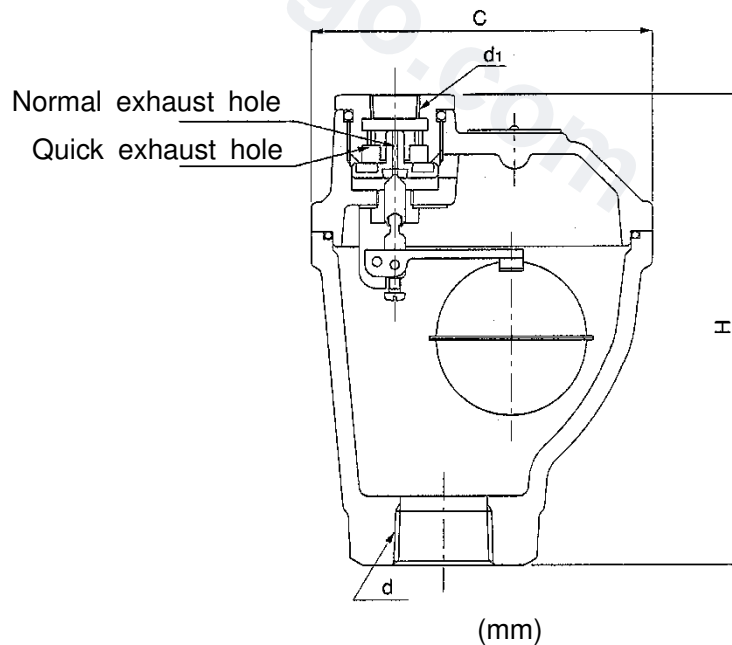

| Nominal size | d | d ₁ | H | C | *Weight (kg) |
|--------------|----------|----------------|-----|-----|--------------|
| 15A | Rc 1/2 | Rc 3/8 | 153 | 114 | 3.18 |
| 20A | Rc 3/4 | Rc 3/8 | 153 | 114 | 3.18 |
| 25A | Rc 1 | Rc 3/8 | 157 | 114 | 3.22 |
| 32A | Rc 1 1/4 | Rc 3/8 | 157 | 114 | 3.22 |

*The weight is for TA-2 · 2C.

5. Operation

- (1) Before water flowing, the float [7] is in low position and the floating valve [2] is opened. 【Fig. 4-1】
- (2) When water starts to flow into the valve, air inside piping is pushed by water and exhausted out through quick exhaust hole. 【Fig. 4-2】
- (3) The float [7] is pushed up by water flowing into the product, and the valve [3] connected with the float is closed. 【Fig. 4-3】
- (4) When air flows into the product, the float [7] is lowered immediately, and at the same time the valve [3] is lowered, and therefore air is exhausted out through quick air vent hole. 【Fig. 4-4】

■ Operation

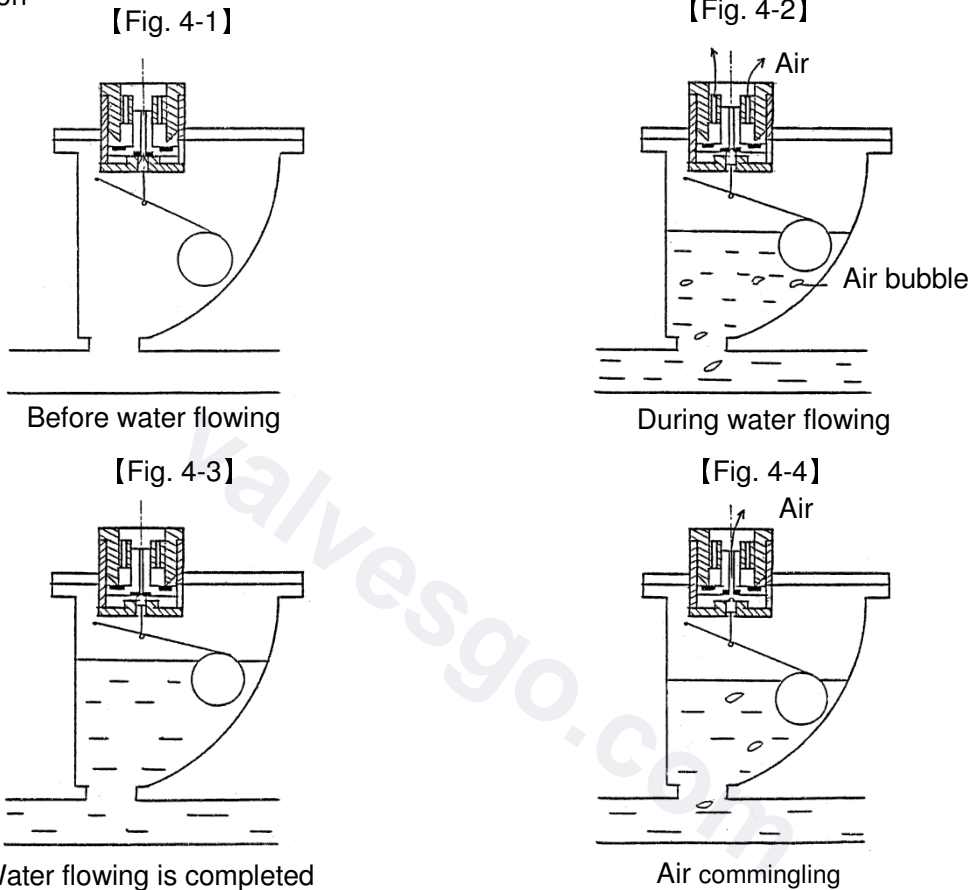

■ Structure

Normal exhaust hole Quick exhaust hole

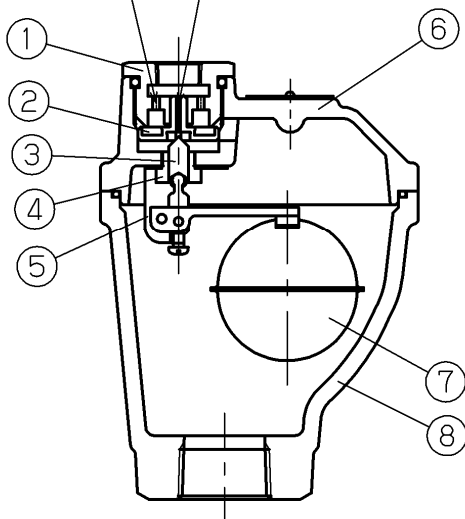

| No. | Parts name |
|-----|----------------|
| 1 | Valve seat |
| 2 | Floating valve |
| 3 | Valve |
| 4 | Valve guide |
| 5 | Hanger |
| 6 | Cover |
| 7 | Float |
| 8 | Body |

6. Operating Procedure

5.1 Precautions for operation

⚠ Caution

1. Install the product perpendicularly on such a place where air likely gathers.
*Failure to follow this notice does not achieve function of the product.
2. Before installing the product, remove foreign substances and scale from the piping.
* Failure to follow this notice may prevent the product from functioning properly due to ingress of foreign substance and scale into the product.
3. When installing the product to piping, tighten the hexagonal part of the body with wrench. Do not tighten it beyond necessity.
*Failure to follow this notice transforms the body and cause malfunction.
4. Lead outlet side of the product to safety place in case water leaks.
*Failure to follow this notice may contaminate surroundings.

1. Install stop valve (cock or gate valve) at inlet side of the product for maintenance and inspection.
2. There is a possibility of leakage by scale inside piping. Install the point of outlet side so that back flow to drain ditch cannot happen as shown in the right figure

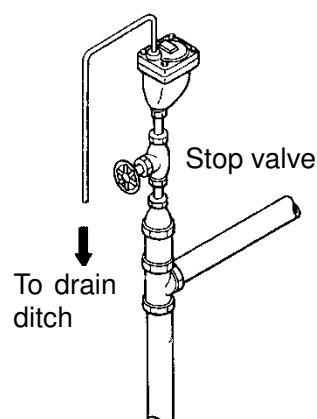

6.2 Precaution for use

⚠ Warning

1. Do not touch the product directly with bare hand in case of high temperature fluid.
* Failure to follow this notice may cause burns.

6.3 Troubleshooting

| Trouble | Cause | Remedy |
|--------------------------|---|--|
| Air cannot be exhausted. | 1. Stop valve at inlet side has been closed. | 1. Open the stop valve fully. |
| | 2. Piping pressure is above the optimum level. | 2. Reduce the piping pressure or replace the product with the model for high pressure. |
| Water outflows. | 1. Floating valve [2] is stuck by foreign substance | 1. Disassemble the product and clean floating valve. |
| | 2. Floating valve [2] is damaged. | 2. Replace floating valve [2]. |
| | 3. Float [6] is damaged and loses the specified function. | 3. Replace float [7]. |

7. Disassembly

7.1 Warning for maintenance



Warning

Completely discharge the pressure inside of the product and piping before disassembly or maintenance.
* Failure to follow this notice may result in injury due to residual pressure.

7.2 Disassembly procedure

- (1) Remove the valve seat by using a spanner (width across flat: 36 mm).
- (2) Remove the O ring (P-28)
- (3) Remove the floating valve.
- (4) Remove the clamping bolt (M10) of the cover.
- (5) Remove the pin fixing the float and then remove the float.
- (6) Remove the cross recessed pan head machine screw (M4) (by using a cross slot screwdriver).
- (7) Remove the pin fixing the valve and then remove the valve and float.
- (8) Remove the valve guide (width across flat: 14 mm) and the hanger.

8. Exploded view

