

MODEL TA-22ML FLOAT VENT VALVE

PRODUCT MANUAL

Thank you very much for choosing the Yoshitake's product. To ensure the correct and safe use of the product, please read this manual before use. This manual shall be kept with care for future references. The symbols used in this manual have the following meanings.



	Warning	This symbol indicates a potentially hazardous situation that, if not avoided, could result in death or serious injury.
	Caution	This symbol indicates a hazardous situation that, if not avoided, may result in minor or moderate injury or may result in only property damage.

Table of Contents

1. Usage of the product	1
2. Specifications and Capacities	1
3. Dimensions and Weights	3
4. Operation	4
5. Maintenance and Inspection	5
5.1 Precaution before use	5
5.2 Precaution for use	6
5.3 Piping example	6
5.4 Troubleshooting	7
5.5 Precaution for maintenance	7
6. Exploded view	8

YOSHITAKE

1. Usage of the product

Float vent valve removes air inside piping and prevents decrease of heat efficiency, noise production or corrosion of equipment piping by commingling of air, etc.

TA-22ML float vent is compact float type, discharges air automatically without any manual operation.

2. Specifications and Capacities

Nominal size	15-25A	
Application	Cold and hot water	
Working pressure	0.01-1.0 MPa	
Maximum temperature	100°C	
Material	Body, cover	Bronze
	Disc	Synthetic rubber
	Float	High temperature resin
Connection	Inlet	JIS R screwed
	Outlet	Hose fitting (Φ6)
Coating	Nickel coating	



Caution

Please confirm that the indications on the product correspond with the specifications of the ordered product model before use.

* If they are different, do not use the product and contact us.

Exhaust capacity chart

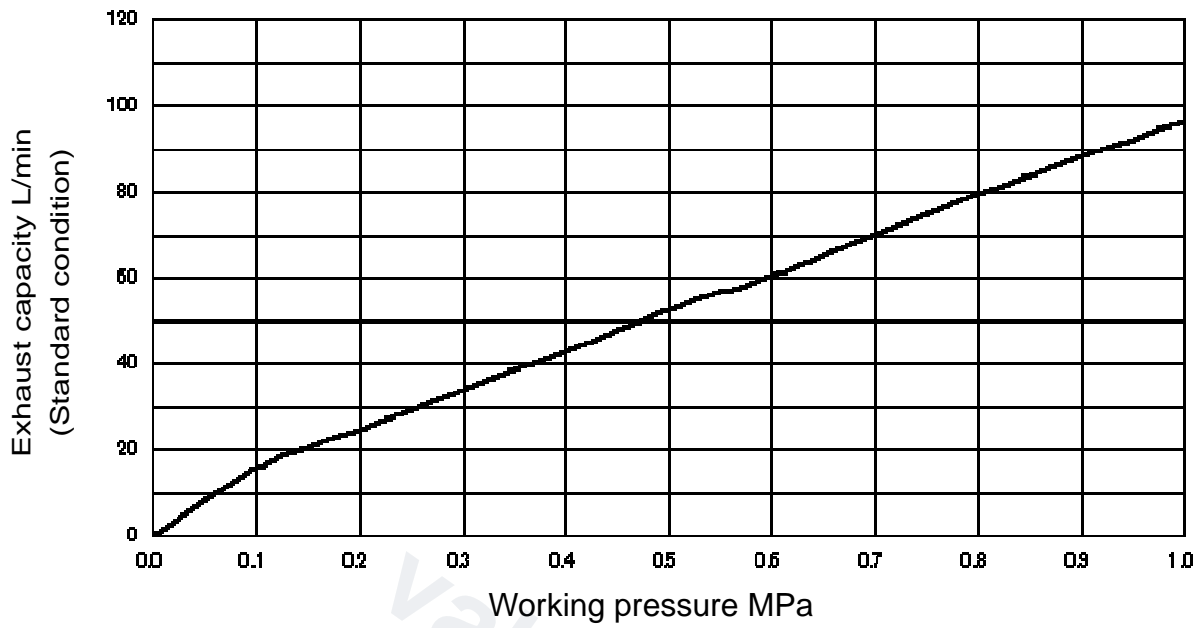

3. Dimensions and Weights

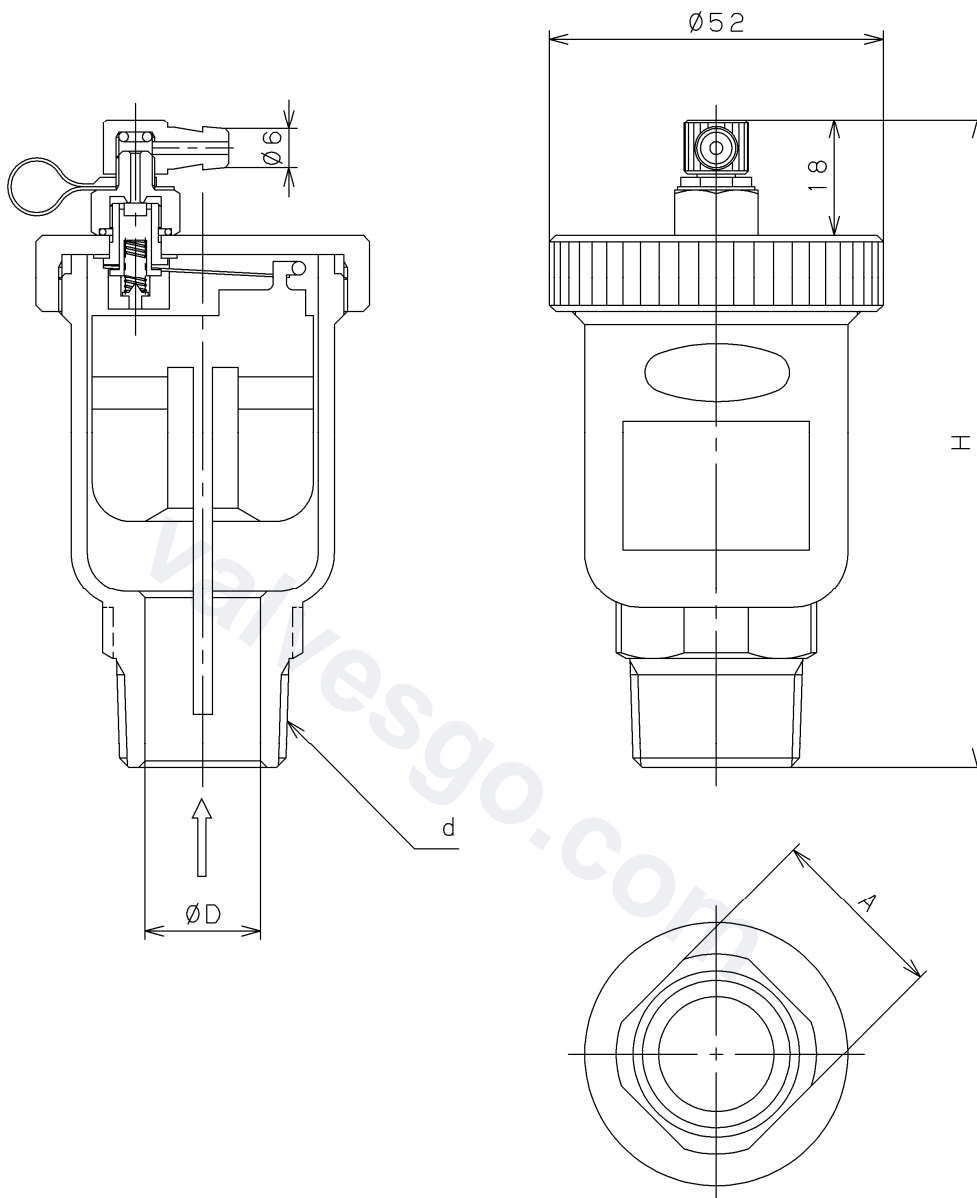

(mm)

Size	d	D	A	H	Weight (kg)
15A	R 1/2	13	23	95.5	0.36
20A	R 3/4	18	28	101	0.4
25A	R 1	23	35	104	0.46

4. Operation

1. After installation, air exists in the product, and float [11] is lowered by its own weight. In this condition, since valve [8] is kept open by lever [7], air is discharged outside by internal pressure of the system.
2. When air is discharged, hot or cold water flows into the product to make float [11] come up on buoyancy and force that keeps valve [8] open through lever [7] is lost. Then valve [8] is closed by spring [9] and pressure to valve [8].
3. When air bubbles are generated in the system and collected into the product, water level inside the product drops, and float loses buoyancy and opens valve [8] to discharge air.
4. Then the operation goes back to the above process 2. Repeating the processes 2 and 3, air in the system can be removed.

Structural view

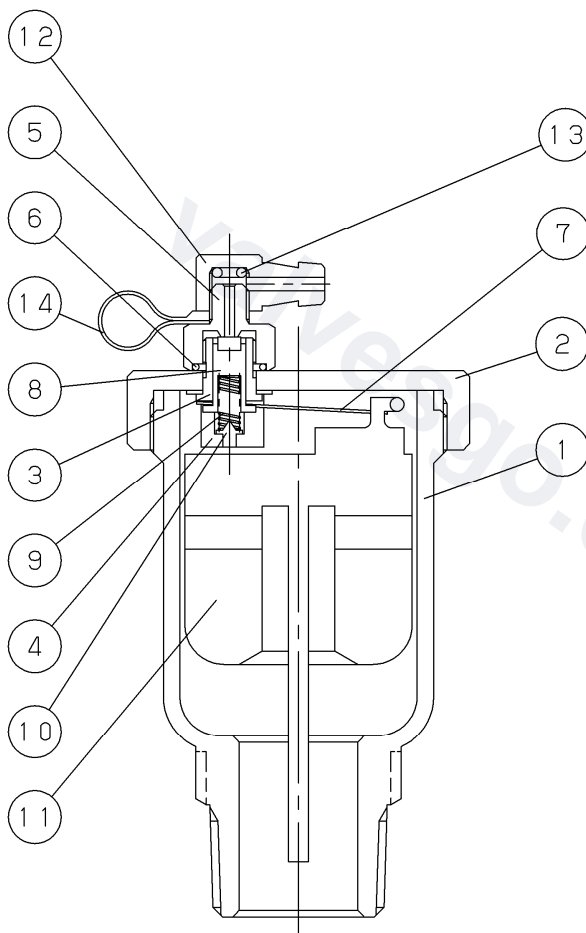

No.	Parts name
1	Body
2	Cover
3	Guide
4	Hanger metal
5	Valve seat
6	O ring
7	Lever
8	Valve
9	Spring
10	Spring tray
11	Float
12	Elbow cap
13	O ring
14	Stopper

5. Maintenance and inspection

5.1 Precaution before use

Caution

1. After tightening elbow cap, be sure to attach hose to the product, and lead it to drain ditch (see Fig. 1). In addition, after attaching hose, fix the hose to avoid loosening of elbow cap.
 - * When foreign substance such as dust adheres to valve with elbow cap loosened and valve leakage occurs, water may leak from around elbow cap to outside. Do not use the product for a place where other devices can get wet by water when water leakage occurs.
 - * Valve leakage may lead to contaminate surroundings, scald if fluid is high-temperature, or damage to body or property.

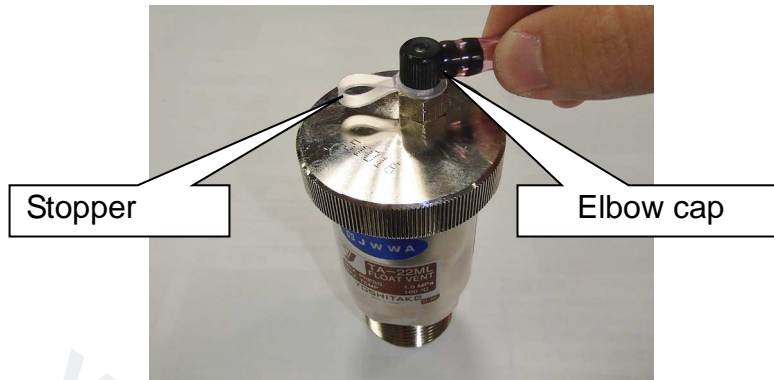
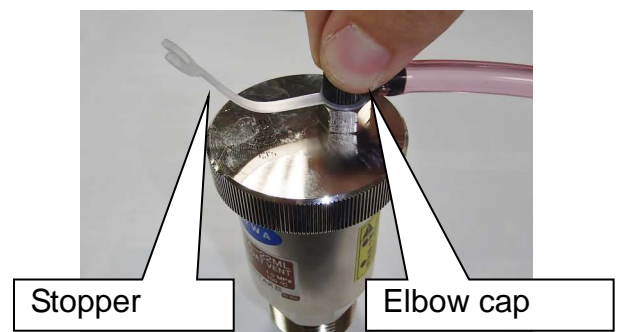

Fig. 1

2. Install the product to a place where confirmation and support can be conducted to tighten elbow cap when valve leakage occurs.
 - * Valve leakage may lead to contaminate surroundings, scald if fluid is high-temperature, or damage to body or property.
3. Install the product vertically to a place where air is easy to accumulate.
 - * Failure to follow this notice may prevent the product from functioning properly.
4. Before installing the product, be sure to remove foreign substances and scale from the piping.
 - * Commingling of foreign substance or scale into the product prevents the product from functioning properly.
5. To install the product to piping, tighten hexagonal part of the product with tools such as wrench. Avoid overtightening.
 - * Failure to follow this notice deforms body of the product or leads to prevent functioning properly.
6. Install the product to a place where maintenance and inspection can be conducted easily.
7. Install the product to a place cannot be applied to abnormal high pressure by water hammer, etc.
8. On test operation of water heater, conduct inspection for connection part of float vent, and check that there is no leakage.
9. When on operation foreign substance such as dust adheres to valve and valve leakage occurs, clean the valve (see 5.4 Troubleshooting). As an emergency treatment, remove the head of stopper and tighten elbow cap. Water leakage can be stopped (see Fig.2). Also, when tightening elbow cap, tighten it after removing hose. After tightening, clean the valve.



10. Since elbow cap is made of resin, it is treated as consumable supply.
11. For brass parts, corrosion is generated or accelerated by water quality, and leads to malfunction of the product. For surroundings where corrosion can be generated, please select the product with enduring parts such as stainless steel material.
12. If component having negative effect on inner parts is included in fluid and surroundings, deterioration of rubber parts is accelerated and causes outside leakage and functional disorder.
13. Keeping fluid in the product for a long term fixes sliding parts and leads to malfunction of the product
14. Performance value of Nominal Size Selection Chart is referential value. Since it can change according to piping condition and usage environment, secure safety factor of 20% or more for performance value when selection.
15. Do not make dissimilar metal piping which causes difference of electrical potential. If not, the product and parts are corroded.

5.2 Precaution for use



Warning

Do not touch the product with bare hands in case of high-temperature fluid.
* Failure to follow this notice may result in burns.



Caution

1. Do not use the product over working pressure range or over maximum working temperature.
*Failure to follow this notice damages the product or leads to air exhaust defect.
2. On test operation of water heater, conduct inspection for connection part of float vent, and check that there is no leakage.
3. When on operation foreign substance such as dust adheres to valve and valve leakage occurs, clean the valve (see 5.4 Troubleshooting).

5.3 Piping example

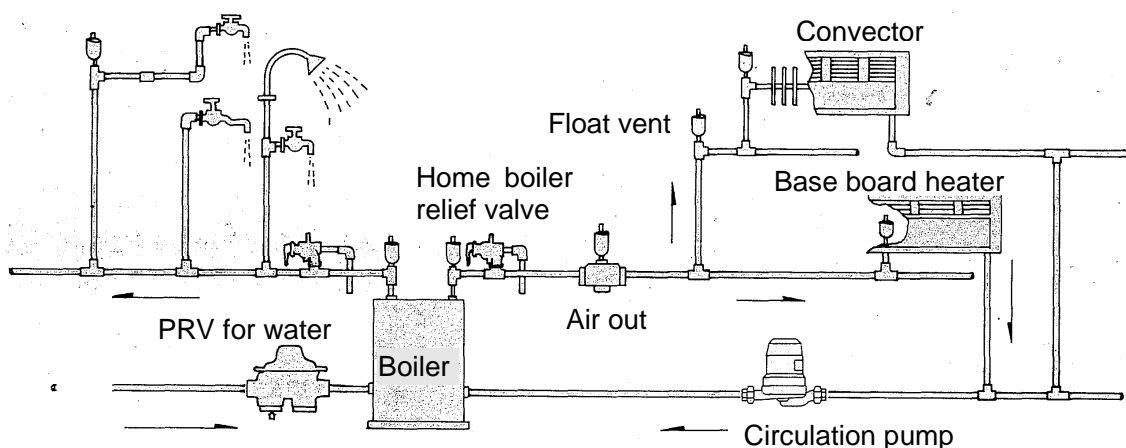



If using the product with AO-2 air out (air separator), higher performance can be obtained.

5.4 Troubleshooting

Trouble	Cause	Remedy
Water leakage occurs	1. Foreign substance such as dust adheres to valve and valve seat.	1. By removing valve seat part with spanner, seal surface of valve and valve seat can be cleaned. Clean off scale and dust adhering to valve and valve seat with waste cloth, and after cleaning, apply O ring (S9) to ditch of valve seat and screw it, then tighten it with spanner.
Air is not discharged	1. Air accumulation is bad.	1. Install the product to a place where air is easy to accumulate.
	2. Pressure inside piping is more than appropriate pressure.	2. Decrease pressure inside piping. Or, replace with piping for high pressure.

5.5 Precaution for maintenance

 Warning	<p>Completely discharge internal pressure of the product, piping and equipment. Cool down the product prior to disassembling or maintenance in case of high-temperature fluid.</p> <p>*Failure to follow this notice may result in scalds or bodily injury due to residual pressure.</p>
--	--

 Caution
<ol style="list-style-type: none"> 1. Conduct daily inspection and regular inspection to maintain function and performance of the product. * If defect is found, ask professionals. 2. Disassembly and inspection shall be performed by an experienced professional or valve manufacturer. 3. When the product is not used for an extended period, conduct operational check before operation. * If defect is found, ask professionals.

1. Stop driving of heat source (hot water boiler, electrical water heater, etc) and pump.
2. Remove pressure inside piping.
3. Remove valve seat with spanner (nominal size: 12mm) (see Fig.3).
4. By removing valve seat, seal surface of valve and valve seat can be cleaned. Clean off scale and dust adhering to valve and valve seat with waste cloth. (see Fig. 4)

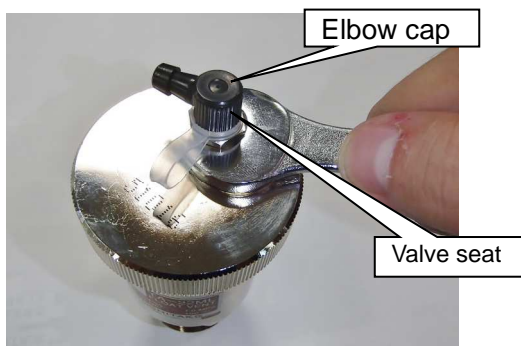

Fig.3

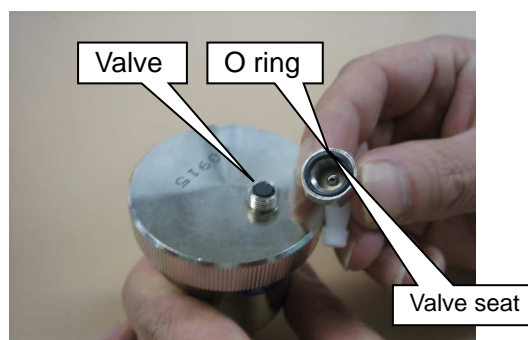

Fig. 4

5. After cleaning, apply O ring (S9) to ditch of valve seat and screw it, then tighten it with spanner. O ring and elbow cap are treated as consumable supply (Tightening torque: approximately 3 N·m).

6. Exploded View

*Elbow cap is made of resin, it is treated as consumable supply.

