



# ***TRAP STAR***<sup>TM</sup> **MODEL TSF-12** **STEAM TRAP**

## **PRODUCT MANUAL**

Thank you very much for choosing the Yoshitake's product. To ensure the correct and safe use of the product, please read this manual before use. This manual shall be kept with care for future references.

The symbols used in this manual have the following meanings.

 <b>Warning</b>	This symbol indicates a potentially hazardous situation that, if not avoided, could result in death or serious injury.
 <b>Caution</b>	This symbol indicates a hazardous situation that, if not avoided, may result in minor or moderate injury or may result in only property damage.

---

### **Table of Contents**

---

1. Specifications.....	1
2. Operation .....	1
3. Maximum Continuous Discharge Capacity .....	2
4. Installation	
4.1 Piping example .....	3-4
4.2 Precaution for installation.....	5-6
5. Operating Procedure	
5.1 Precaution for operating procedure .....	6
6. Maintenance	
6.1 Precaution for maintenance .....	6-7
6.2 Daily and periodic inspections .....	7
6.3 Troubleshooting.....	7-8
6.4 Exploded drawing .....	8
6.5 Disassembly .....	9-10
6.6 Reassembly.....	10-13
6.7 Parts replacement procedure .....	13
Warranty Information	

# **YOSHITAKE**

## 1. Specifications

Model		TSF-12
Nominal size		40A,50A
Application		Steam condensate
Working pressure (Maximum working differential pressure)		TSF-12-1 : 0.01-0.1 MPa (0.1 MPa) TSF-12-2 : 0.01-0.2 MPa (0.2 MPa) TSF-12-5 : 0.01-0.5 MPa (0.5 MPa) TSF-12-9 : 0.01-0.9 MPa (0.9 MPa) TSF-12-12 : 0.01-1.2MPa (1.2 MPa) TSF-12-17 : 0.01-1.7MPa (1.7 MPa)
Max. temperature		230°C
Material	Body	Ductile cast iron
	Float	Stainless steel
	Valve, valve seat	Stainless steel
Connection		JIS Rc screwed NPT screwed

\* For installation posture, see 3 of "5.2 Precaution for installation" .



### Caution

1. Depending on application, specification of the product shall be selected. Refer to Technical material, e.g. Operating instruction, Technical guidebook, and drawing, and select suitable specification. Regarding technical material like drawing, contact our sales office.
2. Please confirm that the indications on the product correspond with the specifications of the ordered product model before use.  
\* If they are different, do not use the product and contact us.

## 2. Operation

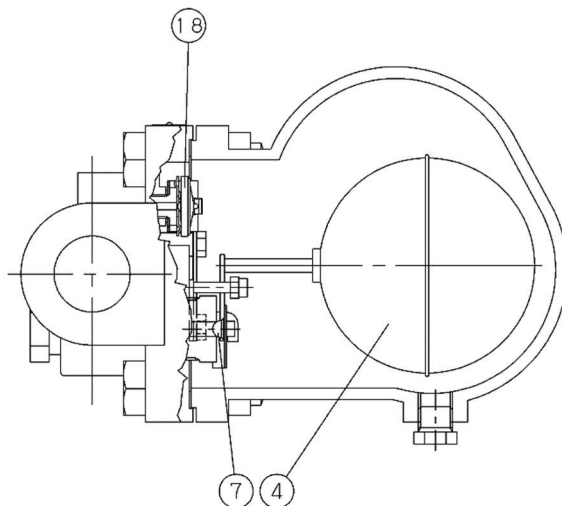

At start-up, since the float④ is down, the valve⑦ is closed. In this state, air in the system and piping is discharged out through the air vent⑱ which is opened. When condensate flows into the product, the float④ lifts up and opens the valve⑦, and then discharges condensate. Air is continuously discharged out from the air vent⑱. When steam flows into the product, internal pressure of the air vent⑱ rises by steam temperature, and the air vent⑱ closes. According to the amount of condensate inflow, the float④ position moves up and down changing the opening degree of the valve⑦, and thus condensate is continuously discharged.

### 3. Maximum Continuous Discharge Capacity

1. Discharging capacity of the steam trap differs by working differential pressure, that is, difference between inlet pressure and outlet pressure (back pressure). In selecting discharge capacity, consider outlet pressure. If inlet pressure is 0.5 MPa and outlet pressure is 0.2 MPa, discharge capacity is of working differential pressure of 0.3 MPa.
2. The discharge capacity shown in the charts below is the maximum value. In designing a system, select a steam trap with a sufficient safety factor (at least twice). That is, for example, if a discharge capacity of 1000 kg/h is required, select a steam trap capable of discharging more than 2000 kg/h (maximum discharge).

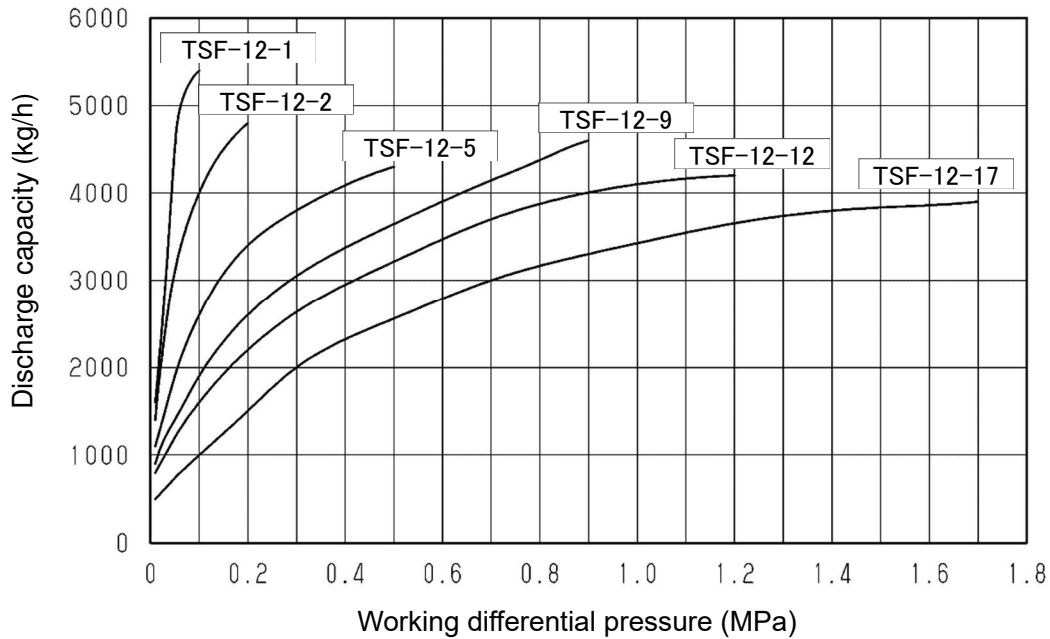

#### Maximum Continuous Discharge Capacity of TSF-12 40A

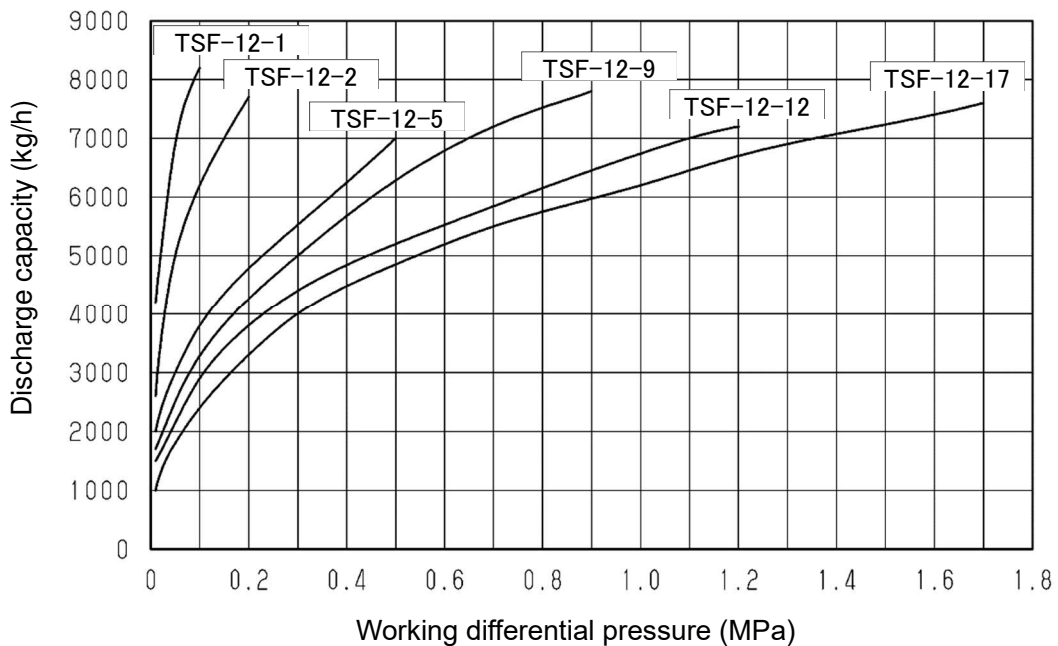

#### Maximum Continuous Discharge Capacity of TSF-12 50A

## 4. Installation

### 4.1 Piping example

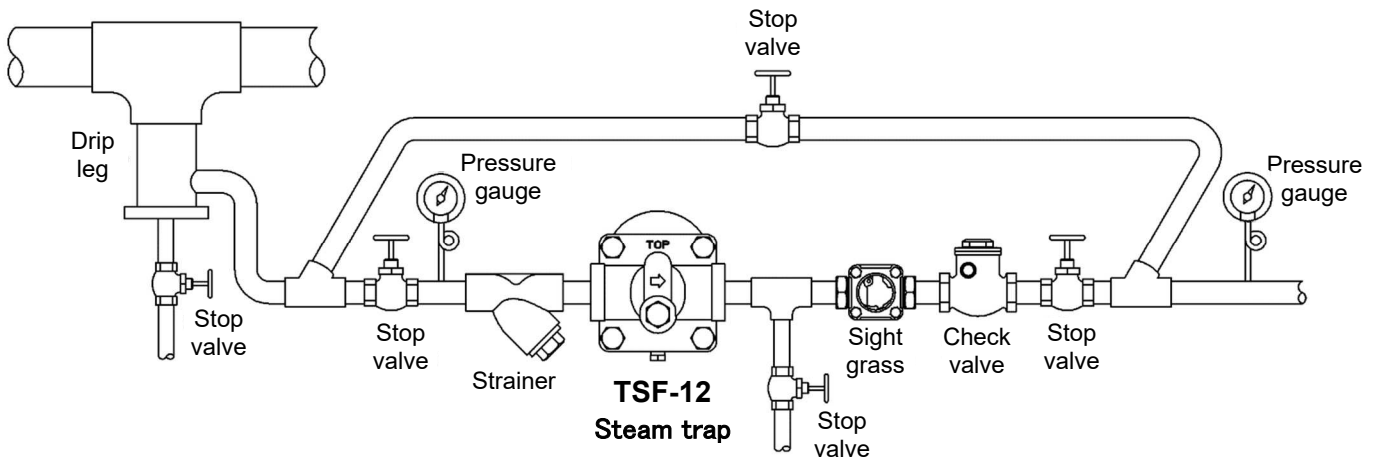

Description	Correct	Incorrect
<p>If the product is installed close to a regulating valve, make sure to install the product at the inlet side of the regulating valve.</p>	<p style="text-align: center;">Regulating valve</p>	<p style="text-align: center;">Regulating valve</p>
<p>To discharge condensate from the steam main, be sure to install the product on piping taken from the lower part of drip leg.</p>	<p style="text-align: center;">Steam main</p> <p style="text-align: center;">Drip leg</p> <p style="text-align: center;">Stop valve</p> <p style="text-align: center;">Trap</p>	<p style="text-align: center;">Steam main</p> <p style="text-align: center;">Trap</p>
<p>Install the product below a device which generates condensate.</p>		

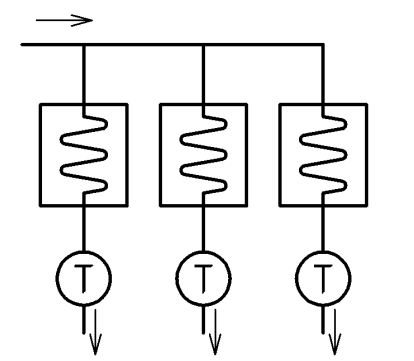
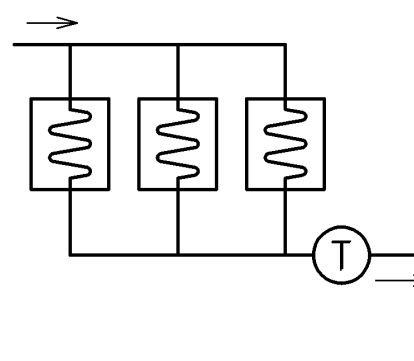
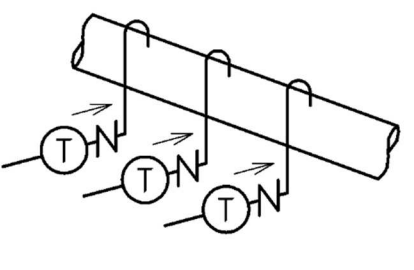
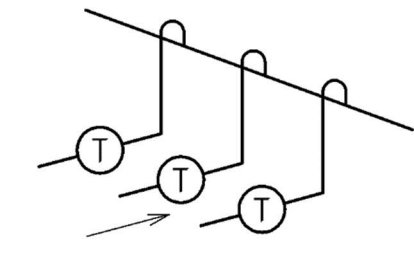
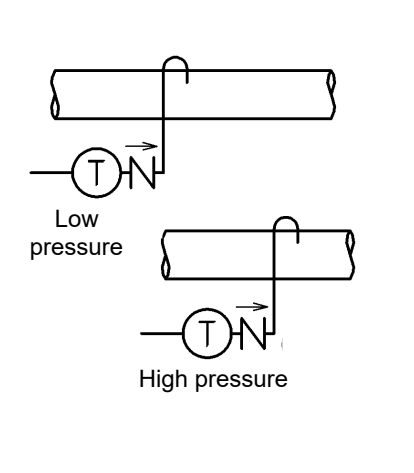
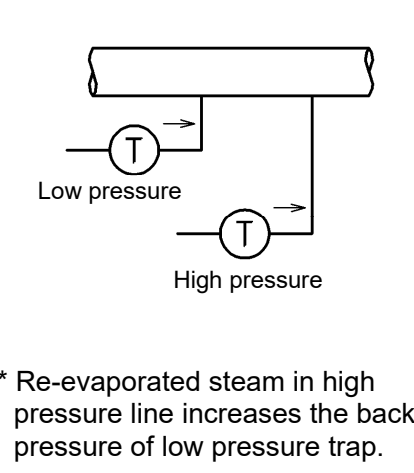
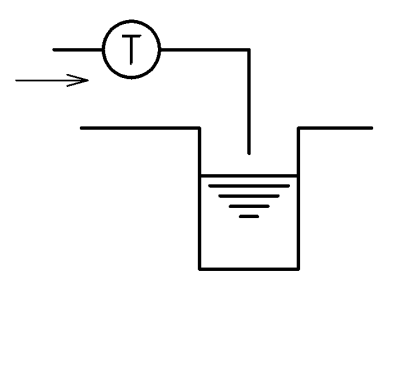
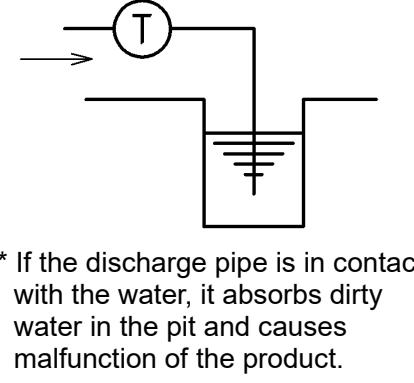
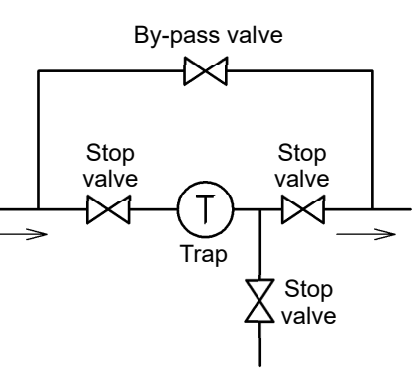
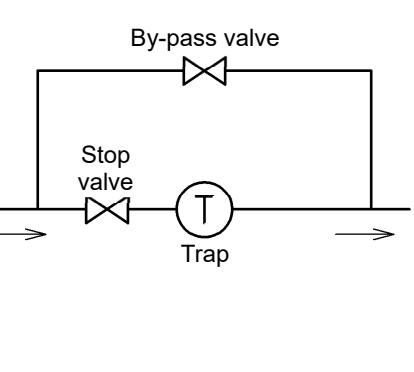
Description	Correct	Incorrect
<p>Install the products for each device independently.</p>		
<p>The diameter of collecting pipe shall be more than summation of sectional areas of discharge pipes. In addition, install check valves for back flow prevention.</p>		
<p>For condensate recovery, connect the discharge pipe to the upper part of collecting pipe. For traps of different pressure lines, install collecting pipes individually for each pressure. In addition, install check valves for back flow prevention.</p>		
<p>End portion of discharge pipe shall be off the water surface in the pit.</p>		
<p>Provide a by-pass line around the product, and install stop valves at the outlet side of the product.</p>		

## 4.2 Precaution for installation

### Warning

1. In order to discharge condensate to the atmosphere, lead the outlet to a safe place where there is no possibility of physical damage even if condensate blows out.
  - \* There are risks of scalding or injury when the condensate blows out.

### Caution

1. Before connecting the product to piping, remove foreign substances and scale from the piping.
  - \* Failure to follow this notice may prevent the product from functioning properly.
  - \* To plumb the product, be careful to keep seal materials from entering into the product.
2. To install the product, check the direction of the product so that the fluid flowing and the arrow mark on the product are in the same direction.
  - \* Setting the product in wrong directions prevents it from functioning properly.
3. **Check installation posture. Do not tilt the product during use.**
  - \* Wrong posture hampers proper operation.

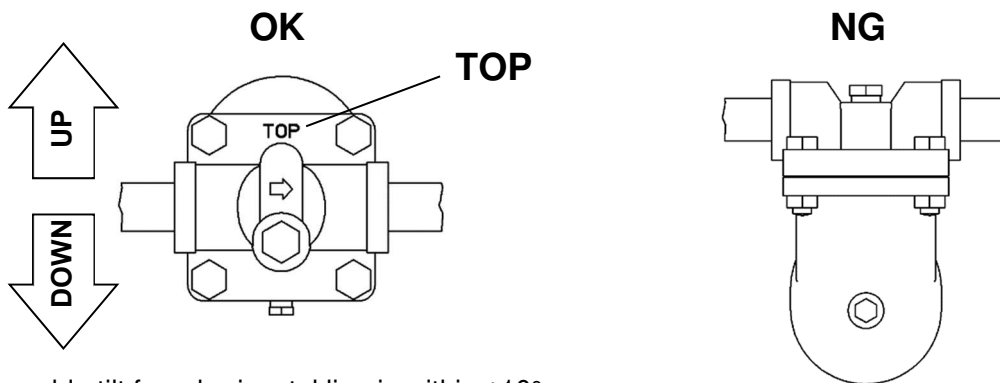

- \* Allowable tilt from horizontal line is within  $\pm 10^\circ$ .
- \* Support the product cover when it is necessary.

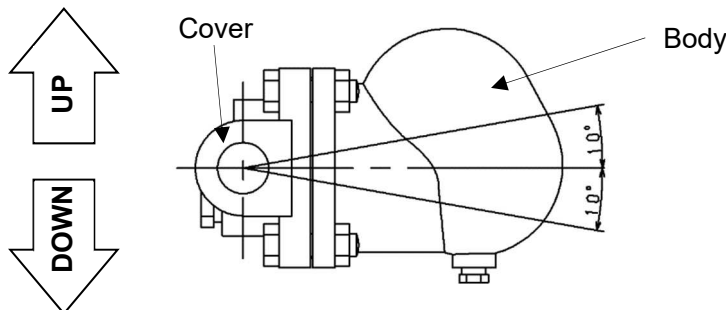

4. Make sure to support the piping immovably.
  - \* If an excessive piping stress is applied, there are cases when the product will not open or close.
5. Do not disassemble the product unless it is necessary.
  - \* Unnecessary disassembly may prevent the product from functioning properly.
6. Secure enough space for maintenance, inspections and repair as shown below.
  - \* Failure to follow this notice prevents maintenance, inspection and repair.

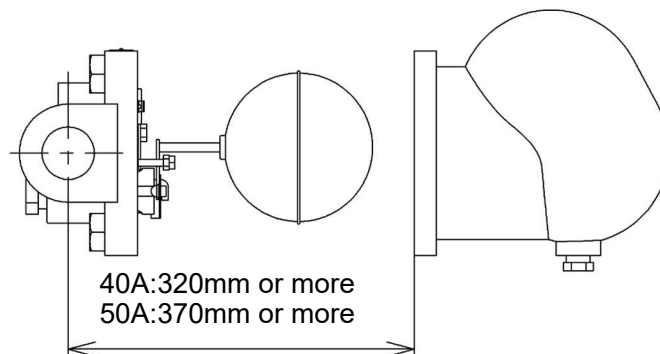

7. Slope the piping and place the product at as a low position as possible in order to make condensate flow into the product by its own weight.
8. To install the product in a main steam pipe, provide a drip leg at the inlet side of the product.
9. Install a strainer (mesh size of 80 or more is recommended) at the inlet side of the product.
10. Install the product in a way it is not subjected to the shock of water hammer. Do not install a quick operating valve before and/or after the product.
  - \* Failure to follow this notice may result in malfunction due to damage to the float or air vent, or may result in scalds or injury due to blow off when the product is subjected to an excessive shock and damaged.
11. Install a bypass line.
  - \* The system has to stop operation while inspection and maintenance of the product if the bypass line is not installed.

---

## 5. Operating Procedure

---

### 5.1 Precaution for operating procedure

#### **Warning**

1. Before leading fluid, make sure that the product is securely connected to piping and that there is no loose.
  - \* There are risks of scalding or injury when the steam or condensate blows out.
2. Do not touch the product with bare hands while the product operates.
  - \* There are risks of scalding.
3. Do not stand in front of the outlet opening of the product while the product operates.
  - \* There are risks of scalding or injury due to blow off.

#### **Caution**

1. Slowly open each stop valve to prevent water hammer.
  - \* When opening stop valves quickly, there are cases when the equipment will be damaged due to hunting or water hammer.

---

## 6. Maintenance

---

### 6.1 Precaution for maintenance

#### **Warning**

1. Do not touch the product with bare hands.
  - \* There are risks of scalding.
2. Completely discharge internal pressure of the product, piping and equipment, and cool down the product prior to disassembly or maintenance.
  - \* There are risks of scalding or injury due to residual pressure.

#### **Caution**

1. Conduct daily inspection in order to maintain the optimal performance of the product.
  - \* Failure to follow this notice may prevent the product from functioning properly.
  - \* See "7.3 Troubleshooting" on Page 8 and 9 if trouble is observed.
2. After leaving the product not operated for a long period, perform inspection before start-up of operation.
  - \* Failure to follow this notice may cause malfunction due to rust inside of the product and piping.
3. Put a container under the product at disassembly since condensate may flow out.
  - \* Failure to follow this notice may result in making the surroundings dirty.
4. Be careful not to drop the parts at the time of disassembly. The disassembled parts should be placed on soft cloth in order to avoid scratches and damage.
  - \* Damage on the parts may cause malfunction and affect the optimal performance.

 **Caution**

5. To assemble, connect all the parts securely and tighten the bolts uniformly in diagonal order.  
\* Failure to follow this notice may cause malfunction or outside leakage.
6. When repairing, do not use the parts other than the dedicated parts manufactured by Yoshitake. Do not modify the product.  
\* Failure to follow this notice may cause damage to the product, or may result in scalds or injury due to blow-off or malfunction.
7. In case of problems due to foreign substances or scale, the product needs repair or part replacement. Please contact us for details.  
(Please note that any repair due to foreign substances or scale in the product is subject to a charge even during the warranty period.)

## 6.2 Daily and periodic inspections

Conduct daily and periodic inspections in order to maintain the optimal performance of the product. See "7.3 Troubleshooting" on Page 8 and 9 for the remedies if trouble is observed.

- Daily inspection (once a day)

Conduct daily inspection during operation of the product.

Items	Standards for Inspection
Discharge condition of condensate	Condensate is discharged smoothly.
Outside leakage	No outside leakage of condensate or steam.

- Periodic inspection (once a year)

Conduct disassembly inspection periodically.

Items	Standards for Inspection
Seat surfaces of the valve and valve seat	No scratch, abrasion, or foreign substances on seat surfaces.
Shape of float (P)	No deformation or damage on the float (P)

## 6.3 Troubleshooting

Trouble	Cause	Remedy
Condensate is not discharged.	1. Blockage of foreign substances in the valve seat.	1. Disassemble and clean it.
	2. Float (P) is broken	2. Change it into new one.
	3. Breakage as a result of abnormal pressure rising due to freezing or water hammer, etc.	3. Replace the product with new one.
	4. Steam locking.	4. Change the piping system layout.
	5. Product is in wrong posture.	5. Adjust direction of the mark "TOP" to upward. *See Caution No. 3, "5.2 Precaution for Installation" on Page 6.

Trouble	Cause	Remedy
Continuous blowout.	1. Foreign substances stuck on valve, valve seat or air vent (P).	1. Disassemble and clean them.
	2. Abrasion or scratches on the valve, valve seat, air vent (P) or air vent valve seat.	2. Replace the parts.
	3. Insufficient capacity of the product.	3. Replace the product with another model of sufficient capacity.
	4. Product is in wrong position.	4. Adjust direction of the mark "TOP" to upward. *See Caution No. 3, "5.2 Precaution for Installation" on Page 6.
Steam leakage.	1. Leakage due to loosening of the bolt.	1. Replace the cover gasket with new one, and retighten the bolt. *See Procedure 6, "7.6 Reassembly" on Page 14.
	2. Leakage as a result of abnormal pressure rising due to freezing or water hammer, etc.	2. Replace the product with new one.

#### 6.4 Exploded drawing

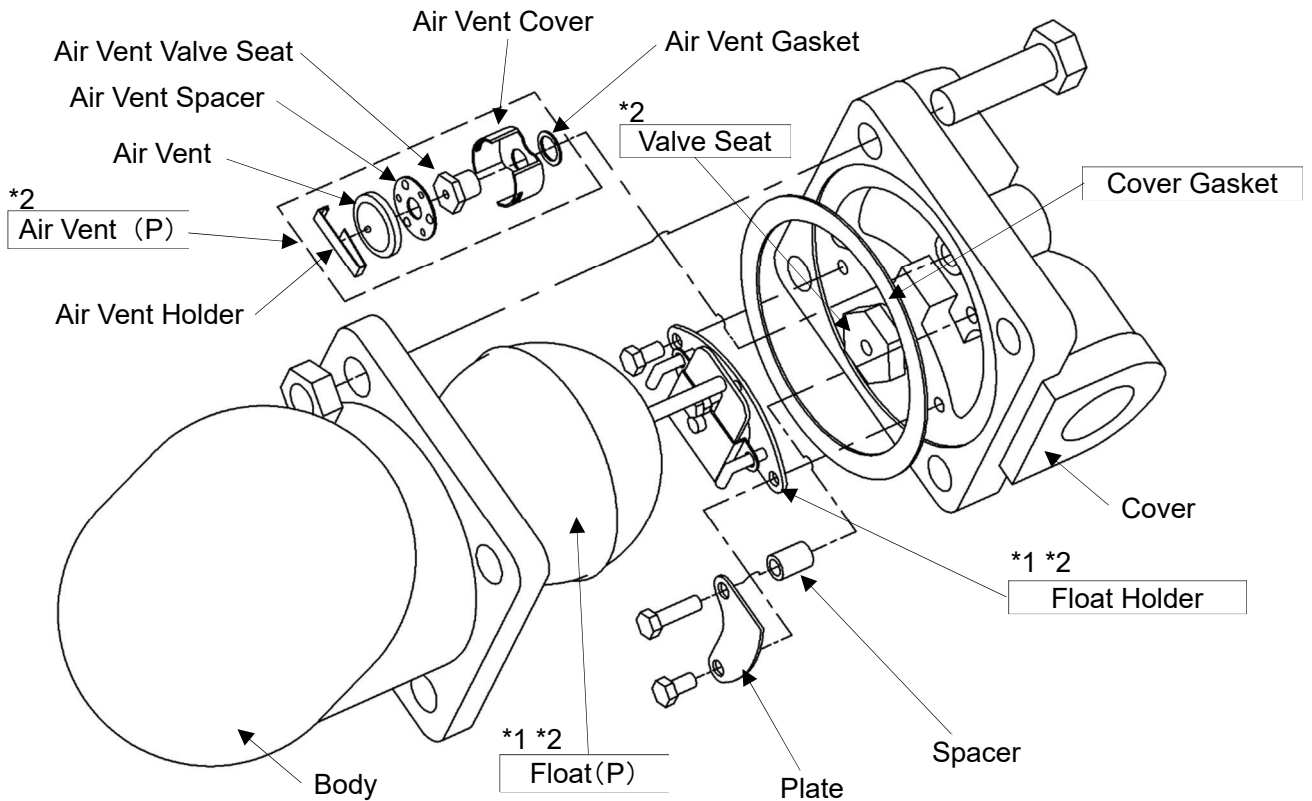

\* The parts shown in the rectangle boxes are available as consumable supply.  
 \*1 [Float (P) and float holder] can be removed together (can not be disassembled).  
 \*2 are available as set parts.

## 6.5 Disassembly

- Tools to be used

Name of tool	Size (Nominal size)
Spanner, Ring wrench	13 , 32 mm
Socket wrench	19 , 39 mm
Radio pliers	

[Procedure 1] Remove the hexagon bolts and nuts that fixing the body with a spanner, wrench, etc (width across flat: 32mm). Then remove the body and gasket from the cover.

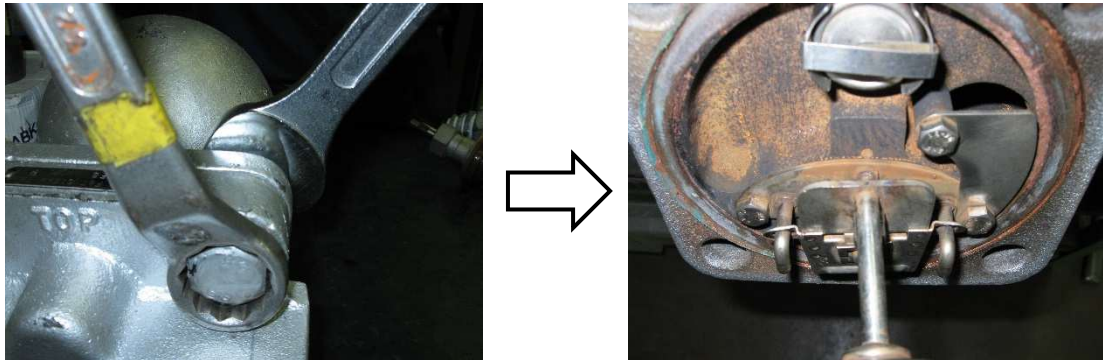

[Procedure 2] Remove the air vent holder with radio pliers.

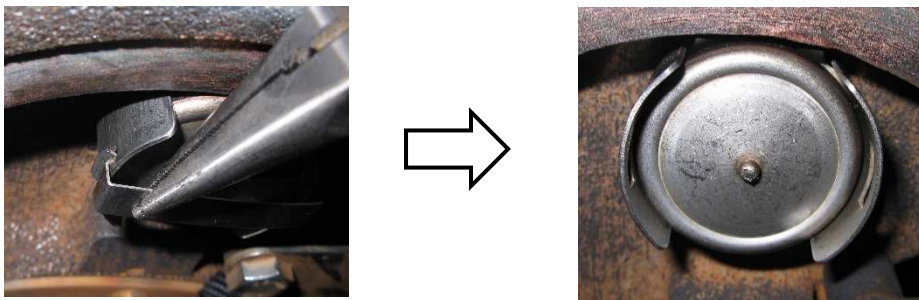

[Procedure 3] Remove air vent and spacer by hand.



[Procedure 4] Remove the air vent valve seat with socket wrench (width across flat: 19 mm). Be careful as the valve seat has a gasket.

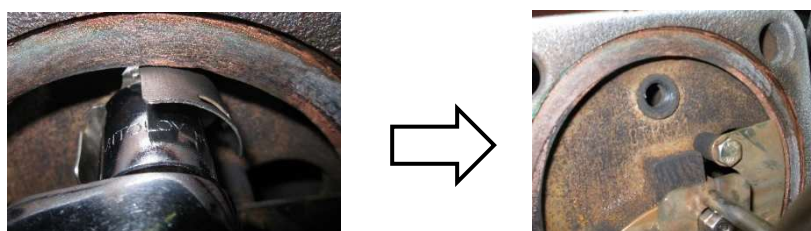

[Procedure 5] Remove the hexagon bolt on the upper side of the plate and the bolt on the inlet side of the float holder with spanner, ring wrench, etc (width across flat: 13mm). Then remove the plate.

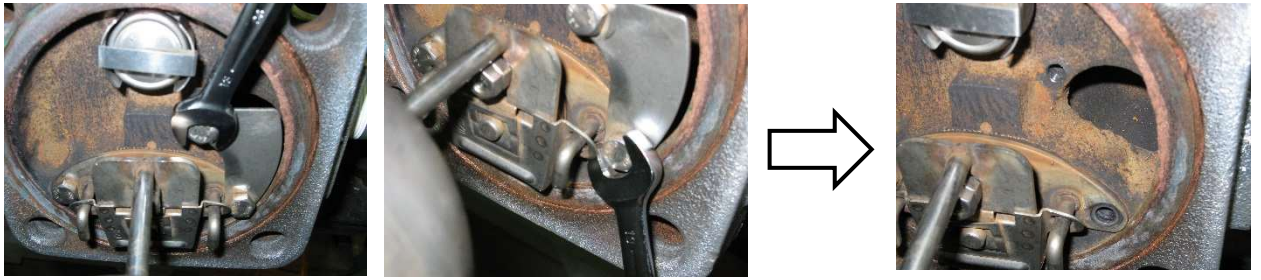

[Procedure 6] Remove the hexagon bolt on the outlet side of the float holder with spanner, ring wrench, etc (width across flat: 13mm). Then the float (P) and float holder can be removed. The valve is attached to the float (P).



[Procedure 7] Remove the valve seat with socket wrench (width across flat: 39 mm).

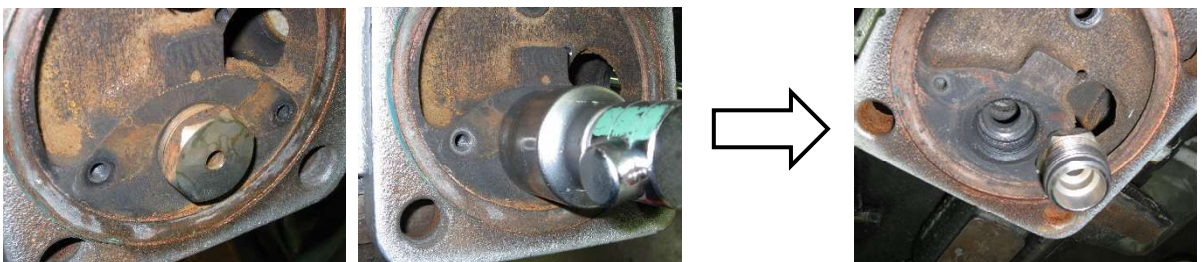

## 6.6 Reassembly

- Tools to be used

Name of tool	Size (Nominal size)
Torque Wrench	* Tightenable with torque of 200 N·m Width across flat: 32 mm
Torque Wrench	* Tightenable with torque of 30 N·m, Open-head type Width across flat: 13 mm
Torque Wrench	* Tightenable with torque of 50 N·m Width across flat: 19 mm
Torque Wrench	* Tightenable with torque of 230 N·m Width across flat: 39 mm
Spanner, Ring wrench	13 mm
Radio pliers	

[Procedure 1] Tighten the valve seat with a torque of 230 N·m using torque wrench(width across flat: 39 mm).



[Procedure 2] Assemble the air vent valve seat, air vent cover and air vent gasket, and attach them to the cover by tightening with 50 N·m torque using torque wrench (width across flat: 19 mm). At that time, adjust the air vent cover to make its rectangular holes come on both sides (not top and down), as shown in the picture.

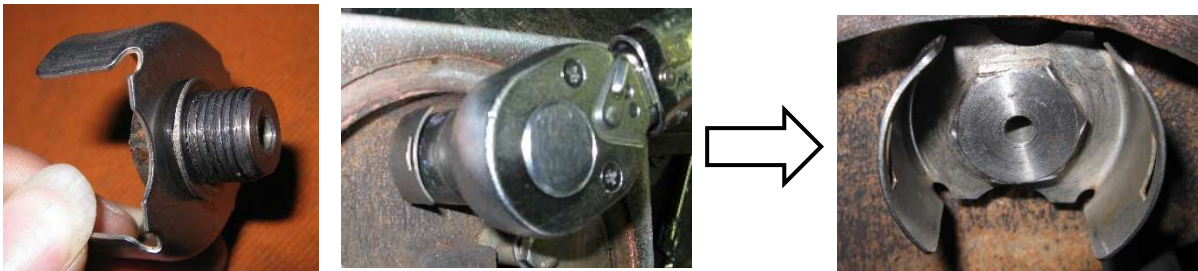

[Procedure 3] Put the spacer and attach the air vent in the air vent cover. Please pay attention to the direction of the air vent.



[Procedure 4] Air vent holder can be assembled by hand.

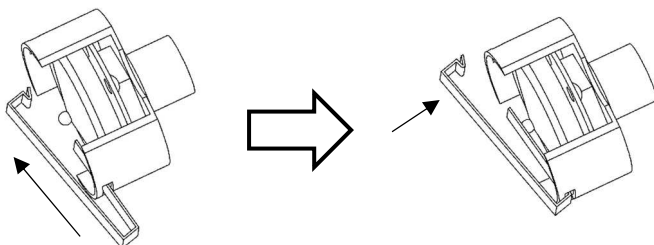

Assembled Air vent(P)

[Procedure 5] Temporarily tighten the hexagon bolt at the outlet side of the float holder with a spanner, ring wrench, etc (width across flat: 13 mm).



Next, align the screw hole on the inlet side of the float holder and the bottom hole of the plate, and temporarily tighten the hexagon bolt with a spanner, ring wrench, etc (width across flat: 13 mm). The plate will be on the upper side of the float holder as shown in the picture.



Then, align the spacer with the plate top hole and temporarily tighten the bolt.



After temporarily tightening the three bolts, tighten them with torque of 30 N·m with a torque wrench (width across flat: 13 mm).

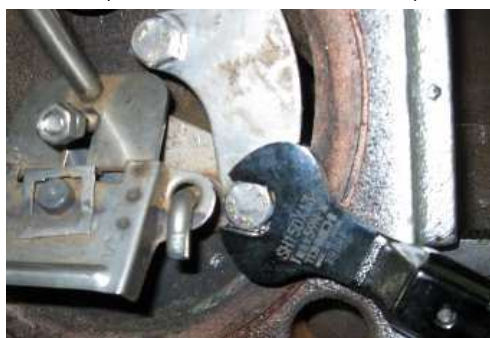

[Procedure 6] Put a new gasket on the cover and tighten the hexagon bolts and nuts fixing the body with 200 N·m torque using torque wrench (width across flat: 32 mm).



## 6.7 Parts replacement procedure

Part name	Disassembly (See 7.5.)	Reassembly (See 7.6.)
Cover gasket	Procedure 1	Procedures 6
Float (P) Float Holder Assembly	Procedures 1 & 5 to 6	Procedures 5 to 6
Valve Seat	Procedures 1 & 5 to 7	Procedures 1 & 5 to 6
Air vent (P) ※	Procedures 1 to 4	Procedures 2 to 4 & 6

※Air vent(P) refers to air vent holder, air vent, air vent spacer, air vent valve seat, air vent cover and air vent gasket.

---

## Warranty Information

---

1. Limited warranty

This product has been manufactured using highly-advanced techniques and subjected to strict quality control. Please be sure to use the product in accordance with instructions on the manual and the label attached to it.

Yoshitake warrants the product to be free from any defects in material and workmanship under normal usage for a period of one year from the date of receipt by the original user, but no longer than 24 months from the date of shipment from Yoshitake's factory.

2. Parts supply after product discontinuation

This product may be subject to discontinuation or change for improvement without any prior notice. After the discontinuation of the product, Yoshitake supplies the repair parts for 5 years otherwise individually agreed.

3. This warranty does not cover the damage due to any of below:

- (1) Valve seat leakage or malfunction caused by foreign substances inside piping.
- (2) Improper handling or misuse.
- (3) Improper supply conditions such as abnormal water pressure/quality.
- (4) Water scale or freezing.
- (5) Trouble with power/air supply.
- (6) Any alteration made by other than Yoshitake.
- (7) Use under severe conditions deviating from the design specifications (e.g. in case of corrosion due to outdoor use).
- (8) Fire, flood, earthquake, thunder and other natural disasters.
- (9) Consumable parts such as O-ring, gasket, diaphragm and etc.

Yoshitake is not liable for any damage or loss caused by malfunction or defect of the product.